



PRELIMINARY

**S6E2G26H0A, S6E2G28H0A
S6E2G26J0A, S6E2G28J0A
S6E2G26HHA, S6E2G28HHA
S6E2G26JHA, S6E2G28JHA**

32-bit ARM[®] Cortex[®]-M4F FM4 Microcontroller

Devices in the S6E2G2 Series are highly integrated 32-bit microcontrollers with high performance and competitive cost. This series is based on the ARM Cortex-M4F processor with on-chip flash memory and SRAM. The series has peripherals such as motor control timers, A/D converters, and communications interfaces (USB, UART, CSIO (SPI), I²C, LIN). The products that are described in this data sheet are placed into TYPE5-M4 product categories FM4 Family Peripheral Manual Main Part (MN709-00001).

Features

32-bit ARM Cortex-M4F Core

- Processor version: r0p1
- Up to 180 MHz frequency operation
- FPU built-in
- Support DSP instructions
- Memory protection unit (MPU): improves the reliability of an embedded system
- Integrated nested vectored interrupt controller (NVIC): 1 NMI (non-maskable interrupt) and 128 peripheral interrupts and 16 priority levels
- 24-bit system timer (Sys Tick): system timer for OS task management

On-chip Memories

■ Flash memory

This series is on-chip flash memories.

- Up to 1024 Kbytes
- Built-in flash accelerator system with 16 Kbytes trace buffer memory
- Read access to flash memory that can be achieved without wait-cycle up to an operating frequency of 72 MHz. Even at the operating frequency more than 72 MHz, an equivalent single cycle access to flash memory can be obtained by the flash accelerator system.
- Security function for code protection

■ SRAM

This is composed of three independent SRAMs (SRAM0, SRAM1 and SRAM2). SRAM0 is connected to the I-code bus and D-code bus of Cortex-M4F core. SRAM1 and SRAM2 are connected to system bus of Cortex-M4F core.

- SRAM0: up to 128 Kbytes
- SRAM1: 32 Kbytes
- SRAM2: 32 Kbytes

External Bus Interface

- Supports SRAM, NOR, NAND flash and SDRAM device
- Up to 9 chip selects CS0 to CS8 (CS8 is only for SDRAM)
- 8-/16-/32-bit data width
- Up to 25-bit address bus
- Supports address/data multiplexing

- Supports external RDY function

■ Supports scramble function

- Possible to set the validity/invalidity of the scramble function for the external areas 0x6000_0000 to 0xDFFF_FFFF in 4 Mbytes units.
- Possible to set two kinds of the scramble key
- **Note:** It is necessary to use the Cypress provided software library to use the scramble function.

USB Interface (Max two channels)

The USB interface is composed of a Device and a Host.

■ USB Device

- USB 2.0 Full-speed supported
- Max 6 EndPoint supported
 - EndPoint 0 is control transfer
 - EndPoint 1, 2 can be selected bulk-transfer, interrupt-transfer or isochronous-transfer
 - EndPoint 3 to 5 can select bulk-transfer or interrupt-transfer
 - EndPoint 1 to 5 comprise double buffer
 - The size of each endpoint is as follows.
 - Endpoint 0, 2 to 5: 64 byte
 - EndPoint 1: 256 byte

■ USB Host

- USB2.0 Full-Speed/Low-Speed supported
- Bulk-transfer, interrupt-transfer, and isochronous-transfer support
- USB Device connected/dis-connected automatically detect
- IN/OUT token handshake packet automatically
- Max 256-byte packet length supported
- Wake-up function supported

Multi-function Serial Interface (Max 10 Channels)

- Separate 64 byte receive and transmit FIFO buffers for channels 1 and channels 4 to 7.
- Operation mode is selectable for each channel from the following:
 - UART
 - CSIO (SPI)
 - LIN
 - I²C
- UART
 - Full-duplex double buffer
 - Selection with or without parity supported

- Built-in dedicated baud rate generator
- External clock available as a serial clock
- Various error detect functions available (parity errors, framing errors, and overrun errors)

■ CSIO (SPI)

- Full-duplex double buffer
- Built-in dedicated baud rate generator
- Overrun error detect function available
- Serial chip select function (ch 6 and ch 7 only)
- Supports high-speed SPI (ch 4 and ch 6 only)
- Data length 5 to 16-bit

■ LIN

- LIN protocol Rev.2.1 supported
- Full-duplex double buffer
- Master/slave mode supported
- LIN break field generation (can change to 13- to 16-bit length)
- LIN break delimiter generation (can change to 1- to 4-bit length)
- Various error detect functions available (parity errors, framing errors, and overrun errors)

■ I²C

- Standard mode (Max 100 kbps)/Fast mode (Max 400 kbps) supported
- Fast mode Plus (Fm+) (Max 1000 kbps, only for ch 3 = ch A and ch 7 = ch B) supported

■ I²S

- Using CSIO (SPI) (ch 1 only) and I2S clock generator
- Supports two transfer protocol
 - I²S
 - MSB-justified
- Master mode only

DMA Controller (Eight Channels)

DMA controller has an independent bus, so the CPU and DMA controller can process simultaneously.

- Eight independently configured and operated channels
- Transfer can be started by software or request from the built-in peripherals
- Transfer address area: 32-bit (4 GB)
- Transfer mode: Block transfer/Burst transfer/Demand transfer
- Transfer data type: bytes/half-word/word
- Transfer block count: 1 to 16
- Number of transfers: 1 to 65536

DSTC (Descriptor System Data Transfer Controller; 256 channels)

The DSTC can transfer data at high-speed without going via the CPU. The DSTC adopts the descriptor system and, following the specified contents of the descriptor that has already been constructed on the memory, can access directly the memory/peripheral device and perform the data-transfer operation.

It supports the software activation, the hardware activation, and the chain activation functions.

A/D Converter (Max 32 Channels)
■ 12-bit A/D Converter

- Successive approximation type
- Built-in three units
- Conversion time: 0.5 μ s at 5 V
- Priority conversion available (priority at two levels)
- Scanning conversion mode
- Built-in FIFO for conversion data storage (for SCAN conversion: 16 steps, for priority conversion: 4 steps)

Base Timer (Max 16 channels)

Operation mode is selected from the following for each channel:

- 16-bit PWM timer
- 16-bit PPG timer
- 16-/32-bit reload timer
- 16-/32-bit PWC timer
- Event counter mode (External clock mode)

General Purpose I/O Port

This series can use its pins as general purpose I/O ports when they are not used for external bus or peripherals; moreover, the port relocate function is built in. It can set the I/O port to which the peripheral function can be allocated.

- Capable of pull-up control per pin
- Capable of reading pin level directly
- Built-in port-relocate function
- Up to 121 high-speed general-purpose I/O ports in 144-pin package
- Some pins 5 V tolerant I/O.
See 4. Pin Descriptions and 5. I/O Circuit Type for the corresponding pins.

Multi-function Timer (Max two units)

The multi-function timer is composed of the following blocks:

Minimum resolution: 5.56 ns

- 16-bit free-run timer \times 3 ch/unit
- Input capture \times 4 ch/unit
- Output compare \times 6 ch/unit
- A/D activation compare \times 6 ch/unit
- Waveform generator \times 3 ch/unit
- 16-bit PPG timer \times 3 ch/unit

The following functions can be used to achieve the motor control:

- PWM signal output function
- DC chopper waveform output function

- Dead time function
- Input capture function
- A/D convertor activate function
- DTIF (motor emergency stop) interrupt function

Real-Time Clock (RTC)

The real-time clock can count year, month, day, hour, minute, second, or day of the week from 00 to 99.

- Interrupt function with specifying date and time (year/month/day/hour/minute/second/day of the week) is available. This function is also available by specifying only year, month, day, hour, or minute.
- Timer interrupt function after set time or each set time.
- Capable of rewriting the time with continuing the time count.
- Leap year automatic count is available.

Quadrature Position/Revolution Counter (QPRC; Max four channels)

The Quadrature Position/Revolution Counter (QPRC) is used to measure the position of the position encoder. It is also possible to use up/down counter.

- The detection edge of the three external event input pins AIN, BIN and ZIN is configurable.
- 16-bit position counter
- 16-bit revolution counter
- Two 16-bit compare registers

Dual Timer (32-/16-bit Down Counter)

The dual timer consists of two programmable 32-/16-bit down counters.

Operation mode is selectable from the following for each channel:

- Free-running
- Periodic (= Reload)
- One shot

Watch Counter

The watch counter is used for wake up from low-power consumption mode. It is possible to select the main clock, sub clock, built-in High-speed CR clock, or built-in low-speed CR clock as the clock source.

- Interval timer: up to 64 s (max) with a sub clock of 32.768 kHz

External Interrupt Controller Unit

- External interrupt input pin: Max 32 pins
 - Both edges(Rise edge and Fall edge) detect
- Include one non-maskable interrupt (NMI)

Watchdog Timer (Two channels)

A watchdog timer can generate interrupts or a reset when a time-out value is reached.

This series consists of two different watchdogs: a hardware watchdog and a software watchdog.

The hardware watchdog timer is clocked by low-speed internal CR oscillator. The hardware watchdog is thus active in any power saving mode except RTC mode and Stop mode.

Cyclic Redundancy Check (CRC) Accelerator

The CRC accelerator helps to verify data transmission or storage integrity.

CCITT CRC16 and IEEE-802.3 CRC32 are supported.

- CCITT CRC16 generator polynomial: 0x1021
- IEEE-802.3 CRC32 generator polynomial: 0x04C11DB7

Ethernet-MAC

- Compliant with IEEE802.3 specification
- 10 Mbps/100 Mbps data transfer rates supported
- MII/RMII for external PHY device supported.
- MII: Max one channel
- RMII: Max one channel
- Full-duplex and half-duplex mode supported.
- Wake-ON-LAN supported
- Built-in dedicated descriptor-system DMAC
- Built-in 2 Kbytes transmit FIFO and 2 Kbytes receive FIFO.
- Compliant IEEE1558-2008 (PTP)

Smartcard Interface (Max 2 channels)

- Compliant with ISO7816-3 specification
- Card Reader only/B class card only
- Available protocols
 - Transmitter: 8E2, 8O2, 8N2
 - Receiver: 8E1, 8O1, 8N2, 8N1, 9N1
 - Inverse mode
- TX/RX FIFO integrated (RX: 16-bytes, TX:16-bytes)

Clock and Reset

- Clocks
Five clock sources (two external oscillators, two internal CR oscillators, and Main PLL) that are dynamically selectable.
 - Main clock: 4 MHz to 48 MHz
 - Sub clock: 30 kHz to 100 kHz
 - High-speed internal CR clock: 4 MHz
 - Low-speed internal CR clock: 100 kHz
 - Main PLL Clock
- Resets
 - Reset requests from INITX pin

- Power on reset
- Software reset
- Watchdog timer reset
- Low-voltage detector reset
- Clock supervisor reset

Clock Supervisor (CSV)

Clocks generated by internal CR oscillators are used to supervise abnormality of the external clocks.

- External OSC clock failure (clock stop) is detected, reset is asserted.
- External OSC frequency anomaly is detected, interrupt or reset is asserted.

Low-Voltage Detector (LVD)

This Series include two-stage monitoring of voltage on the VCC pins. when the voltage falls below the voltage that has been set, the low-voltage detector function generates an interrupt or reset.

- LVD1: error reporting via interrupt
- LVD2: auto-reset operation

Low-power Consumption Mode

Six low power consumption modes are supported.

- Sleep
- Timer
- RTC
- Stop
- Deep standby RTC (selectable from with/without RAM retention)
- Deep standby stop (selectable from with/without RAM retention)

Peripheral Clock Gating

The system can reduce the current consumption of the total system with gating the operation clocks of peripheral functions not used.

Crypto Assist Function

These features are enabled for the crypto assist function. The dedicated middleware is necessary for this calculator operation.

- PKA (Public Key Accelerator)
 - PKA (Public Key Accelerator) is modular exponentiation calculation accelerator used of RSA Public Key crypto and so on.
 - Available bit length: Up to 2048-bit
- AES calculator
 - AES (Advanced Encryption Standard) calculator is a AES common key crypto accelerator which is compliant with FIPS (Federal Information Processing Standard Publication)197.
 - Available key length: 128/192/256-bit
 - CBC mode and ECB mode support
- External Bus Data Scramble
 - It enables to scramble input/output data of External Bus Interface.

Debug

- Serial wire JTAG debug port (SWJ-DP)
- Embedded trace macrocells (ETM) provide comprehensive debug and trace facilities.
- AHB trace macrocells (HTM)

Unique ID

Unique value of the device (41-bit) is set.

Power Supply

- Five power supplies
 - Wide range voltage: VCC = 2.7 V to 5.5 V
 - Power supply for USB ch 0 I/O:
 - USBVCC0 = 3.0 V to 3.6 V (when USB is used)
 - = 2.7 V to 5.5 V (when GPIO is used)
 - Power supply for USB ch 1 I/O:
 - USBVCC1 = 3.0 V to 3.6 V (when USB is used)
 - = 2.7 V to 5.5 V (when GPIO is used)
 - Power supply for Ethernet-MAC I/O:
 - ETHVCC = 3.0 V to 5.5 V (when Ethernet is used.)

Table of Contents

| | |
|--|-----------|
| 1. Product Lineup | 7 |
| 2. Packages | 9 |
| 3. Pin Assignments | 10 |
| 4. Pin Descriptions | 12 |
| 5. I/O Circuit Type | 53 |
| 6. Handling Precautions | 60 |
| 6.1 Precautions for Product Design..... | 60 |
| 6.2 Precautions for Package Mounting..... | 61 |
| 6.3 Precautions for Use Environment..... | 63 |
| 7. Handling Devices | 64 |
| 8. Block Diagram | 67 |
| 9. Memory Size | 68 |
| 10. Memory Map | 68 |
| 11. Pin Status in Each CPU State | 72 |
| 12. Electrical Characteristics | 78 |
| 12.1 Absolute Maximum Ratings..... | 78 |
| 12.2 Recommended Operating Conditions..... | 79 |
| 12.3 DC Characteristics..... | 84 |
| 12.3.1 Current Rating..... | 84 |
| 12.3.2 Pin Characteristics..... | 94 |
| 12.4 AC Characteristics..... | 96 |
| 12.4.1 Main Clock Input Characteristics..... | 96 |
| 12.4.2 Sub Clock Input Characteristics..... | 97 |
| 12.4.3 Built-In CR Oscillation Characteristics..... | 97 |
| 12.4.4 Operating Conditions of Main PLL (in the Case of Using Main Clock for Input Clock of PLL)..... | 98 |
| 12.4.5 Operating Conditions of USB/Ethernet PLL (in the Case of Using Main Clock for Input Clock of PLL)..... | 98 |
| 12.4.6 Operating Conditions of Main PLL (in the Case of Using Built-in High-Speed CR Clock for Input Clock of Main PLL)..... | 99 |
| 12.4.7 Reset Input Characteristics..... | 99 |
| 12.4.8 Power-On Reset Timing..... | 100 |
| 12.4.9 GPIO Output Characteristics..... | 100 |
| 12.4.10 External Bus Timing..... | 101 |
| 12.4.11 Base Timer Input Timing..... | 112 |
| 12.4.12 CSIO (SPI) Timing..... | 113 |
| 12.4.13 External Input Timing..... | 146 |
| 12.4.14 Quadrature Position/Revolution Counter Timing..... | 147 |
| 12.4.15 I ² C Timing..... | 150 |
| 12.4.16 ETM/ HTM Timing..... | 152 |
| 12.4.17 JTAG Timing..... | 153 |
| 12.4.18 Ethernet-MAC Timing..... | 154 |
| 12.4.19 I ² S Timing (Multi-function Serial Interface)..... | 159 |
| 12.5 12-bit A/D Converter..... | 160 |
| 12.6 USB Characteristics..... | 163 |
| 12.7 Low-Voltage Detection Characteristics..... | 167 |
| 12.7.1 Low-Voltage Detection Reset..... | 167 |



12.7.2 Interrupt of Low-Voltage Detection 167

12.8 MainFlash Memory Write/Erase Characteristics 168

12.9 Standby Recovery Time 169

12.9.1 Recovery Cause: Interrupt/WKUP 169

12.9.2 Recovery Cause: Reset 171

13. Ordering Information 173

14. Package Dimensions 174

Sales, Solutions, and Legal Information 177

1. Product Lineup

Memory Size

| Product Name | | S6E2G26H/J | S6E2G28H/J |
|----------------------|-------|------------|-------------|
| On-chip flash memory | | 512 Kbytes | 1024 Kbytes |
| On-chip | SRAM | 128 Kbytes | 192 Kbytes |
| | SRAM0 | 64 Kbytes | 128 Kbytes |
| | SRAM1 | 32 Kbytes | 32 Kbytes |
| | SRAM2 | 32 Kbytes | 32 Kbytes |

Function

| Product Name | | S6E2G26H0A S6E2G28H0A S6E2G26HHA S6E2G28HHA | S6E2G26J0A S6E2G28J0A S6E2G26JHA S6E2G28JHA |
|--|------------------------|--|---|
| Pin count | | 144 | 176 |
| CPU | | Cortex-M4F, MPU, NVIC 128 ch | |
| Freq. | | 180 MHz | |
| Power supply voltage range | | 2.7 V to 5.5 V | |
| USB2.0 (Device/Host) | | 2 ch | |
| Ethernet-MAC | | 1ch.(Max) MII: 1 ch /RMII: 1 ch (Max) | |
| CAN | | N/A | |
| DMAC | | 8ch | |
| DSTC | | 256 ch | |
| External bus interface | | Addr: 25-bit (Max), Data: 8-/16-bit CS: 9 (Max), SRAM, NOR flash NAND flash SDRAM | Addr: 25-bit (Max), Data: 8-/16-bit CS: 9 (Max), SRAM, NOR flash , NAND flash SDRAM |
| Multi-function serial interface (UART/CSIO(SPI)/LIN/I ² C/I ² S) | | 10ch (Max) ch 1, ch 4 to ch 7: FIFO, ch 0, ch 2, ch3, ch 8 to ch 15: No FIFO ch 1: I ² S | |
| Base timer (PWC/Reload timer/PWM/PPG) | | 16 ch (Max) | |
| MF timer | A/D activation compare | 6 ch | 2 units (Max) |
| | Input capture | 4 ch | |
| | Free-run timer | 3 ch | |
| | Output compare | 6 ch | |
| | Waveform generator | 3 ch | |
| | PPG | 3 ch | |
| SD card interface | | N/A | |
| Smartcard (ISO7816) | | 2 ch (Max) | |
| QPRC | | 4 ch (Max) | |
| Dual timer | | 1 unit | |
| Real-time clock | | 1 unit | |
| Watch counter | | 1 unit | |
| CRC accelerator | | Yes (fixed) | |
| Watchdog timer | | 1 ch (SW) + 1 ch (HW) | |
| External interrupts | | 32 pins (Max)+ NMI x 1 | |
| I/O ports | | 121 pins (Max) | 153 pins (Max) |
| 12-bit A/D converter | | 24 ch (3 units) | 32 ch (3 units) |
| CSV (clock supervisor) | | Yes | |
| LVD (low-voltage detector) | | 2 ch | |
| Built-in CR High-speed | | 4 MHz (±2%) | |

| Product Name | S6E2G26H0A S6E2G28H0A S6E2G26HHA S6E2G28HHA | S6E2G26J0A S6E2G28J0A S6E2G26JHA S6E2G28JHA |
|------------------------|--|--|
| Low-speed | 100 kHz (Typ) | |
| Debug function | SWJ-DP/ETM/HTM | |
| Unique ID | Yes | |
| Crypto Assist Function | - | Yes ^{*1} |

*1: Crypto Assist Function is built in following products.
 S6E2G26HHA, S6E2G28HHA, S6E2G26JHA, S6E2G28JHA

Notes:

- All signals of the peripheral function in each product cannot be allocated by limiting the pins of package. It is necessary to use the port relocate function of the I/O port according to your function use.
- See 12.4.3 Built-In CR Oscillation Characteristics for the accuracy of the built-in CR.

2. Packages

| Package \ Product Name | S6E2GK6H0A S6E2GK8H0A S6E2GK6HHA S6E2GK8HHA | S6E2GK6J0A S6E2GK8J0A S6E2GK6JHA S6E2GK8JHA |
|-----------------------------------|--|--|
| LQFP: FPT-144P-M08 (0.5 mm pitch) | ○ | - |
| LQFP: FPT-176P-M07 (0.5 mm pitch) | - | ○ |

○: Supported

Note:

- See 14. Package Dimensions for detailed information on each package.

FPT-176P-M07

| | | | |
|-----|---------|-----|--|
| 176 | VSS | 131 | VSS |
| 177 | PH1UD00 | 132 | P83UDP1 |
| 178 | PH1UD00 | 133 | P83UDM1 |
| 179 | PH1UD00 | 134 | USBVCC1 |
| 180 | PH1UD00 | 135 | P20NMIX/WKUP0 |
| 181 | PH1UD00 | 136 | P21ADTG_0_SIN0_0INT27_0CROUT_0 |
| 182 | PH1UD00 | 137 | P22IAN1/ISOT0_0INT26_0 |
| 183 | PH1UD00 | 138 | P23IHCNKA1/AN53003_0TIOB13_1 |
| 184 | PH1UD00 | 139 | P24IAN2/TIOA13_1MAD18_0 |
| 185 | PH1UD00 | 140 | P25IAN2/TIOB_2INT25_0MAD17_0 |
| 186 | PH1UD00 | 141 | P26ADTG_0TIOA6_2INT11_2MAD16_0 |
| 187 | PH1UD00 | 142 | P27IAN2/SIN5_0INT24_0MAD15_0 |
| 188 | PH1UD00 | 143 | P28IAN2/SOT5_0INT10_2MAD14_0 |
| 189 | PH1UD00 | 144 | P29IAN2/SCK5_0INT09_2MAD13_0 |
| 190 | PH1UD00 | 145 | P30IAN2/ACT55_0INT08_2MAD12_0 |
| 191 | PH1UD00 | 146 | P31IAN1/SRT55_0TIOB8_1INT17_1MAD11_0 |
| 192 | PH1UD00 | 147 | P32IAN1/4SND_0TIOA8_1INT08_1MAD10_0 |
| 193 | PH1UD00 | 148 | P33IAN1/SOT0_0TIOB5_2MAD09_0 |
| 194 | PH1UD00 | 149 | P34IAN1/2SOT0_0TIOA3_2TRACED15 |
| 195 | PH1UD00 | 150 | P35IAN2/SOT8_0TIOA12_1BIN1_2TRACED14 |
| 196 | PH1UD00 | 151 | P36IAN2/SIN8_0TIOB11_1BIN1_2INT11_1TRACED13 |
| 197 | PH1UD00 | 152 | P37IAN2/SCK5_0TIOA1_1INT10_1TRACED12 |
| 198 | PH1UD00 | 153 | P38IAN1/TIOB4_2INT11_0TRACED7 |
| 199 | PH1UD00 | 154 | P39IAN1/SCK2_0TIOA4_2TRACED6 |
| 200 | PH1UD00 | 155 | P40IAN1/SOT2_0TIOB3_2INT24_0TRACED5 |
| 201 | PH1UD00 | 156 | P41IAN1/SIN2_0TIOA3_2INT10_0TRACED4 |
| 202 | PH1UD00 | 157 | P42IAN1/SCK2_0TIOA10_1BIN0_2INT09_1TRACED10 |
| 203 | PH1UD00 | 158 | P43IAN1/7SC56_0TIOB9_1BIN0_0TRACED9 |
| 204 | PH1UD00 | 159 | P44IAN1/SCK6_0TIOA6_1TRACED8 |
| 205 | PH1UD00 | 160 | P45IAN1/SOT6_1TRACED3 |
| 206 | PH1UD00 | 161 | P46IAN1/SIN9_1INT09_0TRACED2 |
| 207 | PH1UD00 | 162 | P47IAN1/SCK9_0TIOB2_2IC1_CN_0TRACED1 |
| 208 | PH1UD00 | 163 | P48IAN1/SOT9_0TIOA2_2IC1_DATA_0TRACED0 |
| 209 | PH1UD00 | 164 | P49IAN1/SIN9_0TIOB1_2INT25_1MNALE_0IC1_RST_0 |
| 210 | PH1UD00 | 165 | P50IAN2/TIOA1_2MNALE_0IC1_VPEN_0 |
| 211 | PH1UD00 | 166 | P51IAN1/7IOB9_2MNALE_0IC1_VCC_0 |
| 212 | PH1UD00 | 167 | P52IAN1/TIOA0_2INT09_0MNALE_0IC1_CLK_0 |
| 213 | PH1UD00 | 168 | AVRH |
| 214 | PH1UD00 | 169 | AVRL |
| 215 | PH1UD00 | 170 | AVSS |
| 216 | PH1UD00 | 171 | AVCC |
| 217 | PH1UD00 | 172 | VCC |

LQFP - 176

Note:

- The number after the underscore ("_") in pin names such as XXX_1 and XXX_2 indicates the relocated port number. For these pins, there are multiple pins that provide the same function for the same channel. Use the extended port function register (EPFR) to select the pin.

4. Pin Descriptions

List of Pin Functions

The number after the underscore ("_") in pin names such as XXX_1 and XXX_2 indicates the relocated port number. For these pins, there are multiple pins that provide the same function for the same channel.

Use the extended port function register (EPFR) to select the pin.

| Pin Number | | Pin Name | I/O Circuit Type | Pin State Type |
|------------|----------|----------------------|------------------|----------------|
| LQFP-176 | LQFP-144 | | | |
| 1 | 1 | VCC | - | - |
| 2 | 2 | PA0 | E | K |
| | | RTO00_1 (PPG00_1) | | |
| | | TIOA8_0 | | |
| | | INT00_0 | | |
| | | MADATAA00_0 | | |
| IC0_CIN_0 | | | | |
| 3 | 3 | PA1 | E | I |
| | | RTO01_1 (PPG01_1) | | |
| | | TIOA9_0 | | |
| | | MADATAA01_0 | | |
| IC0_DATA_0 | | | | |
| 4 | 4 | PA2 | E | I |
| | | RTO02_1 (PPG02_1) | | |
| | | TIOA10_0 | | |
| | | MADATAA02_0 | | |
| IC0_RST_0 | | | | |
| 5 | 5 | PA3 | E | I |
| | | RTO03_1 (PPG03_1) | | |
| | | TIOA11_0 | | |
| | | MADATAA03_0 | | |
| IC0_VPEN_0 | | | | |
| 6 | 6 | PA4 | E | I |
| | | RTO04_1 (PPG04_1) | | |
| | | TIOA12_0 | | |
| | | MADATAA04_0 | | |
| IC0_VCC_0 | | | | |
| 7 | 7 | PA5 | E | K |
| | | RTO05_1 (PPG05_1) | | |
| | | TIOA13_0 | | |
| | | INT01_0 | | |
| | | MADATAA05_0 | | |
| IC0_CLK_0 | | | | |

| Pin Number | | Pin Name | I/O Circuit Type | Pin State Type |
|------------|----------|--------------------|------------------|----------------|
| LQFP-176 | LQFP-144 | | | |
| 8 | 8 | PA6 | E | K |
| | | DTTI0X_1 | | |
| | | INT00_2 | | |
| | | MADATA06_0 | | |
| 9 | 9 | PA7 | E | K |
| | | IC00_1 | | |
| | | INT02_2 | | |
| | | MADATA07_0 | | |
| | | RTCCO_1 | | |
| 10 | - | SUBOUT_1 | E | I |
| | | P50 | | |
| | | SCS72_0 | | |
| | | IC01_1 | | |
| 11 | - | TIOA8_2 | E | I |
| | | P51 | | |
| | | SCS73_0 | | |
| | | IC02_1 | | |
| 12 | - | TIOB8_2 | E | I |
| | | P52 | | |
| | | IC03_1 | | |
| 13 | 10 | TIOA9_2 | I | Q |
| | | PA8 | | |
| | | SIN7_0 | | |
| | | FRCK0_1 | | |
| | | INT02_0 | | |
| | | WKUP1 | | |
| MADATA08_0 | | | | |
| 14 | 11 | PA9 | N | I |
| | | SOT7_0 (SDA7_0) | | |
| | | AIN1_1 | | |
| | | MADATA09_0 | | |
| 15 | 12 | PAA | N | I |
| | | SCK7_0, (SCL7_0) | | |
| | | BIN1_1 | | |
| | | MADATA10_0 | | |
| 16 | 13 | PAB | E | K |
| | | SCS70_0 | | |
| | | ZIN1_1 | | |
| | | INT03_0 | | |
| | | MADATA11_0 | | |
| 17 | 14 | PAC | E | I |
| | | SCS71_0 | | |
| | | TIOB8_0 | | |
| | | MADATA12_0 | | |

| Pin Number | | Pin Name | I/O Circuit Type | Pin State Type |
|------------|----------|--------------------|------------------|----------------|
| LQFP-176 | LQFP-144 | | | |
| 18 | 15 | PAD | N | I |
| | | SCK3_0 (SCL3_0) | | |
| | | TIOB9_0 | | |
| | | MADATA13_0 | | |
| 19 | 16 | PAE | N | I |
| | | ADTG_0 | | |
| | | SOT3_0 (SDA3_0) | | |
| | | TIOB10_0 | | |
| | | MADATA14_0 | | |
| 20 | 17 | PAF | I | K |
| | | SIN3_0 | | |
| | | TIOB11_0 | | |
| | | INT16_0 | | |
| | | MADATA15_0 | | |
| 21 | 18 | P08 | E | K |
| | | TIOB12_0 | | |
| | | INT17_0 | | |
| | | MDQM0_0 | | |
| 22 | 19 | P09 | E | K |
| | | TIOB13_0 | | |
| | | INT18_0 | | |
| | | MDQM1_0 | | |
| 23 | 20 | P0A | L | I |
| | | ADTG_1 | | |
| | | MCLKOUT_0 | | |
| 24 | - | P30 | E | K |
| | | M12SWS1_1 | | |
| | | TIOB11_2 | | |
| | | INT01_2 | | |
| 25 | - | P31 | E | I |
| | | M12SMCK1_1 | | |
| | | TIOA12_2 | | |
| 26 | 21 | P32 | L | K |
| | | INT19_0 | | |
| 27 | 22 | P33 | L | I |
| | | FRCK0_0 | | |
| 28 | 23 | P34 | L | K |
| | | IC03_0 | | |
| | | INT00_1 | | |
| 29 | 24 | VCC | - | - |
| 30 | 25 | VSS | - | - |
| 31 | 26 | P35 | L | K |

| Pin Number | | Pin Name | I/O Circuit Type | Pin State Type |
|------------|----------|----------------------|------------------|----------------|
| LQFP-176 | LQFP-144 | | | |
| | | IC02_0 | | |
| | | INT01_1 | | |
| 32 | 27 | P36 | L | K |
| | | IC01_0 | | |
| | | INT02_1 | | |
| 33 | 28 | P37 | L | K |
| | | IC00_0 | | |
| | | INT03_1 | | |
| 34 | 29 | P38 | E | I |
| | | ADTG_2 | | |
| | | DTTI0X_0 | | |
| 35 | 30 | P39 | G | K |
| | | RTO00_0 (PPG00_0) | | |
| | | TIOA0_1 | | |
| | | AIN1_0 | | |
| | | INT16_1 | | |
| MAD24_0 | | | | |
| 36 | 31 | P3A | G | K |
| | | RTO01_0 (PPG01_0) | | |
| | | TIOA1_1 | | |
| | | BIN1_0 | | |
| | | INT17_1 | | |
| MAD23_0 | | | | |
| 37 | 32 | P3B | G | K |
| | | RTO02_0 (PPG02_0) | | |
| | | TIOA2_1 | | |
| | | ZIN1_0 | | |
| | | INT18_1 | | |
| MAD22_0 | | | | |
| 38 | 33 | P3C | G | K |
| | | SIN2_1 | | |
| | | RTO03_0 (PPG03_0) | | |
| | | TIOA3_1 | | |
| | | INT19_1 | | |
| MAD21_0 | | | | |
| 39 | 34 | P3D | G | I |
| | | SOT2_1 (SDA2_1) | | |
| | | RTO04_0 (PPG04_0) | | |

| Pin Number | | Pin Name | I/O Circuit Type | Pin State Type |
|------------|----------|----------------------|------------------|----------------|
| LQFP-176 | LQFP-144 | | | |
| | | TIOA4_1 | | |
| | | MAD20_0 | | |
| 40 | 35 | P3E | G | I |
| | | SCK2_1 (SCL2_1) | | |
| | | RTO05_0 (PPG05_0) | | |
| | | TIOA5_1 | | |
| | | MAD19_0 | | |
| 41 | - | P5D | E | K |
| | | SIN1_1 | | |
| | | M2SDI1_1 | | |
| | | TIOB12_2 | | |
| | | INT03_2 | | |
| 42 | - | P5E | E | I |
| | | SOT1_1 (SDA1_1) | | |
| | | M2SDO1_1 | | |
| | | TIOA13_2 | | |
| 43 | - | P5F | E | I |
| | | SCK1_1 (SCL1_1) | | |
| | | M2SCK1_1 | | |
| | | TIOB13_2 | | |
| 44 | 36 | VSS | - | - |
| 45 | 37 | VCC | - | - |
| 46 | 38 | P40 | G | K |
| | | SIN7_1 | | |
| | | RTO10_0 (PPG10_0) | | |
| | | TIOA0_0 | | |
| | | AIN0_0 | | |
| | | INT23_0 | | |
| | | MCSX7_0 | | |
| 47 | 39 | P41 | G | I |
| | | SOT7_1 (SDA7_1) | | |
| | | RTO11_0 (PPG11_0) | | |
| | | TIOA1_0 | | |
| | | BIN0_0 | | |
| | | MCSX6_0 | | |

| Pin Number | | Pin Name | I/O Circuit Type | Pin State Type |
|------------|----------|----------------------|------------------|----------------|
| LQFP-176 | LQFP-144 | | | |
| 48 | 40 | P42 | G | I |
| | | SCK7_1 (SCL7_1) | | |
| | | RTO12_0 (PPG12_0) | | |
| | | TIOA2_0 | | |
| | | ZIN0_0 | | |
| | | MCSX5_0 | | |
| 49 | 41 | P43 | G | K |
| | | SCS70_1 | | |
| | | RTO13_0 (PPG13_0) | | |
| | | TIOA3_0 | | |
| | | INT04_0 | | |
| | | MCSX4_0 | | |
| 50 | 42 | P44 | G | I |
| | | SCS71_1 | | |
| | | RTO14_0 (PPG14_0) | | |
| | | TIOA4_0 | | |
| | | MCSX3_0 | | |
| 51 | 43 | P45 | G | I |
| | | SCS72_1 | | |
| | | RTO15_0 (PPG15_0) | | |
| | | TIOA5_0 | | |
| | | MCSX2_0 | | |
| 52 | 44 | C | - | - |
| 53 | 45 | VSS | - | - |
| 54 | 46 | VCC | - | - |
| 55 | 47 | P46 | D | S |
| | | X0A | | |
| 56 | 48 | P47 | D | T |
| | | X1A | | |
| 57 | 49 | INITX | B | C |
| 58 | - | PF0 | E | K |
| | | SCS73_1 | | |
| | | TIOA15_1 | | |
| | | INT22_1 | | |
| 59 | - | PF1 | E | K |
| | | TIOB15_1 | | |
| | | INT23_1 | | |
| 60 | 50 | P48 | L | K |
| | | SIN1_0 | | |
| | | M2SDI1_0 | | |

| Pin Number | | Pin Name | I/O Circuit Type | Pin State Type |
|------------|----------|--------------------|------------------|----------------|
| LQFP-176 | LQFP-144 | | | |
| | | DTTI1X_0 | | |
| | | INT06_0 | | |
| | | MRASX_0 | | |
| 61 | 51 | P49 | L | I |
| | | SOT1_0 (SDA1_0) | | |
| | | M2SDO1_0 | | |
| | | IC10_0 | | |
| | | MCASX_0 | | |
| 62 | 52 | P4A | L | I |
| | | SCK1_0 (SCL1_0) | | |
| | | M2SCK1_0 | | |
| | | IC11_0 | | |
| | | MSDWEX_0 | | |
| 63 | 53 | P4B | L | K |
| | | M2SWS1_0 | | |
| | | IC12_0 | | |
| | | INT04_2 | | |
| | | MCSX8_0 | | |
| 64 | 54 | P4C | L | K |
| | | M2SMCK1_0 | | |
| | | IC13_0 | | |
| | | INT05_2 | | |
| | | MSDCKE_0 | | |
| 65 | 55 | P4D | L | K |
| | | FRCK1_0 | | |
| | | INT07_0 | | |
| | | MSDCLK_0 | | |
| 66 | 56 | P4E | L | Q |
| | | SCK9_0 (SCL9_0) | | |
| | | INT05_0 | | |
| | | WKUP2 | | |
| | | MCSX1_0 | | |
| 67 | 57 | P70 | L | I |
| | | ADTG_7 | | |
| | | SOT9_0 (SDA9_0) | | |
| | | MCSX0_0 | | |
| 68 | 58 | P71 | I | K |
| | | ADTG_8 | | |
| | | SIN9_0 | | |
| | | INT04_1 | | |
| | | MRDY_0 | | |

| Pin Number | | Pin Name | I/O Circuit Type | Pin State Type |
|------------|----------|--------------------|------------------|----------------|
| LQFP-176 | LQFP-144 | | | |
| 69 | 59 | P72 | E | I |
| | | TIOB0_0 | | |
| | | INT06_2 | | |
| | | MAD00_0 | | |
| 70 | 60 | P73 | E | K |
| | | SIN8_0 | | |
| | | TIOB1_0 | | |
| | | INT20_0 | | |
| 71 | 61 | P74 | E | I |
| | | SOT8_0 (SDA8_0) | | |
| | | TIOB2_0 | | |
| | | MAD02_0 | | |
| 72 | 62 | P75 | E | I |
| | | SCK8_0 (SCL8_0) | | |
| | | TIOB3_0 | | |
| | | MAD03_0 | | |
| 73 | 63 | P76 | E | K |
| | | SIN6_0 | | |
| | | TIOB4_0 | | |
| | | INT21_0 | | |
| 74 | 64 | P77 | L | I |
| | | SOT6_0 (SDA6_0) | | |
| | | TIOB5_0 | | |
| | | MAD05_0 | | |
| 75 | 65 | P78 | L | I |
| | | SCK6_0 (SCL6_0) | | |
| | | AIN0_1 | | |
| | | MAD06_0 | | |
| 76 | 66 | P79 | E | K |
| | | SCS60_0 | | |
| | | BIN0_1 | | |
| | | INT22_0 | | |
| 77 | 67 | P7A | E | K |
| | | SCS61_0 | | |
| | | ZIN0_1 | | |
| | | INT07_2 | | |
| 78 | - | PF2 | E | I |

| Pin Number | | Pin Name | I/O Circuit Type | Pin State Type |
|------------|----------|--------------------|------------------|----------------|
| LQFP-176 | LQFP-144 | | | |
| | | SCS62_0 | | |
| | | DTT11X_1 | | |
| | | TIOA6_1 | | |
| | | IC1_CLK_1 | | |
| 79 | - | PF3 | E | K |
| | | SCS63_0 | | |
| | | FRCK1_1 | | |
| | | TIOB6_1 | | |
| | | INT05_1 | | |
| | | IC1_VCC_1 | | |
| 80 | - | PF4 | E | K |
| | | IC10_1 | | |
| | | TIOA7_1 | | |
| | | INT06_1 | | |
| | | IC1_VPEN_1 | | |
| 81 | - | PF5 | E | K |
| | | SIN3_1 | | |
| | | IC11_1 | | |
| | | TIOB7_1 | | |
| | | INT07_1 | | |
| | | IC1_RST_1 | | |
| 82 | - | PF6 | E | K |
| | | SOT3_1 (SDA3_1) | | |
| | | IC12_1 | | |
| | | TIOA14_1 | | |
| | | INT20_1 | | |
| | | IC1_DATA_1 | | |
| 83 | - | PF7 | E | K |
| | | SCK3_1 (SCL3_1) | | |
| | | IC13_1 | | |
| | | TIOB14_1 | | |
| | | INT21_1 | | |
| | | IC1_CIN_1 | | |
| 84 | 68 | PE0 | C | E |
| | | MD1 | | |
| 85 | 69 | MD0 | J | D |
| 86 | 70 | PE2 | A | A |
| | | X0 | | |
| 87 | 71 | PE3 | A | B |
| | | X1 | | |
| 88 | 72 | VSS | - | - |
| 89 | 73 | VCC | - | - |
| 90 | 74 | AVCC | - | - |

| Pin Number | | Pin Name | I/O Circuit Type | Pin State Type |
|------------|----------|--------------------|------------------|----------------|
| LQFP-176 | LQFP-144 | | | |
| 91 | 75 | AVSS | - | - |
| 92 | 76 | AVRL | - | - |
| 93 | 77 | AVRH | - | - |
| 94 | 78 | P10 | F | M |
| | | AN00 | | |
| | | TIOA0_2 | | |
| | | INT08_0 | | |
| | | MNREX_0 | | |
| | | IC1_CLK_0 | | |
| 95 | 79 | P11 | F | L |
| | | AN01 | | |
| | | TIOB0_2 | | |
| | | MNWEX_0 | | |
| | | IC1_VCC_0 | | |
| 96 | 80 | P12 | F | L |
| | | AN02 | | |
| | | TIOA1_2 | | |
| | | MNCLE_0 | | |
| | | IC1_VPEN_0 | | |
| 97 | 81 | P13 | F | M |
| | | AN03 | | |
| | | SIN9_1 | | |
| | | TIOB1_2 | | |
| | | INT25_1 | | |
| | | MNALE_0 | | |
| | | IC1_RST_0 | | |
| 98 | 82 | P14 | F | N |
| | | AN04 | | |
| | | SOT9_1 (SDA9_1) | | |
| | | TIOA2_2 | | |
| | | IC1_DATA_0 | | |
| | | TRACED0 | | |
| 99 | 83 | P15 | F | N |
| | | AN05 | | |
| | | SCK9_1 (SCL9_1) | | |
| | | TIOB2_2 | | |
| | | IC1_CIN_0 | | |
| | | TRACED1 | | |
| 100 | 84 | P16 | F | O |
| | | AN06 | | |
| | | SIN6_1 | | |
| | | INT09_0 | | |
| | | TRACED2 | | |

| Pin Number | | Pin Name | I/O Circuit Type | Pin State Type |
|------------|----------|---------------------|------------------|----------------|
| LQFP-176 | LQFP-144 | | | |
| 101 | 85 | P17 | F | N |
| | | AN07 | | |
| | | SOT6_1 (SDA6_1) | | |
| | | TRACED3 | | |
| 102 | - | PB0 | F | N |
| | | AN16 | | |
| | | SCK6_1 (SCL6_1) | | |
| | | TIOA9_1 TRACED8 | | |
| 103 | - | PB1 | F | O |
| | | AN17 | | |
| | | SCS60_1 | | |
| | | TIOB9_1 | | |
| | | AIN0_2 | | |
| | | INT08_1 TRACED9 | | |
| 104 | - | PB2 | F | O |
| | | AN18 | | |
| | | SCS61_1 | | |
| | | TIOA10_1 | | |
| | | BIN0_2 | | |
| | | INT09_1 TRACED10 | | |
| 105 | - | PB3 | F | N |
| | | AN19 | | |
| | | SCS62_1 | | |
| | | TIOB10_1 | | |
| | | ZIN0_2 TRACED11 | | |
| 106 | 86 | P18 | F | O |
| | | AN08 | | |
| | | SIN2_0 | | |
| | | TIOA3_2 | | |
| | | INT10_0 TRACED4 | | |
| 107 | 87 | P19 | F | O |
| | | AN09 | | |
| | | SOT2_0 (SDA2_0) | | |
| | | TIOB3_2 | | |
| | | INT24_1 TRACED5 | | |
| 108 | 88 | P1A | F | N |

| Pin Number | | Pin Name | I/O Circuit Type | Pin State Type |
|------------|----------|--------------------|------------------|----------------|
| LQFP-176 | LQFP-144 | | | |
| | | AN10 | | |
| | | SCK2_0 (SCL2_0) | | |
| | | TIOA4_2 | | |
| | | TRACED6 | | |
| 109 | 89 | PIB | F | O |
| | | AN11 | | |
| | | TIOB4_2 | | |
| | | INT11_0 | | |
| | | TRACED7 | | |
| 110 | - | PB4 | F | O |
| | | AN20 | | |
| | | SCS63_1 | | |
| | | TIOA11_1 | | |
| | | INT10_1 | | |
| | | TRACED12 | | |
| 111 | - | PB5 | F | O |
| | | AN21 | | |
| | | SIN8_1 | | |
| | | TIOB11_1 | | |
| | | AIN1_2 | | |
| | | INT11_1 | | |
| | | TRACED13 | | |
| 112 | - | PB6 | F | N |
| | | AN22 | | |
| | | SOT8_1 (SDA8_1) | | |
| | | TIOA12_1 | | |
| | | BIN1_2 | | |
| | | TRACED14 | | |
| 113 | - | PB7 | F | N |
| | | AN23 | | |
| | | SCK8_1 (SCL8_1) | | |
| | | TIOB12_1 | | |
| | | ZIN1_2 | | |
| | | TRACED15 | | |
| 114 | 90 | PIC | F | N |
| | | AN12 | | |
| | | SCK0_1 (SCL0_1) | | |
| | | TIOA5_2 | | |
| | | TRACECLK | | |
| 115 | 91 | PID | F | L |

| Pin Number | | Pin Name | I/O Circuit Type | Pin State Type |
|------------|----------|--------------------|------------------|----------------|
| LQFP-176 | LQFP-144 | | | |
| | | AN13 | | |
| | | SOT0_1 (SDA0_1) | | |
| | | TIOB5_2 | | |
| | | MAD09_0 | | |
| 116 | 92 | PIE | F | M |
| | | AN14 | | |
| | | SIN0_1 | | |
| | | TIOA8_1 | | |
| | | INT26_1 | | |
| | | MAD10_0 | | |
| 117 | 93 | PIF | F | M |
| | | AN15 | | |
| | | RTS5_0 | | |
| | | TIOB8_1 | | |
| | | INT27_1 | | |
| | | MAD11_0 | | |
| 118 | 94 | P2A | F | M |
| | | AN24 | | |
| | | CTS5_0 | | |
| | | INT08_2 | | |
| | | MAD12_0 | | |
| 119 | 95 | P29 | F | M |
| | | AN25 | | |
| | | SCK5_0 (SCL5_0) | | |
| | | INT09_2 | | |
| | | MAD13_0 | | |
| 120 | 96 | P28 | F | M |
| | | AN26 | | |
| | | SOT5_0 (SDA5_0) | | |
| | | INT10_2 | | |
| | | MAD14_0 | | |
| 121 | 97 | P27 | F | M |
| | | AN27 | | |
| | | SIN5_0 | | |
| | | INT24_0 | | |
| | | MAD15_0 | | |
| 122 | 98 | P26 | E | M |
| | | ADTG_6 | | |
| | | TIOA6_2 | | |
| | | INT11_2 | | |
| | | MAD16_0 | | |
| 123 | 99 | P25 | F | M |

| Pin Number | | Pin Name | I/O Circuit Type | Pin State Type |
|------------|----------|--------------------|------------------|----------------|
| LQFP-176 | LQFP-144 | | | |
| | | AN28 | | |
| | | TIOB6_2 | | |
| | | INT25_0 | | |
| | | MAD17_0 | | |
| 124 | 100 | P24 | F | L |
| | | AN29 | | |
| | | TIOA13_1 | | |
| | | MAD18_0 | | |
| 125 | 101 | P23 | F | L |
| | | UHCONX1 | | |
| | | AN30 | | |
| | | SCK0_0 (SCL0_0) | | |
| | | TIOB13_1 | | |
| 126 | 102 | P22 | E | M |
| | | AN31 | | |
| | | SOT0_0 (SDA0_0) | | |
| | | INT26_0 | | |
| 127 | 103 | P21 | I | K |
| | | ADTG_4 | | |
| | | SIN0_0 | | |
| | | INT27_0 | | |
| | | CROUT_0 | | |
| 128 | 104 | P20 | I | F |
| | | NMIX | | |
| | | WKUP0 | | |
| 129 | 105 | USBVCC1 | - | - |
| 130 | 106 | P82 | H | R |
| | | UDM1 | | |
| 131 | 107 | P83 | H | R |
| | | UDP1 | | |
| 132 | 108 | VSS | - | - |
| 133 | 109 | VCC | - | - |
| 134 | 110 | P00 | E | G |
| | | TRSTX | | |
| 135 | 111 | P01 | E | G |
| | | TCK | | |
| | | SWCLK | | |
| 136 | 112 | P02 | E | G |
| | | TDI | | |
| 137 | 113 | P03 | E | G |
| | | TMS | | |
| | | SWDIO | | |
| 138 | 114 | P04 | E | G |

| Pin Number | | Pin Name | I/O Circuit Type | Pin State Type |
|------------|----------|----------------------|------------------|----------------|
| LQFP-176 | LQFP-144 | | | |
| | | TDO | | |
| | | SWO | | |
| 139 | - | P90 | E | K |
| | | RTO10_1 (PPG10_1) | | |
| | | TIOB0_1 | | |
| | | INT12_1 | | |
| | | IC0_CLK_1 | | |
| 140 | - | P91 | E | K |
| | | SIN5_1 | | |
| | | RTO11_1 (PPG11_1) | | |
| | | TIOB1_1 | | |
| | | INT13_1 | | |
| | | IC0_VCC_1 | | |
| 141 | - | P92 | E | K |
| | | SOT5_1 (SDA5_1) | | |
| | | RTO12_1 (PPG12_1) | | |
| | | TIOB2_1 | | |
| | | INT14_1 | | |
| | | IC0_VPEN_1 | | |
| 142 | - | P93 | E | K |
| | | SCK5_1 (SCL5_1) | | |
| | | RTO13_1 (PPG13_1) | | |
| | | TIOB3_1 | | |
| | | INT15_1 | | |
| | | IC0_RST_1 | | |
| 143 | - | P94 | E | I |
| | | CTS5_1 | | |
| | | RTO14_1 (PPG14_1) | | |
| | | TIOB4_1 | | |
| | | IC0_DATA_1 | | |
| 144 | - | P95 | E | I |
| | | RTS5_1 | | |
| | | RTO15_1 (PPG15_1) | | |
| | | TIOB5_1 | | |
| | | IC0_CIN_1 | | |
| 145 | 115 | PC0 | K | V |
| | | E_RXER | | |

| Pin Number | | Pin Name | I/O Circuit Type | Pin State Type |
|------------|----------|--------------------|------------------|----------------|
| LQFP-176 | LQFP-144 | | | |
| 146 | 116 | PC1 | K | V |
| | | TIOB6_0 | | |
| | | E_RX03 | | |
| 147 | 117 | PC2 | K | V |
| | | TIOA6_0 | | |
| | | E_RX02 | | |
| 148 | 118 | PC3 | K | V |
| | | TIOB7_0 | | |
| | | E_RX01 | | |
| 149 | 119 | PC4 | K | V |
| | | TIOA7_0 | | |
| | | E_RX00 | | |
| 150 | 120 | PC5 | K | V |
| | | TIOB14_0 | | |
| | | E_RXDV | | |
| 151 | 121 | PC6 | K | V |
| | | TIOA14_0 | | |
| | | E_MDIO | | |
| 152 | 122 | PC7 | E | W |
| | | INT13_0 | | |
| | | E_MDC | | |
| | | CROUT_1 | | |
| 153 | 123 | PC8 | K | V |
| | | E_RXCK_REFCK | | |
| 154 | 124 | PC9 | K | V |
| | | TIOB15_0 | | |
| | | E_COL | | |
| 155 | 125 | PCA | K | V |
| | | TIOA15_0 | | |
| | | E_CRS | | |
| 156 | 126 | ETHVCC | - | - |
| 157 | 127 | VSS | - | - |
| 158 | 128 | PCB | L | W |
| | | INT28_0 | | |
| | | E_COUT | | |
| 159 | 129 | PCC | K | V |
| | | E_TCK | | |
| 160 | 130 | PCD | L | W |
| | | SOT4_1 (SDA4_1) | | |
| | | INT14_0 | | |
| | | E_TXER | | |
| 161 | 131 | PCE | L | W |
| | | SIN4_1 | | |
| | | INT15_0 | | |

| Pin Number | | Pin Name | I/O Circuit Type | Pin State Type |
|------------|----------|--------------------|------------------|----------------|
| LQFP-176 | LQFP-144 | | | |
| | | E_TX03 | | |
| 162 | 132 | PCF | L | W |
| | | RTS4_1 | | |
| | | INT12_0 | | |
| | | E_TX02 | | |
| 163 | 133 | PD0 | L | W |
| | | INT30_1 | | |
| | | E_TX01 | | |
| 164 | 134 | PD1 | L | W |
| | | INT31_1 | | |
| | | E_TX00 | | |
| 165 | 135 | PD2 | L | V |
| | | CTS4_1 | | |
| | | E_TXEN | | |
| 166 | 136 | P6E | E | W |
| | | ADTG_5 | | |
| | | SCK4_1 (SCL4_1) | | |
| | | INT29_0 | | |
| | | E_PPS | | |
| 167 | - | P65 | E | K |
| | | INT28_1 | | |
| 168 | - | P64 | I | K |
| | | CTS4_0 | | |
| | | INT29_1 | | |
| 169 | 137 | P63 | L | K |
| | | ADTG_3 | | |
| | | RTS4_0 | | |
| | | INT30_0 | | |
| | | MOEX_0 | | |
| 170 | 138 | P62 | L | I |
| | | SCK4_0 (SCL4_0) | | |
| | | TIOB7_2 | | |
| | | MWEX_0 | | |
| 171 | 139 | P61 | L | I |
| | | UHCONX0 | | |
| | | SOT4_0 (SDA4_0) | | |
| | | TIOA7_2 | | |
| | | MALE_0 | | |
| | | RTCCO_0 | | |
| | | SUBOUT_0 | | |
| 172 | 140 | P60 | I | Q |
| | | SIN4_0 | | |

| Pin Number | | Pin Name | I/O Circuit Type | Pin State Type |
|------------|----------|----------|------------------------|-------------------|
| LQFP-176 | LQFP-144 | | | |
| | | INT31_0 | | |
| | | WKUP3 | | |
| 173 | 141 | USBVCC0 | - | - |
| 174 | 142 | P80 | H | R |
| | | UDM0 | | |
| 175 | 143 | P81 | H | R |
| | | UDP0 | | |
| 176 | 144 | VSS | - | - |

Signal Descriptions

The number after the underscore ("_") in pin names such as XXX_1 and XXX_2 indicates the relocated port number. For these pins, there are multiple pins that provide the same function for the same channel.

Use the extended port function register (EPFR) to select the pin.

| Module | Pin Name | Function | Pin Number | |
|---------------|----------|--|-------------|-------------|
| | | | LQFP 176 | LQFP 144 |
| A/D converter | ADTG_0 | A/D converter external trigger input pin | 19 | 16 |
| | ADTG_1 | | 23 | 20 |
| | ADTG_2 | | 34 | 29 |
| | ADTG_3 | | 169 | 137 |
| | ADTG_4 | | 127 | 103 |
| | ADTG_5 | | 166 | 136 |
| | ADTG_6 | | 122 | 98 |
| | ADTG_7 | | 67 | 57 |
| | ADTG_8 | | 68 | 58 |
| | AN00 | A/D converter analog input pin. ANxx describes A/D converter ch xx. | 94 | 78 |
| | AN01 | | 95 | 79 |
| | AN02 | | 96 | 80 |
| | AN03 | | 97 | 81 |
| | AN04 | | 98 | 82 |
| | AN05 | | 99 | 83 |
| | AN06 | | 100 | 84 |
| | AN07 | | 101 | 85 |
| | AN08 | | 106 | 86 |
| | AN09 | | 107 | 87 |
| | AN10 | | 108 | 88 |
| | AN11 | | 109 | 89 |
| | AN12 | | 114 | 90 |
| | AN13 | | 115 | 91 |
| | AN14 | | 116 | 92 |
| | AN15 | | 117 | 93 |
| | AN16 | | 102 | - |
| | AN17 | | 103 | - |
| | AN18 | | 104 | - |
| | AN19 | | 105 | - |
| | AN20 | | 110 | - |
| | AN21 | | 111 | - |
| | AN22 | | 112 | - |
| | AN23 | | 113 | - |
| AN24 | 118 | | 94 | |
| AN25 | 119 | | 95 | |
| AN26 | 120 | | 96 | |
| AN27 | 121 | | 97 | |
| AN28 | 123 | | 99 | |
| AN29 | 124 | | 100 | |
| AN30 | 125 | | 101 | |
| AN31 | 126 | | 102 | |

| Module | Pin Name | Function | Pin Number | |
|-----------------|----------|--------------------------|-------------|-------------|
| | | | LQFP 176 | LQFP 144 |
| Base Timer 0 | TIOA0_0 | Base Timer ch 0 TIOA pin | 46 | 38 |
| | TIOA0_1 | | 35 | 30 |
| | TIOA0_2 | | 94 | 78 |
| | TIOB0_0 | Base Timer ch 0 TIOB pin | 69 | 59 |
| | TIOB0_1 | | 139 | - |
| | TIOB0_2 | | 95 | 79 |
| Base Timer 1 | TIOA1_0 | Base Timer ch 1 TIOA pin | 47 | 39 |
| | TIOA1_1 | | 36 | 31 |
| | TIOA1_2 | | 96 | 80 |
| | TIOB1_0 | Base Timer ch 1 TIOB pin | 70 | 60 |
| | TIOB1_1 | | 140 | - |
| | TIOB1_2 | | 97 | 81 |
| Base Timer 2 | TIOA2_0 | Base Timer ch 2 TIOA pin | 48 | 40 |
| | TIOA2_1 | | 37 | 32 |
| | TIOA2_2 | | 98 | 82 |
| | TIOB2_0 | Base Timer ch 2 TIOB pin | 71 | 61 |
| | TIOB2_1 | | 141 | - |
| | TIOB2_2 | | 99 | 83 |
| Base Timer 3 | TIOA3_0 | Base Timer ch 3 TIOA pin | 49 | 41 |
| | TIOA3_1 | | 38 | 33 |
| | TIOA3_2 | | 106 | 86 |
| | TIOB3_0 | Base Timer ch 3 TIOB pin | 72 | 62 |
| | TIOB3_1 | | 142 | - |
| | TIOB3_2 | | 107 | 87 |
| Base Timer 4 | TIOA4_0 | Base Timer ch 4 TIOA pin | 50 | 42 |
| | TIOA4_1 | | 39 | 34 |
| | TIOA4_2 | | 108 | 88 |
| | TIOB4_0 | Base Timer ch 4 TIOB pin | 73 | 63 |
| | TIOB4_1 | | 143 | - |
| | TIOB4_2 | | 109 | 89 |
| Base Timer 5 | TIOA5_0 | Base Timer ch 5 TIOA pin | 51 | 43 |
| | TIOA5_1 | | 40 | 35 |
| | TIOA5_2 | | 114 | 90 |
| | TIOB5_0 | Base Timer ch 5 TIOB pin | 74 | 64 |
| | TIOB5_1 | | 144 | - |
| | TIOB5_2 | | 115 | 91 |
| Base Timer 6 | TIOA6_0 | Base Timer ch 6 TIOA pin | 147 | 117 |
| | TIOA6_1 | | 78 | - |
| | TIOA6_2 | | 122 | 98 |
| | TIOB6_0 | Base Timer ch 6 TIOB pin | 146 | 116 |
| | TIOB6_1 | | 79 | - |
| | TIOB6_2 | | 123 | 99 |

| Module | Pin Name | Function | Pin Number | |
|---------------|----------|---------------------------------------|------------|----------|
| | | | LQFP 176 | LQFP 144 |
| Base Timer 7 | TIOA7_0 | Base Timer ch 7 TIOA pin | 149 | 119 |
| | TIOA7_1 | | 80 | - |
| | TIOA7_2 | | 171 | 139 |
| | TIOB7_0 | Base Timer ch 7 TIOB pin | 148 | 118 |
| | TIOB7_1 | | 81 | - |
| | TIOB7_2 | | 170 | 138 |
| Base Timer 8 | TIOA8_0 | Base Timer ch 8 TIOA pin | 2 | 2 |
| | TIOA8_1 | | 116 | 92 |
| | TIOA8_2 | | 10 | - |
| | TIOB8_0 | Base Timer ch 8 TIOB pin | 17 | 14 |
| | TIOB8_1 | | 117 | 93 |
| | TIOB8_2 | | 11 | - |
| Base Timer 9 | TIOA9_0 | Base Timer ch 9 TIOA pin | 3 | 3 |
| | TIOA9_1 | | 102 | - |
| | TIOA9_2 | | 12 | - |
| | TIOB9_0 | Base Timer ch 9 TIOB pin | 18 | 15 |
| | TIOB9_1 | | 103 | - |
| Base Timer 10 | TIOA10_0 | Base Timer ch 10 TIOA pin | 4 | 4 |
| | TIOA10_1 | | 104 | - |
| | TIOB10_0 | Base Timer ch 10 TIOB pin | 19 | 16 |
| | TIOB10_1 | | 105 | - |
| Base Timer 11 | TIOA11_0 | Base Timer ch 11 \emptyset TIOA pin | 5 | 5 |
| | TIOA11_1 | | 110 | - |
| | TIOB11_0 | Base Timer ch 11 TIOB pin | 20 | 17 |
| | TIOB11_1 | | 111 | - |
| | TIOB11_2 | | 24 | - |
| Base Timer 12 | TIOA12_0 | Base Timer ch 12 TIOA pin | 6 | 6 |
| | TIOA12_1 | | 112 | - |
| | TIOA12_2 | | 25 | - |
| | TIOB12_0 | Base Timer ch 12 TIOB pin | 21 | 18 |
| | TIOB12_1 | | 113 | - |
| TIOB12_2 | 41 | - | | |
| Base Timer 13 | TIOA13_0 | Base Timer ch 13 TIOA pin | 7 | 7 |
| | TIOA13_1 | | 124 | 100 |
| | TIOA13_2 | | 42 | - |
| | TIOB13_0 | Base Timer ch 13 TIOB pin | 22 | 19 |
| | TIOB13_1 | | 125 | 101 |
| | TIOB13_2 | | 43 | - |
| Base Timer 14 | TIOA14_0 | Base Timer ch 14 TIOA pin | 151 | 121 |
| | TIOA14_1 | | 82 | - |
| | TIOB14_0 | Base Timer ch 14 TIOB pin | 150 | 120 |
| | TIOB14_1 | | 83 | - |

| Module | Pin Name | Function | Pin Number | |
|---------------|----------------------------|---|------------|----------|
| | | | LQFP 176 | LQFP 144 |
| Base Timer 15 | TIOA15_0 | Base Timer ch 15 TIOA pin | 155 | 125 |
| | TIOA15_1 | | 58 | - |
| | TIOB15_0 | Base timer ch 15 TIOB pin | 154 | 124 |
| | TIOB15_1 | | 59 | - |
| CAN 0 | TX0_0 | CAN interface ch 0 TX output pin | 101 | 85 |
| | TX0_1 | | 25 | - |
| | TX0_2 | | 59 | - |
| | RX0_0 | CAN interface ch 0 RX output pin | 100 | 84 |
| | RX0_1 | | 24 | - |
| | RX0_2 | | 58 | - |
| Debugger | SWCLK | Serial wire debug interface clock input pin | 135 | 111 |
| | SWDIO | Serial wire debug interface data input/output pin | 137 | 113 |
| | SWO | Serial wire viewer output pin | 138 | 114 |
| | TCK | J-TAG test clock input pin | 135 | 111 |
| | TDI | J-TAG test data input pin | 136 | 112 |
| | TDO | J-TAG debug data output pin | 138 | 114 |
| | TMS | J-TAG test mode state input/output pin | 137 | 113 |
| | TRACECLK | Trace CLK output pin of ETM/HTM | 114 | 90 |
| | TRACED0 | Trace data output pin of ETM/ Trace data output pin of HTM | 98 | 82 |
| | TRACED1 | | 99 | 83 |
| | TRACED2 | | 100 | 84 |
| | TRACED3 | | 101 | 85 |
| | TRACED4 | Trace data output pin of HTM | 106 | 86 |
| | TRACED5 | | 107 | 87 |
| | TRACED6 | | 108 | 88 |
| | TRACED7 | | 109 | 89 |
| | TRACED8 | | 102 | - |
| | TRACED9 | | 103 | - |
| | TRACED10 | | 104 | - |
| | TRACED11 | | 105 | - |
| | TRACED12 | | 110 | - |
| | TRACED13 | | 111 | - |
| | TRACED14 | | 112 | - |
| TRACED15 | 113 | | - | |
| TRSTX | J-TAG test reset Input pin | 134 | 110 | |

| Module | Pin Name | Function | Pin Number | |
|--------------|------------|--|------------|----------|
| | | | LQFP 176 | LQFP 144 |
| External bus | MAD00_0 | External bus interface address bus | 69 | 59 |
| | MAD01_0 | | 70 | 60 |
| | MAD02_0 | | 71 | 61 |
| | MAD03_0 | | 72 | 62 |
| | MAD04_0 | | 73 | 63 |
| | MAD05_0 | | 74 | 64 |
| | MAD06_0 | | 75 | 65 |
| | MAD07_0 | | 76 | 66 |
| | MAD08_0 | | 77 | 67 |
| | MAD09_0 | | 115 | 91 |
| | MAD10_0 | | 116 | 92 |
| | MAD11_0 | | 117 | 93 |
| | MAD12_0 | | 118 | 94 |
| | MAD13_0 | | 119 | 95 |
| | MAD14_0 | | 120 | 96 |
| | MAD15_0 | | 121 | 97 |
| | MAD16_0 | | 122 | 98 |
| | MAD17_0 | | 123 | 99 |
| | MAD18_0 | | 124 | 100 |
| | MAD19_0 | | 40 | 35 |
| | MAD20_0 | | 39 | 34 |
| | MAD21_0 | | 38 | 33 |
| | MAD22_0 | | 37 | 32 |
| | MAD23_0 | | 36 | 31 |
| MAD24_0 | 35 | 30 | | |
| External bus | MCSX0_0 | External bus interface chip select output pin | 67 | 57 |
| | MCSX1_0 | | 66 | 56 |
| | MCSX2_0 | | 51 | 43 |
| | MCSX3_0 | | 50 | 42 |
| | MCSX4_0 | | 49 | 41 |
| | MCSX5_0 | | 48 | 40 |
| | MCSX6_0 | | 47 | 39 |
| | MCSX7_0 | | 46 | 38 |
| | MCSX8_0 | | 63 | 53 |
| External bus | MADATA00_0 | External bus interface data bus (address/data multiplex bus) | 2 | 2 |
| | MADATA01_0 | | 3 | 3 |
| | MADATA02_0 | | 4 | 4 |
| | MADATA03_0 | | 5 | 5 |
| | MADATA04_0 | | 6 | 6 |
| | MADATA05_0 | | 7 | 7 |

| Module | Pin Name | Function | Pin Number | |
|--------------------|------------|---|------------|----------|
| | | | LQFP 176 | LQFP 144 |
| | MADATA06_0 | | 8 | 8 |
| | MADATA07_0 | | 9 | 9 |
| | MADATA08_0 | | 13 | 10 |
| | MADATA09_0 | | 14 | 11 |
| | MADATA10_0 | | 15 | 12 |
| | MADATA11_0 | | 16 | 13 |
| | MADATA12_0 | | 17 | 14 |
| | MADATA13_0 | | 18 | 15 |
| | MADATA14_0 | | 19 | 16 |
| | MADATA15_0 | | 20 | 17 |
| | MDQM0_0 | External bus interface byte mask signal output pin | 21 | 18 |
| | MDQM1_0 | | 22 | 19 |
| | MALE_0 | External bus interface address latch enable output signal for multiplex | 171 | 139 |
| | MRDY_0 | External bus interface external RDY input signal | 68 | 58 |
| | MCLKOUT_0 | External bus interface external clock output pin | 23 | 20 |
| | MNALE_0 | External bus interface ALE signal to control NAND flash output pin | 97 | 81 |
| | MNCLE_0 | External bus interface CLE signal to control NAND flash output pin | 96 | 80 |
| | MNREX_0 | External bus interface read enable signal to control NAND flash | 94 | 78 |
| | MNWEX_0 | External bus interface write enable signal to control NAND flash | 95 | 79 |
| | MOEX_0 | External bus interface read enable signal for SRAM | 169 | 137 |
| | MWEX_0 | External bus interface write enable signal for SRAM | 170 | 138 |
| | MSDCLK_0 | SDRAM interface SDRAM clock output pin | 65 | 55 |
| | MSDCKE_0 | SDRAM interface SDRAM clock enable pin | 64 | 54 |
| | MRASX_0 | SDRAM interface SDRAM column active strobe pin | 60 | 50 |
| | MCASX_0 | SDRAM interface SDRAM row active strobe pin | 61 | 51 |
| | MSDWEX_0 | SDRAM interface SDRAM write enable pin | 62 | 52 |
| External interrupt | INT00_0 | External interrupt request 00 input pin | 2 | 2 |
| | INT00_1 | | 28 | 23 |
| | INT00_2 | | 8 | 8 |
| | INT01_0 | External interrupt request 01 input pin | 7 | 7 |
| | INT01_1 | | 31 | 26 |
| | INT01_2 | | 24 | - |
| | INT02_0 | External interrupt request 02 input pin | 13 | 10 |
| | INT02_1 | | 32 | 27 |
| | INT02_2 | | 9 | 9 |

| Module | Pin Name | Function | Pin Number | |
|--------|----------|---|-------------|-------------|
| | | | LQFP 176 | LQFP 144 |
| | INT03_0 | External interrupt request 03 input pin | 16 | 13 |
| | INT03_1 | | 33 | 28 |
| | INT03_2 | | 41 | - |
| | INT04_0 | External interrupt request 04 input pin | 49 | 41 |
| | INT04_1 | | 68 | 58 |
| | INT04_2 | | 63 | 53 |
| | INT05_0 | External interrupt request 05 input pin | 66 | 56 |
| | INT05_1 | | 79 | - |
| | INT05_2 | | 64 | 54 |
| | INT06_0 | External interrupt request 06 input pin | 60 | 50 |
| | INT06_1 | | 80 | - |
| | INT06_2 | | 69 | 59 |
| | INT07_0 | External interrupt request 07 input pin | 65 | 55 |
| | INT07_1 | | 81 | - |
| | INT07_2 | | 77 | 67 |
| | INT08_0 | External interrupt request 08 input pin | 94 | 78 |
| | INT08_1 | | 103 | - |
| | INT08_2 | | 118 | 94 |
| | INT09_0 | External interrupt request 09 input pin | 100 | 84 |
| | INT09_1 | | 104 | - |
| | INT09_2 | | 119 | 95 |
| | INT10_0 | External interrupt request 10 input pin | 106 | 86 |
| | INT10_1 | | 110 | - |
| | INT10_2 | | 120 | 96 |
| | INT11_0 | External interrupt request 11 input pin | 109 | 89 |
| | INT11_1 | | 111 | - |
| | INT11_2 | | 122 | 98 |
| | INT12_0 | External interrupt request 12 input pin | 162 | 132 |
| | INT12_1 | | 139 | - |
| | INT13_0 | External interrupt request 13 input pin | 152 | 122 |
| | INT13_1 | | 140 | - |

| Module | Pin Name | Function | Pin Number | |
|--------------------|---|---|-------------|-------------|
| | | | LQFP 176 | LQFP 144 |
| External interrupt | INT14_0 | External interrupt request 14 input pin | 160 | 130 |
| | INT14_1 | | 141 | - |
| | INT15_0 | External interrupt request 15 input pin | 161 | 131 |
| | INT15_1 | | 142 | - |
| | INT16_0 | External interrupt request 16 input pin | 20 | 17 |
| | INT16_1 | | 35 | 30 |
| | INT17_0 | External interrupt request 17 input pin | 21 | 18 |
| | INT17_1 | | 36 | 31 |
| | INT18_0 | External interrupt request 18 input pin | 22 | 19 |
| | INT18_1 | | 37 | 32 |
| | INT19_0 | External interrupt request 19 input pin | 26 | 21 |
| | INT19_1 | | 38 | 33 |
| | INT20_0 | External interrupt request 20 input pin | 70 | 60 |
| | INT20_1 | | 82 | - |
| | INT21_0 | External interrupt request 21 input pin | 73 | 63 |
| | INT21_1 | | 83 | - |
| | INT22_0 | External interrupt request 22 input pin | 76 | 66 |
| | INT22_1 | | 58 | - |
| | INT23_0 | External interrupt request 23 input pin | 46 | 38 |
| | INT23_1 | | 59 | - |
| | INT24_0 | External interrupt request 24 input pin | 121 | 97 |
| | INT24_1 | | 107 | 87 |
| | INT25_0 | External interrupt request 25 input pin | 123 | 99 |
| | INT25_1 | | 97 | 81 |
| | INT26_0 | External interrupt request 26 input pin | 126 | 102 |
| | INT26_1 | | 116 | 92 |
| | INT27_0 | External interrupt request 27 input pin | 127 | 103 |
| | INT27_1 | | 117 | 93 |
| | INT28_0 | External interrupt request 28 input pin | 158 | 128 |
| | INT28_1 | | 167 | - |
| | INT29_0 | External interrupt request 29 input pin | 166 | 136 |
| | INT29_1 | | 168 | - |
| | INT30_0 | External interrupt request 30 input pin | 169 | 137 |
| | INT30_1 | | 163 | 133 |
| INT31_0 | External interrupt request 31 input pin | 172 | 140 | |
| INT31_1 | | 164 | 134 | |
| NMIX | Non-maskable interrupt input pin | 128 | 104 | |

| Module | Pin Name | Function | Pin Number | |
|--------|----------|----------------------------|-------------|-------------|
| | | | LQFP 176 | LQFP 144 |
| GPIO | P00 | General-purpose I/O port 0 | 134 | 110 |
| | P01 | | 135 | 111 |
| | P02 | | 136 | 112 |
| | P03 | | 137 | 113 |
| | P04 | | 138 | 114 |
| | P08 | | 21 | 18 |
| | P09 | | 22 | 19 |
| | P0A | | 23 | 20 |
| | P10 | General-purpose I/O port 1 | 94 | 78 |
| | P11 | | 95 | 79 |
| | P12 | | 96 | 80 |
| | P13 | | 97 | 81 |
| | P14 | | 98 | 82 |
| | P15 | | 99 | 83 |
| | P16 | | 100 | 84 |
| | P17 | | 101 | 85 |
| | P18 | | 106 | 86 |
| | P19 | | 107 | 87 |
| | P1A | | 108 | 88 |
| | P1B | | 109 | 89 |
| | P1C | 114 | 90 | |
| | P1D | 115 | 91 | |
| | P1E | 116 | 92 | |
| | P1F | 117 | 93 | |
| | P20 | General-purpose I/O port 2 | 128 | 104 |
| | P21 | | 127 | 103 |
| | P22 | | 126 | 102 |
| | P23 | | 125 | 101 |
| | P24 | | 124 | 100 |
| | P25 | | 123 | 99 |
| P26 | 122 | | 98 | |
| P27 | 121 | | 97 | |
| P28 | 120 | | 96 | |
| P29 | 119 | | 95 | |
| P2A | 118 | 94 | | |

| Module | Pin Name | Function | Pin Number | |
|--------|----------|----------------------------|-------------|-------------|
| | | | LQFP 176 | LQFP 144 |
| GPIO | P30 | General-purpose I/O port 3 | 24 | - |
| | P31 | | 25 | - |
| | P32 | | 26 | 21 |
| | P33 | | 27 | 22 |
| | P34 | | 28 | 23 |
| | P35 | | 31 | 26 |
| | P36 | | 32 | 27 |
| | P37 | | 33 | 28 |
| | P38 | | 34 | 29 |
| | P39 | | 35 | 30 |
| | P3A | | 36 | 31 |
| | P3B | | 37 | 32 |
| | P3C | | 38 | 33 |
| | P3D | | 39 | 34 |
| | P3E | | 40 | 35 |
| | P40 | General-purpose I/O port 4 | 46 | 38 |
| | P41 | | 47 | 39 |
| | P42 | | 48 | 40 |
| | P43 | | 49 | 41 |
| | P44 | | 50 | 42 |
| | P45 | | 51 | 43 |
| | P46 | | 55 | 47 |
| | P47 | | 56 | 48 |
| | P48 | | 60 | 50 |
| | P49 | | 61 | 51 |
| | P4A | | 62 | 52 |
| | P4B | | 63 | 53 |
| | P4C | | 64 | 54 |
| | P4D | | 65 | 55 |
| | P4E | | 66 | 56 |

| Module | Pin Name | Function | Pin Number | |
|--------|----------|----------------------------|-------------|-------------|
| | | | LQFP 176 | LQFP 144 |
| GPIO | P50 | General-purpose I/O port 5 | 10 | - |
| | P51 | | 11 | - |
| | P52 | | 12 | - |
| | P5D | | 41 | - |
| | P5E | | 42 | - |
| | P5F | | 43 | - |
| | P60 | General-purpose I/O port 6 | 172 | 140 |
| | P61 | | 171 | 139 |
| | P62 | | 170 | 138 |
| | P63 | | 169 | 137 |
| | P64 | | 168 | - |
| | P65 | | 167 | - |
| | P6E | | 166 | 136 |

| Module | Pin Name | Function | Pin Number | |
|--------|----------|----------------------------|-------------|-------------|
| | | | LQFP 176 | LQFP 144 |
| GPIO | P70 | General-purpose I/O port 7 | 67 | 57 |
| | P71 | | 68 | 58 |
| | P72 | | 69 | 59 |
| | P73 | | 70 | 60 |
| | P74 | | 71 | 61 |
| | P75 | | 72 | 62 |
| | P76 | | 73 | 63 |
| | P77 | | 74 | 64 |
| | P78 | | 75 | 65 |
| | P79 | | 76 | 66 |
| | P7A | | 77 | 67 |
| | P80 | General-purpose I/O port 8 | 174 | 142 |
| | P81 | | 175 | 143 |
| | P82 | | 130 | 106 |
| | P83 | | 131 | 107 |
| | P90 | General-purpose I/O port 9 | 139 | - |
| | P91 | | 140 | - |
| | P92 | | 141 | - |
| | P93 | | 142 | - |
| | P94 | | 143 | - |
| | P95 | | 144 | - |
| | PA0 | General-purpose I/O port A | 2 | 2 |
| | PA1 | | 3 | 3 |
| | PA2 | | 4 | 4 |
| | PA3 | | 5 | 5 |
| | PA4 | | 6 | 6 |
| | PA5 | | 7 | 7 |
| | PA6 | | 8 | 8 |
| | PA7 | | 9 | 9 |
| | PA8 | | 13 | 10 |
| | PA9 | | 14 | 11 |
| | PAA | | 15 | 12 |
| PAB | 16 | | 13 | |
| PAC | 17 | | 14 | |
| PAD | 18 | | 15 | |
| PAE | 19 | | 16 | |
| PAF | 20 | 17 | | |

| Module | Pin Name | Function | Pin Number | |
|--------|----------|----------------------------|-------------|-------------|
| | | | LQFP 176 | LQFP 144 |
| GPIO | PB0 | General-purpose I/O port B | 102 | - |
| | PB1 | | 103 | - |
| | PB2 | | 104 | - |
| | PB3 | | 105 | - |
| | PB4 | | 110 | - |
| | PB5 | | 111 | - |
| | PB6 | | 112 | - |
| | PB7 | | 113 | - |
| | PC0 | General-purpose I/O port C | 145 | 115 |
| | PC1 | | 146 | 116 |
| | PC2 | | 147 | 117 |
| | PC3 | | 148 | 118 |
| | PC4 | | 149 | 119 |
| | PC5 | | 150 | 120 |
| | PC6 | | 151 | 121 |
| | PC7 | | 152 | 122 |
| | PC8 | | 153 | 123 |
| | PC9 | | 154 | 124 |
| | PCA | | 155 | 125 |
| | PCB | | 158 | 128 |
| | PCC | | 159 | 129 |
| | PCD | | 160 | 130 |
| | PCE | | 161 | 131 |
| | PCF | 162 | 132 | |
| | PD0 | General-purpose I/O port D | 163 | 133 |
| | PD1 | | 164 | 134 |
| | PD2 | | 165 | 135 |
| | PE0 | General-purpose I/O port E | 84 | 68 |
| | PE2 | | 86 | 70 |
| | PE3 | | 87 | 71 |
| | PF0 | General-purpose I/O port F | 58 | - |
| | PF1 | | 59 | - |
| PF2 | 78 | | - | |
| PF3 | 79 | | - | |
| PF4 | 80 | | - | |
| PF5 | 81 | | - | |
| PF6 | 82 | | - | |
| PF7 | 83 | | - | |

| Module | Pin Name | Function | Pin Number | |
|-------------------------|-----------------------------------|--|-------------|-------------|
| | | | LQFP 176 | LQFP 144 |
| Multi-Function Serial 0 | SIN0_0 | Multi-function serial interface ch 0 input pin | 127 | 103 |
| | SIN0_1 | | 116 | 92 |
| | SOT0_0 (SDA0_0) | Multi-function serial interface ch 0 output pin This pin operates as SOT0 when it is used in a UART/CSIO/LIN (operation modes 0 to 3) and as SDA0 when it is used in an I ² C (operation mode 4). | 126 | 102 |
| | SOT0_1 (SDA0_1) | | 115 | 91 |
| | SCK0_0 (SCL0_0) | Multi-function serial interface ch 0 clock I/O pin This pin operates as SCK0 when it is used in a CSIO (operation mode 2) and as SCL0 when it is used in an I ² C (operation mode 4) | 125 | 101 |
| | SCK0_1 (SCL0_1) | | 114 | 90 |
| Multi-Function Serial 1 | SIN1_0 (MI2SDI1_0) | Multi-function serial interface ch 1 input pin. | 60 | 50 |
| | SIN1_1 (MI2SDI1_1) | SIN1 pin operates as MI2SDI1 when used as an I ² S pin (operation mode 2). | 41 | - |
| | SOT1_0 (SDA1_0) (MI2SDO1_0) | Multi-function serial interface ch 1 output pin This pin operates as SOT1 when it is used in a UART/CSIO/LIN (operation modes 0 to 3) and as SDA1 when it is used in an I ² C (operation mode 4). SOT1 pin operates as MI2SDO1 when used as an I ² S pin (operation mode 2). | 61 | 51 |
| | SOT1_1 (SDA1_1) (MI2SDO1_1) | | 42 | - |
| | SCK1_0 (SCL1_0) (MI2SCK1_0) | Multi-function serial interface ch 1 clock I/O pin This pin operates as SCK1 when it is used in a CSIO (operation mode 2) and as SCL1 when it is used in an I ² C (operation mode 4). SCK1 pin operates as MI2SCK1 when used as an I ² S pin (operation mode 2). | 62 | 52 |
| | SCK1_1 (SCL1_1) (MI2SCK1_1) | | 43 | - |
| | MI2SWS1_0 | I ² S word select (WS) output pin | 63 | 53 |
| | MI2SWS1_1 | | 24 | - |
| | MI2SMCK1_0 | I ² S master clock I/O pin | 64 | 54 |
| | MI2SMCK1_1 | | 25 | - |

| Module | Pin Name | Function | Pin Number | |
|-------------------------|-----------------|--|-------------|-------------|
| | | | LQFP 176 | LQFP 144 |
| Multi-Function Serial 2 | SIN2_0 | Multi-function serial interface ch 2 input pin | 106 | 86 |
| | SIN2_1 | | 38 | 33 |
| | SOT2_0 (SDA2_0) | Multi-function serial interface ch 2 output pin | 107 | 87 |
| | SOT2_1 (SDA2_1) | This pin operates as SOT2 when it is used in a UART/CSIO/LIN (operation modes 0 to 3) and as SDA2 when it is used in an I ² C (operation mode 4). | 39 | 34 |
| | SCK2_0 (SCL2_0) | Multi-function serial interface ch 2 clock I/O pin | 108 | 88 |
| | SCK2_1 (SCL2_1) | This pin operates as SCK2 when it is used in a CSIO (operation mode 2) and as SCL2 when it is used in an I ² C (operation mode 4). | 40 | 35 |
| Multi-Function Serial 3 | SIN3_0 | Multi-function serial interface ch 3 input pin | 20 | 17 |
| | SIN3_1 | | 81 | - |
| | SOT3_0 (SDA3_0) | Multi-function serial interface ch 3 output pin | 19 | 16 |
| | SOT3_1 (SDA3_1) | This pin operates as SOT3 when it is used in a UART/CSIO/LIN (operation modes 0 to 3) and as SDA3 when it is used in an I ² C (operation mode 4). | 82 | - |
| | SCK3_0 (SCL3_0) | Multi-function serial interface ch 3 clock I/O pin | 18 | 15 |
| | SCK3_1 (SCL3_1) | This pin operates as SCK3 when it is used in a CSIO (operation modes 2) and as SCL3 when it is used in an I ² C (operation mode 4). | 83 | - |
| Multi-Function Serial 4 | SIN4_0 | Multi-function serial interface ch 4 input pin | 172 | 140 |
| | SIN4_1 | | 161 | 131 |
| | SOT4_0 (SDA4_0) | Multi-function serial interface ch 4 output pin | 171 | 139 |
| | SOT4_1 (SDA4_1) | This pin operates as SOT4 when it is used in a UART/CSIO/LIN (operation modes 0 to 3) and as SDA4 when it is used in an I ² C (operation mode 4). | 160 | 130 |
| | SCK4_0 (SCL4_0) | Multi-function serial interface ch 4 clock I/O pin | 170 | 138 |
| | SCK4_1 (SCL4_1) | This pin operates as SCK4 when it is used in a CSIO (operation mode 2) and as SCL4 when it is used in an I ² C (operation mode 4). | 166 | 136 |
| | CTS4_0 | Multi-function serial interface ch 4 CTS input pin | 168 | - |
| | CTS4_1 | | 165 | 135 |
| | RTS4_0 | Multi-function serial interface ch 4 RTS output pin | 169 | 137 |
| | RTS4_1 | | 162 | 132 |

| Module | Pin Name | Function | Pin Number | |
|----------------------------|--------------------|---|-------------|-------------|
| | | | LQFP 176 | LQFP 144 |
| Multi-Function Serial 5 | SIN5_0 | Multi-function serial interface ch 5 input pin | 121 | 97 |
| | SIN5_1 | | 140 | - |
| | SOT5_0 (SDA5_0) | Multi-function serial interface ch 5 output pin This pin operates as SOT5 when it is used in a UART/CSIO/LIN (operation modes 0 to 3) and as SDA5 when it is used in an I ² C (operation mode 4). | 120 | 96 |
| | SOT5_1 (SDA5_1) | | 141 | - |
| | SCK5_0 (SCL5_0) | Multi-function serial interface ch 5 clock I/O pin This pin operates as SCK5 when it is used in a CSIO (operation mode 2) and as SCL5 when it is used in an I ² C (operation mode 4). | 119 | 95 |
| | SCK5_1 (SCL5_1) | | 142 | - |
| | CTS5_0 | Multi-function serial interface ch 5 CTS input pin | 118 | 94 |
| | CTS5_1 | | 143 | - |
| | RTS5_0 | Multi-function serial interface ch 5 RTS output pin | 117 | 93 |
| | RTS5_1 | | 144 | - |
| Multi-Function Serial 6 | SIN6_0 | Multi-function serial interface ch 6 input pin | 73 | 63 |
| | SIN6_1 | | 100 | 84 |
| | SOT6_0 (SDA6_0) | Multi-function serial interface ch 6 output pin This pin operates as SOT6 when it is used in a UART/CSIO/LIN (operation modes 0 to 3) and as SDA6 when it is used in an I ² C (operation mode 4). | 74 | 64 |
| | SOT6_1 (SDA6_1) | | 101 | 85 |
| | SCK6_0 (SCL6_0) | Multi-function serial interface ch 6 clock I/O pin This pin operates as SCK6 when it is used in a CSIO (operation mode 2) and as SCL6 when it is used in an I ² C (operation mode 4). | 75 | 65 |
| | SCK6_1 (SCL6_1) | | 102 | - |
| | SCS60_0 | Multi-function serial interface ch 6 chip select 0 input/output pin | 76 | 66 |
| | SCS60_1 | | 103 | - |
| | SCS61_0 | Multi-function serial interface ch 6 chip select1 input/output pin | 77 | 67 |
| | SCS61_1 | | 104 | - |
| | SCS62_0 | Multi-function serial interface ch 6 chip select2 input/output pin | 78 | - |
| | SCS62_1 | | 105 | - |
| | SCS63_0 | Multi-function serial interface ch 6 chip select3 input/output pin | 79 | - |
| SCS63_1 | 110 | | - | |

| Module | Pin Name | Function | Pin Number | |
|-------------------------|-----------------|---|-------------|-------------|
| | | | LQFP 176 | LQFP 144 |
| Multi-Function Serial 7 | SIN7_0 | Multi-function serial interface ch 7 input pin | 13 | 10 |
| | SIN7_1 | | 46 | 38 |
| | SOT7_0 (SDA7_0) | Multi-function serial interface ch 7 output pin This pin operates as SOT7 when it is used in a UART/CSIO/LIN (operation modes 0 to 3) and as SDA7 when it is used in an I ² C (operation mode 4). | 14 | 11 |
| | SOT7_1 (SDA7_1) | | 47 | 39 |
| | SCK7_0 (SCL7_0) | Multi-function serial interface ch 7 clock I/O pin This pin operates as SCK7 when it is used in a CSIO (operation mode 2) and as SCL7 when it is used in an I ² C (operation mode 4). | 15 | 12 |
| | SCK7_1 (SCL7_1) | | 48 | 40 |
| | SCS70_0 | Multi-function serial interface ch 7 chip select 0 input/output pin | 16 | 13 |
| | SCS70_1 | | 49 | 41 |
| | SCS71_0 | Multi-function serial interface ch 7 chip select 1 input/output pin | 17 | 14 |
| | SCS71_1 | | 50 | 42 |
| | SCS72_0 | Multi-function serial interface ch 7 chip select 2 input/output pin | 10 | - |
| | SCS72_1 | | 51 | 43 |
| | SCS73_0 | Multi-function serial interface ch 7 chip select 3 input/output pin | 11 | - |
| | SCS73_1 | | 58 | - |
| Multi-Function Serial 8 | SIN8_0 | Multi-function serial interface ch 8 input pin | 70 | 60 |
| | SIN8_1 | | 111 | - |
| | SOT8_0 (SDA8_0) | Multi-function serial interface ch 8 output pin This pin operates as SOT8 when it is used in a UART/CSIO/LIN (operation modes 0 to 3) and as SDA8 when it is used in an I ² C (operation mode 4). | 71 | 61 |
| | SOT8_1 (SDA8_1) | | 112 | - |
| | SCK8_0 (SCL8_0) | Multi-function serial interface ch 8 clock I/O pin This pin operates as SCK8 when it is used in a CSIO (operation mode 2) and as SCL8 when it is used in an I ² C (operation mode 4). | 72 | 62 |
| | SCK8_1 (SCL8_1) | | 113 | - |
| Multi-Function Serial 9 | SIN9_0 | Multi-function serial interface ch 9 input pin | 68 | 58 |
| | SIN9_1 | | 97 | 81 |
| | SOT9_0 (SDA9_0) | Multi-function serial interface ch 9 output pin This pin operates as SOT9 when it is used in a UART/CSIO/LIN (operation modes 0 to 3) and as SDA9 when it is used in an I ² C (operation mode 4). | 67 | 57 |
| | SOT9_1 (SDA9_1) | | 98 | 82 |
| | SCK9_0 (SCL9_0) | Multi-function serial interface ch 9 clock I/O pin This pin operates as SCK9 when it is used in a CSIO (operation mode 2) and as SCL9 when it is used in an I ² C (operation mode 4). | 66 | 56 |
| | SCK9_1 (SCL9_1) | | 99 | 83 |

| Module | Pin Name | Function | Pin Number | | |
|---------------------------|--|--|--|-------------|----|
| | | | LQFP 176 | LQFP 144 | |
| Multi-Function Timer 0 | DTTIOX_0 | Input signal controlling waveform generator outputs RTO00 to RTO05 of Multi-Function Timer 0. | 34 | 29 | |
| | DTTIOX_1 | | 8 | 8 | |
| | FRCK0_0 | 16-bit free-run timer ch 0 external clock input pin | 27 | 22 | |
| | FRCK0_1 | | 13 | 10 | |
| | IC00_0 | 16-bit input capture input pin of Multi-Function Timer 0. ICxx describes channel number. | 33 | 28 | |
| | IC00_1 | | 9 | 9 | |
| | IC01_0 | | 32 | 27 | |
| | IC01_1 | | 10 | - | |
| | IC02_0 | | 31 | 26 | |
| | IC02_1 | | 11 | - | |
| | IC03_0 | | 28 | 23 | |
| | IC03_1 | | 12 | - | |
| | RTO00_0 (PPG00_0) | | Waveform generator output pin of Multi-Function Timer 0. This pin operates as PPG00 when it is used in PPG0 output modes. | 35 | 30 |
| | RTO00_1 (PPG00_1) | | | 2 | 2 |
| | RTO01_0 (PPG00_0) | Waveform generator output pin of Multi-Function Timer 0. This pin operates as PPG00 when it is used in PPG0 output modes. | 36 | 31 | |
| | RTO01_1 (PPG00_1) | | 3 | 3 | |
| | RTO02_0 (PPG02_0) | Waveform generator output pin of Multi-Function Timer 0. This pin operates as PPG02 when it is used in PPG0 output modes. | 37 | 32 | |
| | RTO02_1 (PPG02_1) | | 4 | 4 | |
| | RTO03_0 (PPG02_0) | Waveform generator output pin of Multi-Function Timer 0. This pin operates as PPG02 when it is used in PPG0 output modes. | 38 | 33 | |
| | RTO03_1 (PPG02_1) | | 5 | 5 | |
| RTO04_0 (PPG04_0) | Waveform generator output pin of Multi-Function Timer 0. This pin operates as PPG04 when it is used in PPG0 output modes. | 39 | 34 | | |
| RTO04_1 (PPG04_1) | | 6 | 6 | | |
| RTO05_0 (PPG04_0) | Waveform generator output pin of Multi-Function Timer 0. This pin operates as PPG04 when it is used in PPG0 output modes. | 40 | 35 | | |
| RTO05_1 (PPG04_1) | | 7 | 7 | | |

| Module | Pin Name | Function | Pin Number | | |
|---------------------------|----------------------|--|--|-------------|----|
| | | | LQFP 176 | LQFP 144 | |
| Multi-Function Timer 1 | DTTI1X_0 | Input signal controlling waveform generator outputs RTO10 to RTO15 of Multi-Function Timer 1. | 60 | 50 | |
| | DTTI1X_1 | | 78 | - | |
| | FRCK1_0 | 16-bit free-run timer ch 1 external clock input pin | 65 | 55 | |
| | FRCK1_1 | | 79 | - | |
| | IC10_0 | 16-bit input capture input pin of Multi-Function Timer 1. ICxx describes channel number. | 61 | 51 | |
| | IC10_1 | | 80 | - | |
| | IC11_0 | | 62 | 52 | |
| | IC11_1 | | 81 | - | |
| | IC12_0 | | 63 | 53 | |
| | IC12_1 | | 82 | - | |
| | IC13_0 | | 64 | 54 | |
| | IC13_1 | | 83 | - | |
| | RTO10_0 (PPG10_0) | | Waveform generator output pin of Multi-Function Timer 1. This pin operates as PPG10 when it is used in PPG1 output modes. | 46 | 38 |
| | RTO10_1 (PPG10_1) | | | 139 | - |
| | RTO11_0 (PPG10_0) | Waveform generator output pin of Multi-Function Timer 1. This pin operates as PPG10 when it is used in PPG1 output modes. | 47 | 39 | |
| | RTO11_1 (PPG10_1) | | 140 | - | |
| | RTO12_0 (PPG12_0) | Waveform generator output pin of Multi-Function Timer 1. This pin operates as PPG12 when it is used in PPG1 output modes. | 48 | 40 | |
| | RTO12_1 (PPG12_1) | | 141 | - | |
| | RTO13_0 (PPG12_0) | Waveform generator output pin of Multi-Function Timer 1. This pin operates as PPG12 when it is used in PPG1 output modes. | 49 | 41 | |
| | RTO13_1 (PPG12_1) | | 142 | - | |
| | RTO14_0 (PPG14_0) | Waveform generator output pin of Multi-Function Timer 1. This pin operates as PPG14 when it is used in PPG1 output modes. | 50 | 42 | |
| | RTO14_1 (PPG14_1) | | 143 | - | |
| | RTO15_0 (PPG14_0) | Waveform generator output pin of Multi-Function Timer 1. This pin operates as PPG14 when it is used in PPG1 output modes. | 51 | 43 | |
| | RTO15_1 (PPG14_1) | | 144 | - | |

| Module | Pin Name | Function | Pin Number | |
|---|----------|---|------------|----------|
| | | | LQFP 176 | LQFP 144 |
| Quadrature Position/ Revolution Counter 0 | AIN0_0 | QPRC ch 0 AIN input pin | 46 | 38 |
| | AIN0_1 | | 75 | 65 |
| | AIN0_2 | | 103 | - |
| | BIN0_0 | QPRC ch 0 BIN input pin | 47 | 39 |
| | BIN0_1 | | 76 | 66 |
| | BIN0_2 | | 104 | - |
| | ZIN0_0 | QPRC ch 0 ZIN input pin | 48 | 40 |
| | ZIN0_1 | | 77 | 67 |
| | ZIN0_2 | | 105 | - |
| Quadrature Position/ Revolution Counter 1 | AIN1_0 | QPRC ch 1 AIN input pin | 35 | 30 |
| | AIN1_1 | | 14 | 11 |
| | AIN1_2 | | 111 | - |
| | BIN1_0 | QPRC ch 1 BIN input pin | 36 | 31 |
| | BIN1_1 | | 15 | 12 |
| | BIN1_2 | | 112 | - |
| | ZIN1_0 | QPRC ch 1 ZIN input pin | 37 | 32 |
| | ZIN1_1 | | 16 | 13 |
| | ZIN1_2 | | 113 | - |
| Real-time clock | RTCCO_0 | 0.5 seconds pulse output pin of real-time clock | 171 | 139 |
| | RTCCO_1 | | 9 | 9 |
| | SUBOUT_0 | Sub-clock output pin | 171 | 139 |
| | SUBOUT_1 | | 9 | 9 |
| USB0 | UDM0 | USB ch 0 function/host D – pin | 174 | 142 |
| | UDP0 | USB ch 0 function/host D + pin | 175 | 143 |
| | UHCONX0 | USB ch 0 external pull-up control pin | 171 | 139 |
| USB1 | UDM1 | USB ch 1 function/host D – pin | 130 | 106 |
| | UDP1 | USB ch 1 function/host D + pin | 131 | 107 |
| | UHCONX1 | USB ch 1 external pull-up control pin | 125 | 101 |
| Low power consumption mode | WKUP0 | Deep standby mode return signal input pin 0 | 128 | 104 |
| | WKUP1 | Deep standby mode return signal input pin 1 | 13 | 10 |
| | WKUP2 | Deep standby mode return signal input pin 2 | 66 | 56 |
| | WKUP3 | Deep standby mode return signal input pin 3 | 172 | 140 |

| Module | Pin Name | Function | Pin Number | |
|------------|---------------------------------|--|------------|----------|
| | | | LQFP 176 | LQFP 144 |
| Ethernet | E_COL | Collision detection | 154 | 124 |
| | E_COUT | Clock output for Ethernet PHY | 158 | 128 |
| | E_CRS | Carrier detection | 155 | 125 |
| | E_MDC | Management clock | 152 | 122 |
| | E_MDIO | Management data I/O | 151 | 121 |
| | E_PPS | PTP counter monitor | 166 | 136 |
| | E_RX00 | Received data0 | 149 | 119 |
| | E_RX01 | Received data1 | 148 | 118 |
| | E_RX02 | Received data2 | 147 | 117 |
| | E_RX03 | Received data3 | 146 | 116 |
| | E_RXCK_REFC K | Received clock input/ Reference clock | 153 | 123 |
| | E_RXDV | Received data enable | 150 | 120 |
| | E_RXER | Received data error detection | 145 | 115 |
| | E_TCK | Transition clock input | 159 | 129 |
| | E_TX00 | Transition data0 | 164 | 134 |
| | E_TX01 | Transition data1 | 163 | 133 |
| | E_TX02 | Transition data2 | 162 | 132 |
| | E_TX03 | Transition data3 | 161 | 131 |
| | E_TXEN | Transition data enable | 165 | 135 |
| E_TXER | Transition data error detection | 160 | 130 | |
| Smartcard0 | IC0_VCC_0 | Smartcard ch 0 power enable output pin | 6 | 6 |
| | IC0_VCC_1 | | 140 | - |
| | IC0_VPEN_0 | Smartcard ch 0 programming output pin | 5 | 5 |
| | IC0_VPEN_1 | | 141 | - |
| | IC0_RST_0 | Smartcard ch 0 reset output pin | 4 | 4 |
| | IC0_RST_1 | | 142 | - |
| | IC0_CIN_0 | Smartcard ch 0 insert detection input pin | 2 | 2 |
| | IC0_CIN_1 | | 144 | - |
| | IC0_CLK_0 | Smartcard ch 0 serial interface clock output pin | 7 | 7 |
| | IC0_CLK_1 | | 139 | - |
| | IC0_DATA_0 | Smartcard ch 0 serial interface data I/O pin | 3 | 3 |
| | IC0_DATA_1 | | 143 | - |

| Module | Pin Name | Function | Pin Number | |
|------------|------------|---|------------|----------|
| | | | LQFP 176 | LQFP 144 |
| Smartcard1 | IC1_VCC_0 | Smartcard ch 1 power enable output pin | 95 | 79 |
| | IC1_VCC_1 | | 79 | - |
| | IC1_VPEN_0 | Smartcard ch 1 programming output pin | 96 | 80 |
| | IC1_VPEN_1 | | 80 | - |
| | IC1_RST_0 | Smartcard ch 1 reset output pin | 97 | 81 |
| | IC1_RST_1 | | 81 | - |
| | IC1_CIN_0 | Smartcard ch 1 insert detection input pin | 99 | 83 |
| | IC1_CIN_1 | | 83 | - |
| | IC1_CLK_0 | Smartcard ch 1 serial interface clock output pin | 94 | 78 |
| | IC1_CLK_1 | | 78 | - |
| | IC1_DATA_0 | Smartcard ch 1 serial interface data I/O pin | 98 | 82 |
| | IC1_DATA_1 | | 82 | - |
| Reset | INITX | External reset Input pin A reset is valid when INITX = L. | 57 | 49 |
| Mode | MD1 | Mode 1 pin During serial programming to flash memory, MD1 = L must be input. | 84 | 68 |
| | MD0 | Mode 0 pin During normal operation, MD0 = L must be input. During serial programming to flash memory, MD0 = H must be input. | 85 | 69 |
| Power | VCC | Power supply pin | 1 | 1 |
| | | | 29 | 24 |
| | | | 45 | 37 |
| | | | 54 | 46 |
| | | | 89 | 73 |
| | | | 133 | 109 |
| | USBVCC0 | 3.3V power supply port for USB I/O | 173 | 141 |
| USBVCC1 | 129 | | 105 | |
| | ETHVCC | Power supply pin for Ethernet I/O | 156 | 126 |
| GND | VSS | GND pin | 30 | 25 |
| | | | 44 | 36 |
| | | | 53 | 45 |
| | | | 88 | 72 |
| | | | 132 | 108 |
| | | | 157 | 127 |
| | | | 176 | 144 |
| Clock | X0 | Main clock (oscillation) input pin | 86 | 70 |
| | X1 | Main clock (oscillation) I/O pin | 87 | 71 |
| | X0A | Sub clock (oscillation) input pin | 55 | 47 |
| | X1A | Sub clock (oscillation) I/O pin | 56 | 48 |
| | CROUT_0 | Built-in high-speed CR-oscillation clock output port | 127 | 103 |
| | CROUT_1 | | 152 | 122 |

| Module | Pin Name | Function | Pin Number | |
|-----------------|----------|--|-------------|-------------|
| | | | LQFP 176 | LQFP 144 |
| Analog power | AVCC | A/D converter and D/A converter analog power-supply pin | 90 | 74 |
| | AVRL | A/D converter analog reference voltage input pin | 92 | 76 |
| | AVRH | A/D converter analog reference voltage input pin | 93 | 77 |
| Analog GND | AVSS | A/D converter and D/A converter GND pin | 91 | 75 |
| C pin | C | Power supply stabilization capacity pin | 52 | 44 |

5. I/O Circuit Type

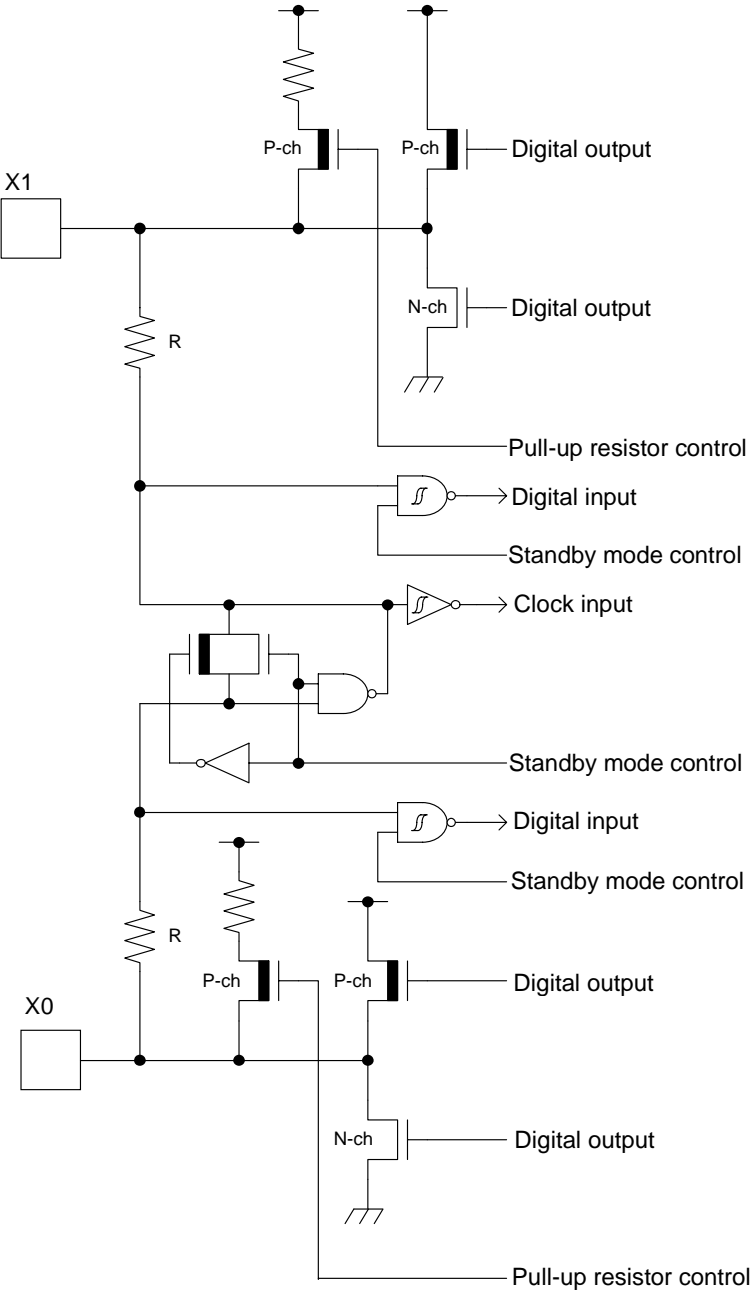
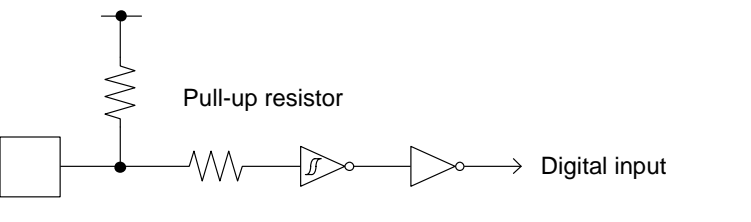
| Type | Circuit | Remarks |
|------|---|---|
| A |  | <p>It is possible to select the main oscillation/GPIO function.</p> <p>When the main oscillation is selected:</p> <ul style="list-style-type: none"> • Oscillation feedback resistor: approximately 1 MΩ • Standby mode control <p>When the GPIO is selected:</p> <ul style="list-style-type: none"> • CMOS level output. • CMOS level hysteresis input • Pull-up resistor control • Standby mode control • Pull-up resistor: approximately 50 kΩ • $I_{OH} = -4 \text{ mA}$, $I_{OL} = 4 \text{ mA}$ |
| B |  | <ul style="list-style-type: none"> • CMOS level hysteresis input • Pull-up resistor: approximately 50 kΩ |

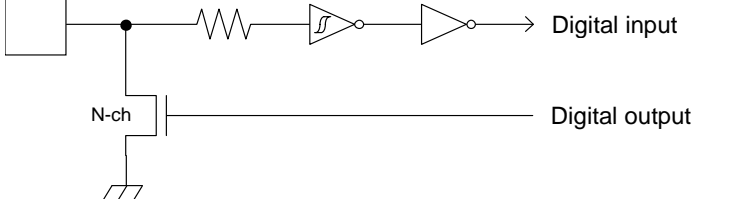
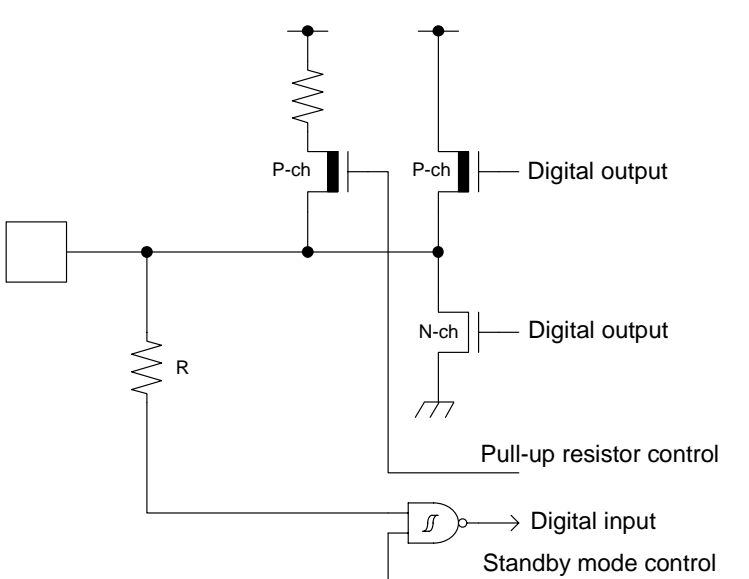
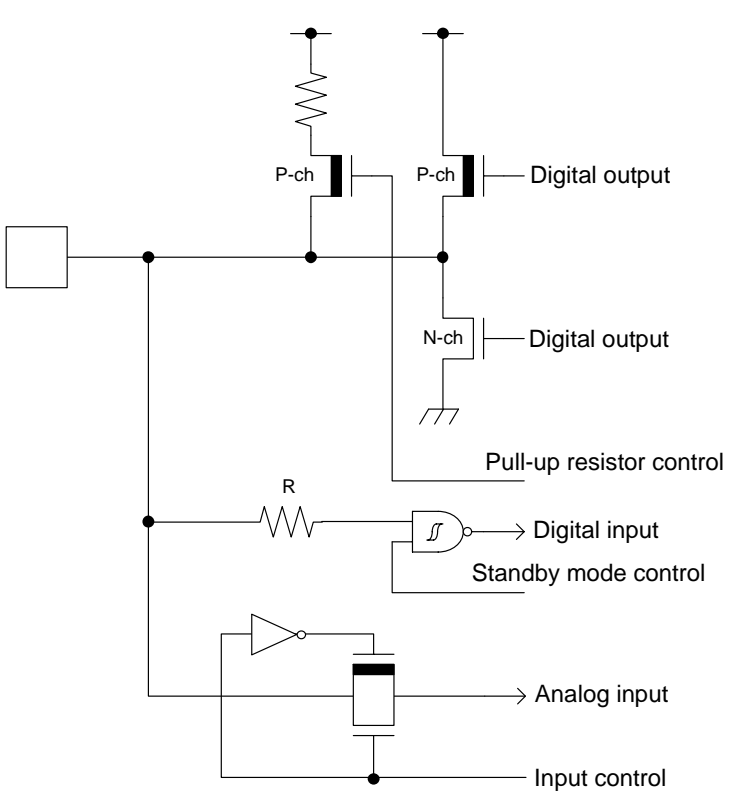
| Type | Circuit | Remarks |
|------|---|--|
| C |  | <ul style="list-style-type: none"> • Open drain output • CMOS level hysteresis input |
| E |  | <ul style="list-style-type: none"> • CMOS level output • CMOS level hysteresis input • Pull-up resistor control • Standby mode control • Pull-up resistor: approximately 50 kΩ • $I_{OH} = -4 \text{ mA}$, $I_{OL} = 4 \text{ mA}$ • When this pin is used as an I²C pin, the digital output P-ch transistor is always off. |
| F |  | <ul style="list-style-type: none"> • CMOS level output • CMOS level hysteresis input • Input control • Analog input • Pull-up resistor control • Standby mode control • Pull-up resistor: approximately 50 kΩ • $I_{OH} = -4 \text{ mA}$, $I_{OL} = 4 \text{ mA}$ • When this pin is used as an I²C pin, the digital output P-ch transistor is always off. |

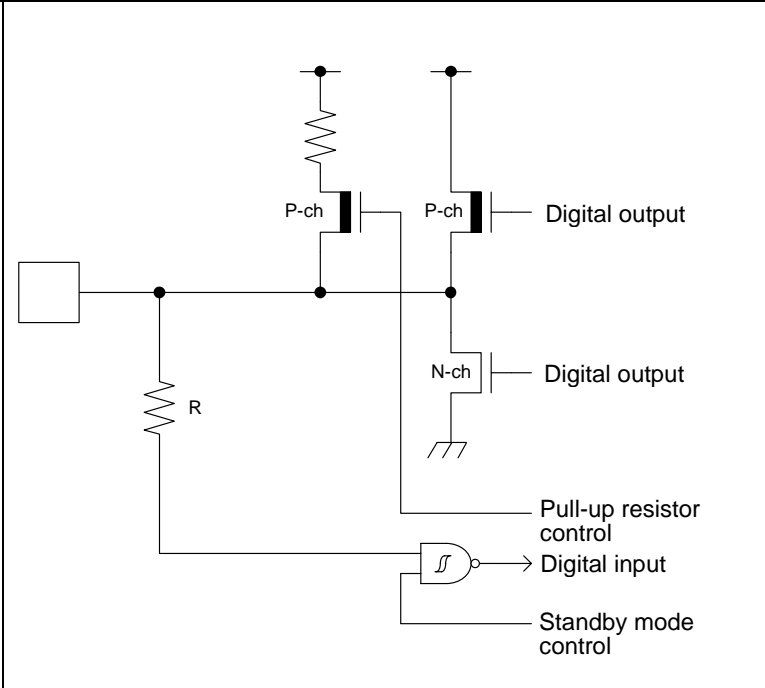
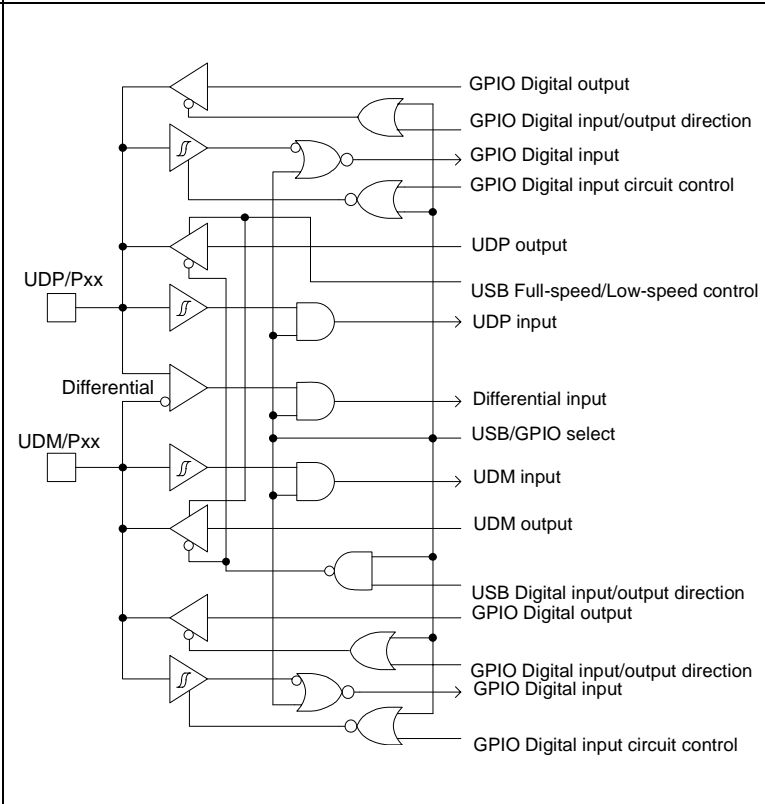
| Type | Circuit | Remarks |
|------|---|---|
| G |  <p>The diagram shows a CMOS output stage. A pull-up resistor R is connected to the output node. The output node is connected to a P-channel MOSFET (P-ch) and an N-channel MOSFET (N-ch). The P-ch MOSFET's gate is connected to a digital input signal. The N-ch MOSFET's gate is connected to a digital input signal through an inverter. The output node is also connected to a digital output signal. A pull-up resistor control signal is connected to the gate of the P-ch MOSFET. A standby mode control signal is connected to the gates of both MOSFETs through an inverter.</p> | <ul style="list-style-type: none"> • CMOS level output • CMOS level hysteresis input • Pull-up resistor control • Standby mode control • Pull-up resistor: approximately 50 kΩ • $I_{OH} = -12 \text{ mA}$, $I_{OL} = 12 \text{ mA}$ • When this pin is used as an I²C pin, the digital output P-ch transistor is always off. |
| H |  <p>The diagram shows a complex digital logic circuit. It includes several inverters, AND gates, OR gates, and multiplexers. The circuit is connected to various pins: UDP/Pxx, Differential, UDM/Pxx, and GPIO Digital output. The outputs of the logic components are labeled: GPIO Digital output, GPIO Digital input/output direction, GPIO Digital input, GPIO Digital input circuit control, UDP output, USB Full-speed/Low-speed control, UDP input, Differential input, USB/GPIO select, UDM input, UDM output, USB Digital input/output direction, GPIO Digital output, GPIO Digital input/output direction, GPIO Digital input, and GPIO Digital input circuit control.</p> | <p>It is possible to select either USB I/O or GPIO function.</p> <p>When the USB I/O is selected:</p> <ul style="list-style-type: none"> • Full-speed, low-speed control <p>When the GPIO is selected:</p> <ul style="list-style-type: none"> • CMOS level output • CMOS level hysteresis input • Standby mode control • $I_{OH} = -20.5 \text{ mA}$, $I_{OL} = 18.5 \text{ mA}$ |

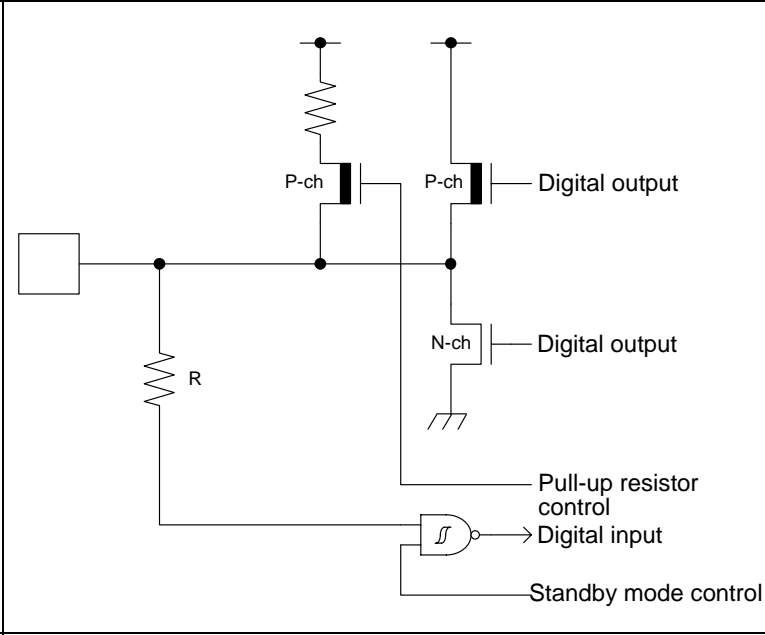
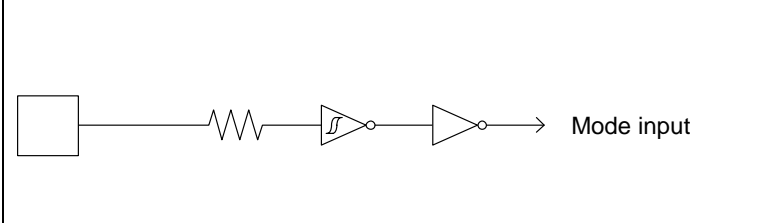
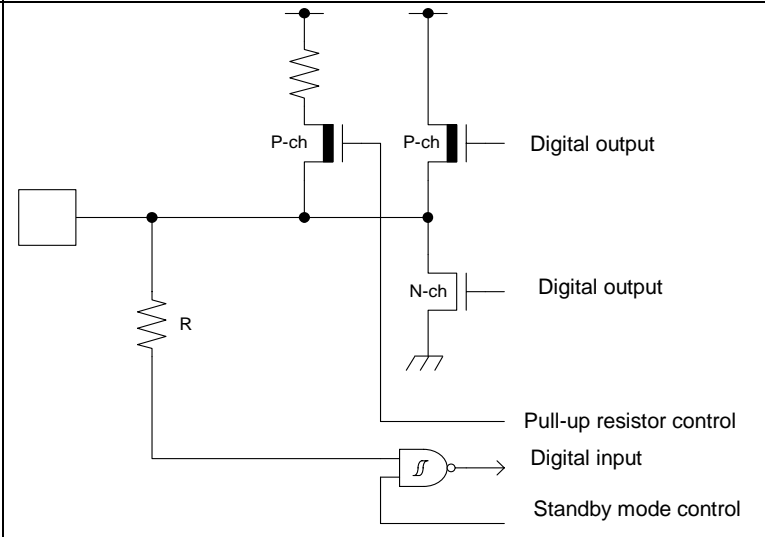
| Type | Circuit | Remarks |
|------|---|--|
| I |  | <ul style="list-style-type: none"> • CMOS level output • CMOS level hysteresis input • 5 V tolerant • Pull-up resistor control • Standby mode control • Pull-up resistor: approximately 50 kΩ • $I_{OH} = -4 \text{ mA}$, $I_{OL} = 4 \text{ mA}$ • Available to control of PZR registers (pseudo-open drain control) • For PZR registers, refer to GPIO in the FM4 Family Peripheral Manual Main Part (MN709-00001). |
| J |  | <p>CMOS level hysteresis input</p> |
| K |  | <ul style="list-style-type: none"> • CMOS level output • TTL level hysteresis input • Pull-up resistor control • Standby mode control • Pull-up resistor: approximately 50 kΩ • $I_{OH} = -4 \text{ mA}$, $I_{OL} = 4 \text{ mA}$ |

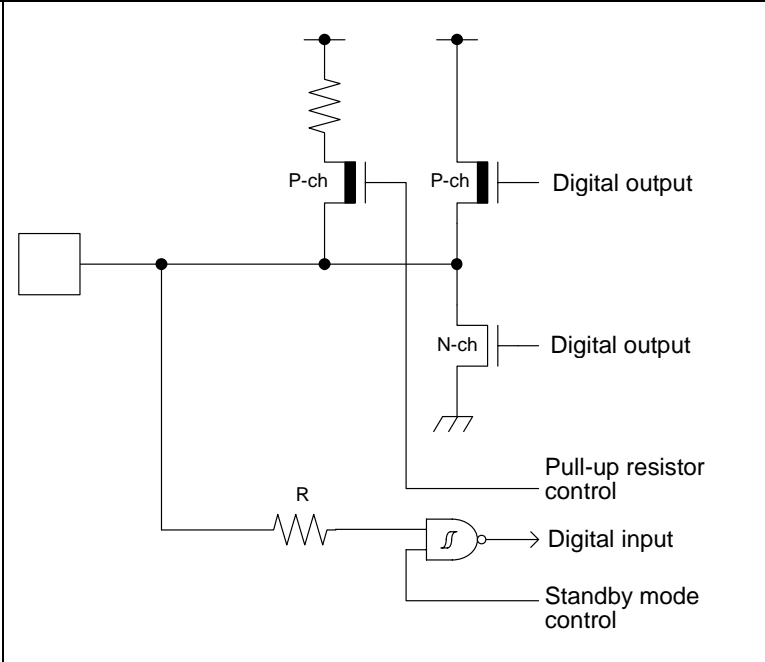
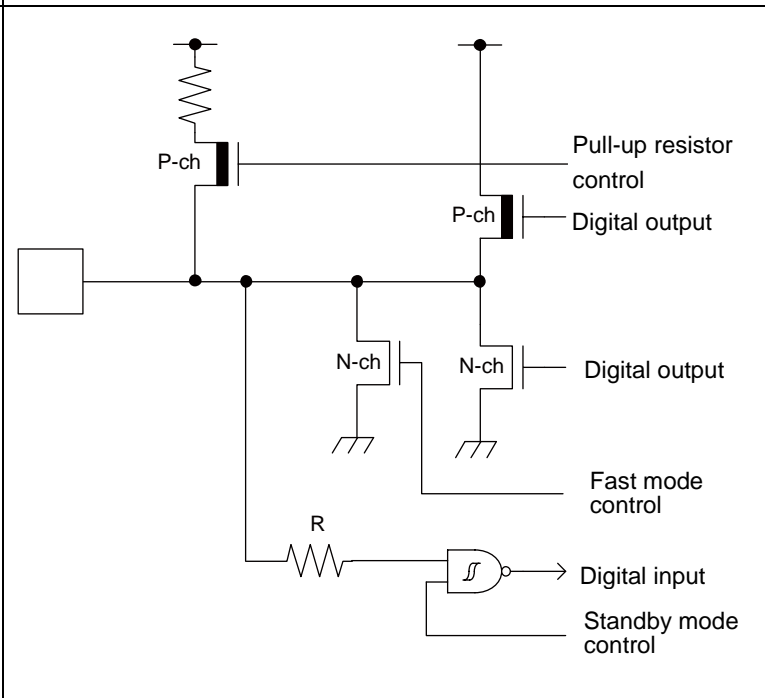
| Type | Circuit | Remarks |
|------|--|--|
| L |  | <ul style="list-style-type: none"> • CMOS level output • CMOS level hysteresis input • Pull-up resistor control • Standby mode control • Pull-up resistor: approximately 50 kΩ • $I_{OH} = -8 \text{ mA}$, $I_{OL} = 8 \text{ mA}$ • When this pin is used as an I²C pin, the digital output P-ch transistor is always off. |
| N |  | <ul style="list-style-type: none"> • CMOS level output • CMOS level hysteresis input • 5V tolerant • Pull-up resistor control • Standby mode control • Pull-up resistor: approximately 50 kΩ • $I_{OH} = -4 \text{ mA}$, $I_{OL} = 4 \text{ mA}$ (GPIO) • $I_{OL} = 20 \text{ mA}$ (Fast mode Plus) • Available to control of PZR register (pseudo-open drain control) • For PZR registers, refer to GPIO in the FM4 Family Peripheral Manual Main Part (MN709-00001). • When this pin is used as an I²C pin, the digital output P-ch transistor is always off. |

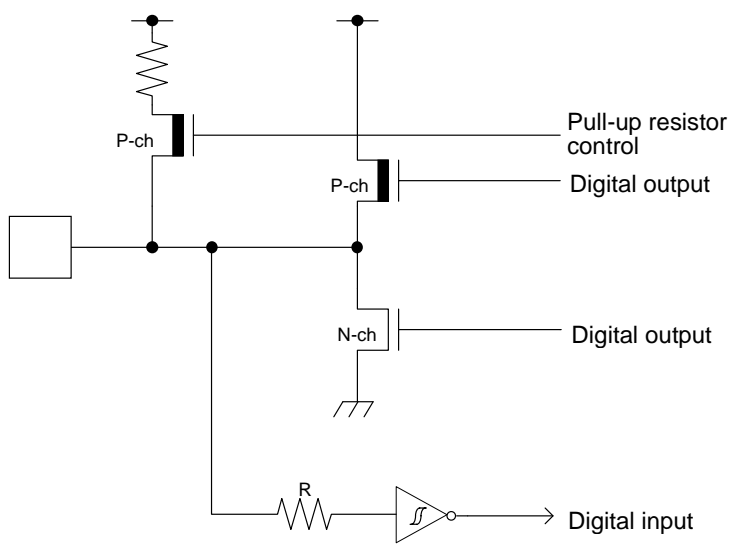
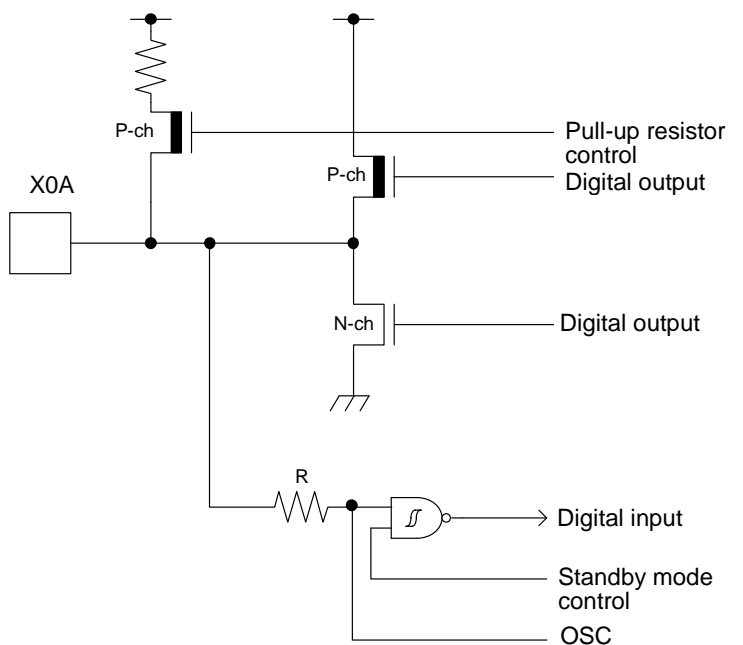
| Type | Circuit | Remarks |
|------|--|---|
| O |  | <ul style="list-style-type: none"> • CMOS level output • CMOS level hysteresis input • 5 V tolerant • Pull-up resistor control • Pull-up resistor: approximately 50 kΩ • $I_{OH} = -4 \text{ mA}$, $I_{OL} = 4 \text{ mA}$ • Available to control of PZR register (pseudo-open drain control) • For PZR registers, refer to GPIO in the “FM4 Family Peripheral Manual Main Part (MN709-00001)”. |
| P |  | <ul style="list-style-type: none"> • CMOS level output • CMOS level hysteresis input • Pull-up resistor control • Pull-up resistor: approximately 50 kΩ • $I_{OH} = -4 \text{ mA}$, $I_{OL} = 4 \text{ mA}$ |

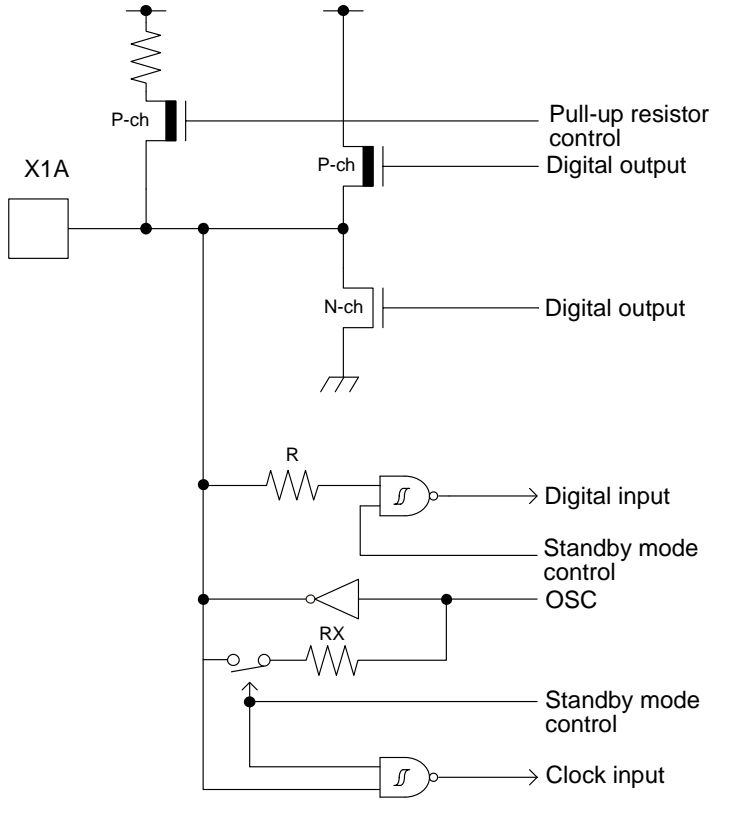
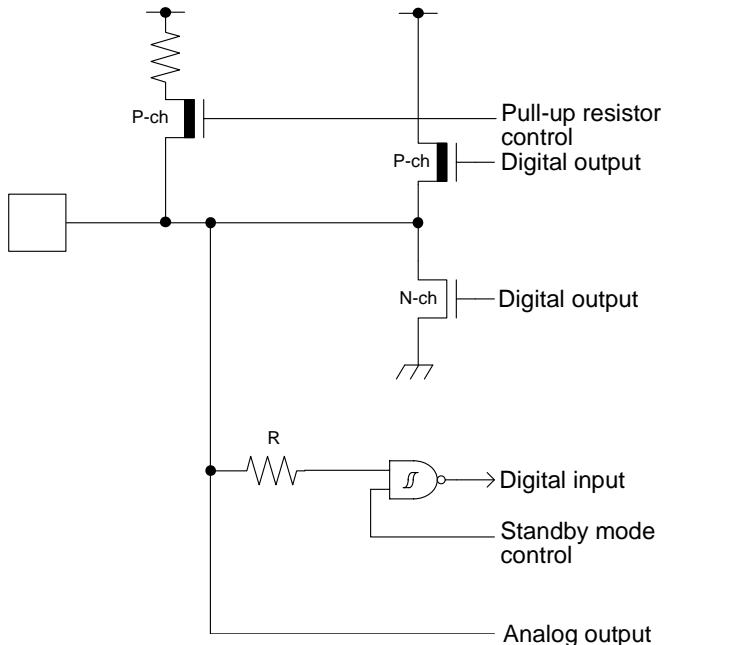
| Type | Circuit | Remarks |
|------|--|--|
| Q |  <p>The circuit diagram for Type Q shows a multiplexer (X1A) with multiple inputs. The outputs are routed to various functions:</p> <ul style="list-style-type: none"> Pull-up resistor control: Connected to a P-channel MOSFET. Digital output: Connected to a P-channel MOSFET. Digital output: Connected to an N-channel MOSFET. Digital input: Connected to an AND gate with a resistor R. Standby mode control: Connected to an AND gate. OSC: Connected to an inverter. Standby mode control: Connected to an AND gate with a resistor RX. Clock input: Connected to an AND gate. | <p>It is possible to select the sub oscillation/GPIO function.</p> <p>When the sub oscillation is selected:</p> <ul style="list-style-type: none"> Oscillation feedback resistor: approximately 10 MΩ <p>When the GPIO is selected:</p> <ul style="list-style-type: none"> CMOS level output. CMOS level hysteresis input Pull-up resistor control Pull-up resistor: approximately 50 kΩ $I_{OH} = -4 \text{ mA}$, $I_{OL} = 4 \text{ mA}$ |
| R |  <p>The circuit diagram for Type R shows a multiplexer (X1A) with multiple inputs. The outputs are routed to various functions:</p> <ul style="list-style-type: none"> Pull-up resistor control: Connected to a P-channel MOSFET. Digital output: Connected to a P-channel MOSFET. Digital output: Connected to an N-channel MOSFET. Digital input: Connected to an AND gate with a resistor R. Standby mode control: Connected to an AND gate. Analog output: Connected to the multiplexer output. | <ul style="list-style-type: none"> CMOS level output CMOS level hysteresis input Analog output Pull-up resistor control Standby mode control Pull-up resistor: approximately 50 kΩ $I_{OH} = -4 \text{ mA}$, $I_{OL} = 4 \text{ mA}$ (4.5V to 5.5V) $I_{OH} = -2 \text{ mA}$, $I_{OL} = 2 \text{ mA}$ (2.7V to 4.5V) |

6. Handling Precautions

Every semiconductor device has a characteristic, inherent rate of failure. The possibility of failure is greatly affected by the conditions in which they are used (circuit conditions, environmental conditions, etc.). This page describes precautions that must be observed to minimize the chance of failure and to obtain higher reliability from your Cypress semiconductor devices.

6.1 Precautions for Product Design

This section describes precautions when designing electronic equipment using semiconductor devices.

Absolute Maximum Ratings

Semiconductor devices can be permanently damaged by application of stress (voltage, current, temperature, etc.) in excess of certain established limits, called absolute maximum ratings. Do not exceed these ratings.

Recommended Operating Conditions

Recommended operating conditions are normal operating ranges for the semiconductor device. All the device's electrical characteristics are warranted when operated within these ranges.

Always use semiconductor devices within the recommended operating conditions. Operation outside these ranges may adversely affect reliability and could result in device failure.

No warranty is made with respect to uses, operating conditions, or combinations not represented on the data sheet. Users considering application outside the listed conditions are advised to contact their sales representative beforehand.

Processing and Protection of Pins

These precautions must be followed when handling the pins that connect semiconductor devices to power supply and I/O functions.

1. Preventing Over-Voltage and Over-Current Conditions

Exposure to voltage or current levels in excess of maximum ratings at any pin is likely to cause deterioration within the device, and in extreme cases leads to permanent damage of the device. Try to prevent such overvoltage or over-current conditions at the design stage.

2. Protection of Output Pins

Shorting of output pins to supply pins or other output pins, or connection to large capacitance can cause large current flows. Such conditions, if present for extended periods of time, can damage the device; therefore, avoid this type of connection.

3. Handling of Unused Input Pins

Unconnected input pins with very high impedance levels can adversely affect stability of operation. Such pins should be connected through an appropriate resistance to a power-supply pin or ground pin.

Code: DS00-00004-3E

Latch-Up

Semiconductor devices are constructed by the formation of p-type and n-type areas on a substrate. When subjected to abnormally high voltages, internal parasitic pnpn junctions (called thyristor structures) may be formed, causing large current levels in excess of several hundred milliamps to flow continuously at the power supply pin. This condition is called latch-up.

CAUTION: The occurrence of latch-up not only causes loss of reliability in the semiconductor device, but can cause injury or damage from high heat, smoke or flame. To prevent this from happening, do the following:

1. Be sure that voltages applied to pins do not exceed the absolute maximum ratings. This should include attention to abnormal noise, surge levels, etc.
2. Be sure that abnormal current flows do not occur during the power-on sequence.

Observance of Safety Regulations and Standards

Most countries in the world have established standards and regulations regarding safety, protection from electromagnetic interference, etc. Customers are requested to observe applicable regulations and standards in the design of products.

Fail-Safe Design

As previously mentioned, all semiconductor devices have inherent rates of failure. You must protect against injury, damage or loss from such failures by incorporating safety design measures into your facility and equipment such as redundancy, fire protection, and prevention of over-current levels and other abnormal operating conditions.

Precautions Related to Usage of Devices

Cypress semiconductor devices are intended for use in standard applications (computers, office automation and other office equipment, industrial, communications, and measurement equipment, personal or household devices, etc.).

CAUTION: Customers considering the use of our products in special applications where failure or abnormal operation may directly affect human lives or cause physical injury or property damage, or where extremely high levels of reliability are demanded (such as aerospace systems, atomic energy controls, sea floor repeaters, vehicle operating controls, medical devices for life support, etc.) are requested to consult with sales representatives before such use. The company will not be responsible for damages arising from such use without prior approval.

6.2 Precautions for Package Mounting

Package mounting may be either lead insertion type or surface mount type. In either case, for heat resistance during soldering, you should only mount under Cypress's recommended conditions. For detailed information about mount conditions, contact your sales representative.

Lead Insertion Type

Mounting of lead insertion type packages onto printed circuit boards may be done by two methods: direct soldering on the board, or mounting by using a socket.

Direct mounting onto boards normally involves processes for inserting leads into through-holes on the board and using the flow soldering (wave soldering) method of applying liquid solder. In this case, the soldering process usually causes leads to be subjected to thermal stress in excess of the absolute ratings for storage temperature. Mounting processes should conform to Cypress recommended mounting conditions.

If socket mounting is used, differences in surface treatment of the socket contacts and IC lead surfaces can lead to contact deterioration after long periods. For this reason it is recommended that the surface treatment of socket contacts and IC leads be verified before mounting.

Surface Mount Type

Surface mount packaging has longer and thinner leads than lead-insertion packaging, and therefore leads are more easily deformed or bent. The use of packages with higher pin counts and narrower pin pitch results in increased susceptibility to open connections caused by deformed pins, or shorting due to solder bridges.

You must use appropriate mounting techniques. Cypress recommends the solder reflow method, and has established a ranking of mounting conditions for each product. Users are advised to mount packages in accordance with Cypress ranking of recommended conditions.

Lead-Free Packaging

CAUTION: When ball grid array (BGA) packages with Sn-Ag-Cu balls are mounted using Sn-Pb eutectic soldering, junction strength may be reduced under some conditions of use.

Storage of Semiconductor Devices

Because plastic chip packages are formed from plastic resins, exposure to natural environmental conditions will cause absorption of moisture. During mounting, the application of heat to a package that has absorbed moisture can cause surfaces to peel, reducing moisture resistance and causing packages to crack. To prevent this, do the following:

1. Avoid exposure to rapid temperature changes, which can cause moisture to condense inside the product. Store products in locations where temperature changes are slight.
2. Use dry boxes for product storage. Products should be stored below 70% relative humidity, and at temperatures between 5°C and 30°C.
3. When Dry Packages are opened, it is recommended to have humidity between 40% and 70%.
4. When necessary, Cypress packages semiconductor devices in highly moisture-resistant aluminum laminate bags, with a silica gel desiccant. Devices should be sealed in these aluminum laminate bags for storage.
5. Avoid storing packages where they are exposed to corrosive gases or high levels of dust.

Baking

Packages that have absorbed moisture may be de-moisturized by baking (heat drying). Follow the Cypress recommended conditions for baking.

Condition: 125°C/24 h

Static Electricity

Because semiconductor devices are particularly susceptible to damage by static electricity, you must take the following precautions:

1. Maintain relative humidity in the working environment between 40% and 70%. Use of an apparatus for ion generation may be needed to remove electricity.
2. Electrically ground all conveyors, solder vessels, soldering irons, and peripheral equipment.
3. Eliminate static body electricity by the use of rings or bracelets connected to ground through high resistance (on the level of 1 MΩ). Wearing of conductive clothing and shoes, and the use of conductive floor mats and other measures to minimize shock loads is recommended.
4. Ground all fixtures and instruments, or protect with anti-static measures.
5. Avoid the use of Styrofoam or other highly static-prone materials for storage of completed board assemblies.

6.3 Precautions for Use Environment

Reliability of semiconductor devices depends on ambient temperature and other conditions as described above.

For reliable performance, do the following:

1. Humidity

Prolonged use in high humidity can lead to leakage in devices as well as printed circuit boards. If high humidity levels are anticipated, consider anti-humidity processing.

2. Discharge of static electricity

When high-voltage charges exist close to semiconductor devices, discharges can cause abnormal operation. In such cases, use anti-static measures or processing to prevent discharges.

3. Corrosive gases, dust, or oil

Exposure to corrosive gases or contact with dust or oil may lead to chemical reactions that will adversely affect the device. If you use devices in such conditions, consider ways to prevent such exposure or to protect the devices.

4. Radiation, including cosmic radiation

Most devices are not designed for environments involving exposure to radiation or cosmic radiation. Users should provide shielding as appropriate.

5. Smoke, flame

CAUTION: Plastic molded devices are flammable and therefore should not be used near combustible substances. If devices begin to smoke or burn, there is danger of the release of toxic gases.

Customers considering the use of Cypress products in other special environmental conditions should consult with sales representatives.

Please check the latest handling precautions at the following URL.

<http://www.spansion.com/fjdocuments/fj/datasheet/e-ds/DS00-00004.pdf>

7. Handling Devices

Power-Supply Pins

In products with multiple VCC and VSS pins, respective pins at the same potential are interconnected within the device in order to prevent malfunctions such as latch-up. All of these pins should be connected externally to the power supply or ground lines, however, in order to reduce electromagnetic emission levels, to prevent abnormal operation of strobe signals caused by the rise in the ground level, and to conform to the total output current rating.

Be sure to connect the current-supply source with the power pins and GND pins of this device at low impedance. It is also advisable that a ceramic capacitor of approximately 0.1 μF be connected as a bypass capacitor between VCC and VSS near this device.

A malfunction may occur when the power-supply voltage fluctuates rapidly even though the fluctuation is within the guaranteed operating range of the VCC power supply voltage. As a rule of voltage stabilization, suppress voltage fluctuation so that the fluctuation in VCC ripple (peak-to-peak value) at the commercial frequency (50 Hz/60 Hz) does not exceed 10% of the standard VCC value, and the transient fluctuation rate does not exceed 0.1V/ μs at a momentary fluctuation such as switching the power supply.

Crystal Oscillator Circuit

Noise near the X0/X1 and X0A/X1A pins may cause the device to malfunction. Design the printed circuit board so that X0/X1, X0A/X1A pins, the crystal oscillator (or ceramic oscillator), and the bypass capacitor to ground are located as close to the device as possible.

It is strongly recommended that the PC board artwork be designed such that the X0/X1 and X0A/X1A pins are surrounded by ground plane, as this is expected to produce stable operation.

Evaluate the oscillation introduced by the use of the crystal oscillator by your mount board.

Sub Crystal Oscillator

The sub-oscillator circuit for devices in this family is low gain to keep current consumption low. To stabilize the oscillation, Cypress recommends a crystal oscillator that meets the following conditions:

- Surface mount type
 - Size: More than 3.2 mm \times 1.5 mm
 - Load capacitance: approximately 6 pF to 7 pF
- Lead type
 - Load capacitance: approximately 6 pF to 7 pF

Using an External Clock

When using an external clock as an input of the main clock, set X0/X1 to the external clock input, and input the clock to X0. X1(PE3) can be used as a general-purpose I/O port. Similarly, when using an external clock as an input of the sub clock, set X0A/X1A to the external clock input and input the clock to X0A. X1A (P47) can be used as a general-purpose I/O port.

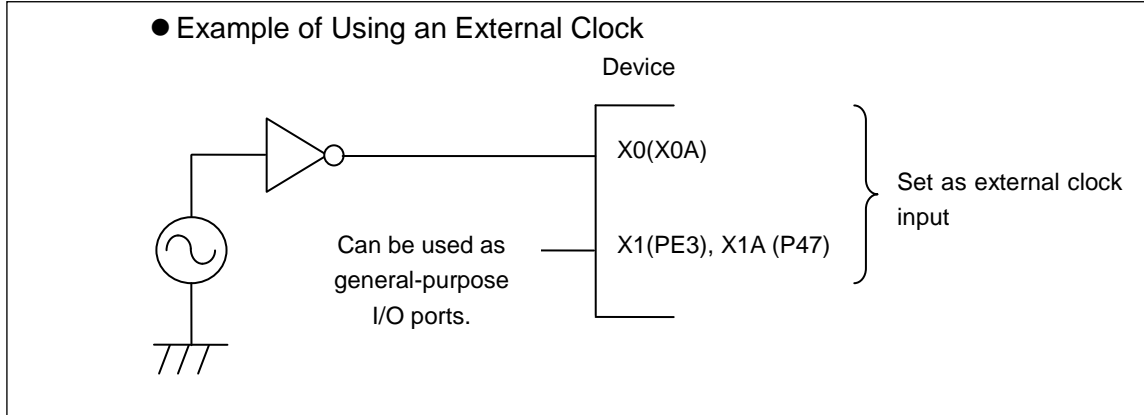

Handling When Using Multi-Function Serial Pin as I²C Pin

If the application uses the multi-function serial pin as an I²C pin, the P-channel transistor of the digital output must be disabled. I²C pins need to conform to electrical limitations like other pins, however, and avoid connecting to live external systems with the MCU power off.

C Pin

Devices in this series contain a regulator. Be sure to connect a smoothing capacitor (C_S) for the regulator between the C pin and the GND pin. Please use a ceramic capacitor or a capacitor of equivalent frequency characteristics as a smoothing capacitor. Some laminated ceramic capacitors have a large capacitance variation due to thermal fluctuation. Please select a capacitor that meets the specifications in the operating conditions to use by evaluating the temperature characteristics of the device. A smoothing capacitor of about 4.7 μF would be recommended for this series.

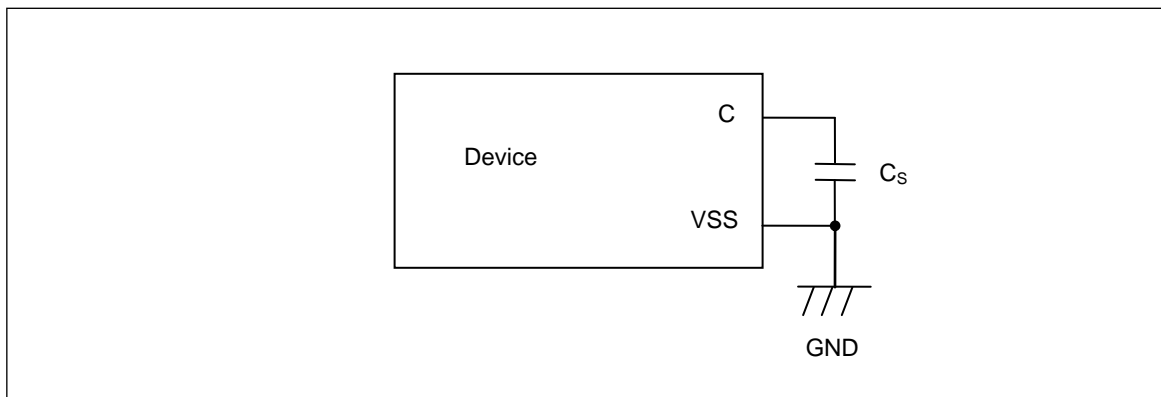

Mode Pins (MD0)

Connect the MD pin (MD0) directly to VCC or VSS pins. Design the printed circuit board such that the pull-up/down resistance stays low, the distance between the mode pins and VCC pins or VSS pins is as short as possible, and the connection impedance is low when the pins are pulled up/down such as for switching the pin level and rewriting the flash memory data. This is important to prevent the device from erroneously switching to test mode as a result of noise.

Notes on Power-On

Turn power on/off in the sequence shown below or at the same time. If not using the A/D converter and D/A converter, connect AVCC = VCC and AVSS = VSS.

Turning on: VCC → USBVCC0
VCC → USBVCC1
VCC → ETHVCC
VCC → AVCC → AVRH
Turning off: USBVCC0 → VCC
USBVCC1 → VCC
ETHVCC → VCC
AVRH → AVCC → VCC

Serial Communication

There is a possibility of receiving incorrect data as a result of noise or other issues introduced by the serial communication. Take care to design the printed circuit board to minimize noise.

Consider the case of introducing error as a result of noise, perform error detection such as by applying a checksum of data at the end. If an error is detected, retransmit the data.

Differences in Characteristics within the Product Line

The electric characteristics including power consumption, ESD, latch-up, noise, and oscillation differ among members of the product line because chip layout and memory structures are not the same; for example, different sizes, flash versus ROM, etc. If you are switching to a different product of the same series, please make sure to evaluate the electric characteristics.

Pull-Up Function of 5 V Tolerant I/O

Please do not input the signal more than VCC voltage at the time of Pull-Up function use of 5 V tolerant I/O.

Pin Doubled as Debug Function

The pin doubled as TDO/TMS/TDI/TCK/TRSTX, SWO/SWDIO/SWCLK should be used as output only. Do not use as input.

8. Block Diagram

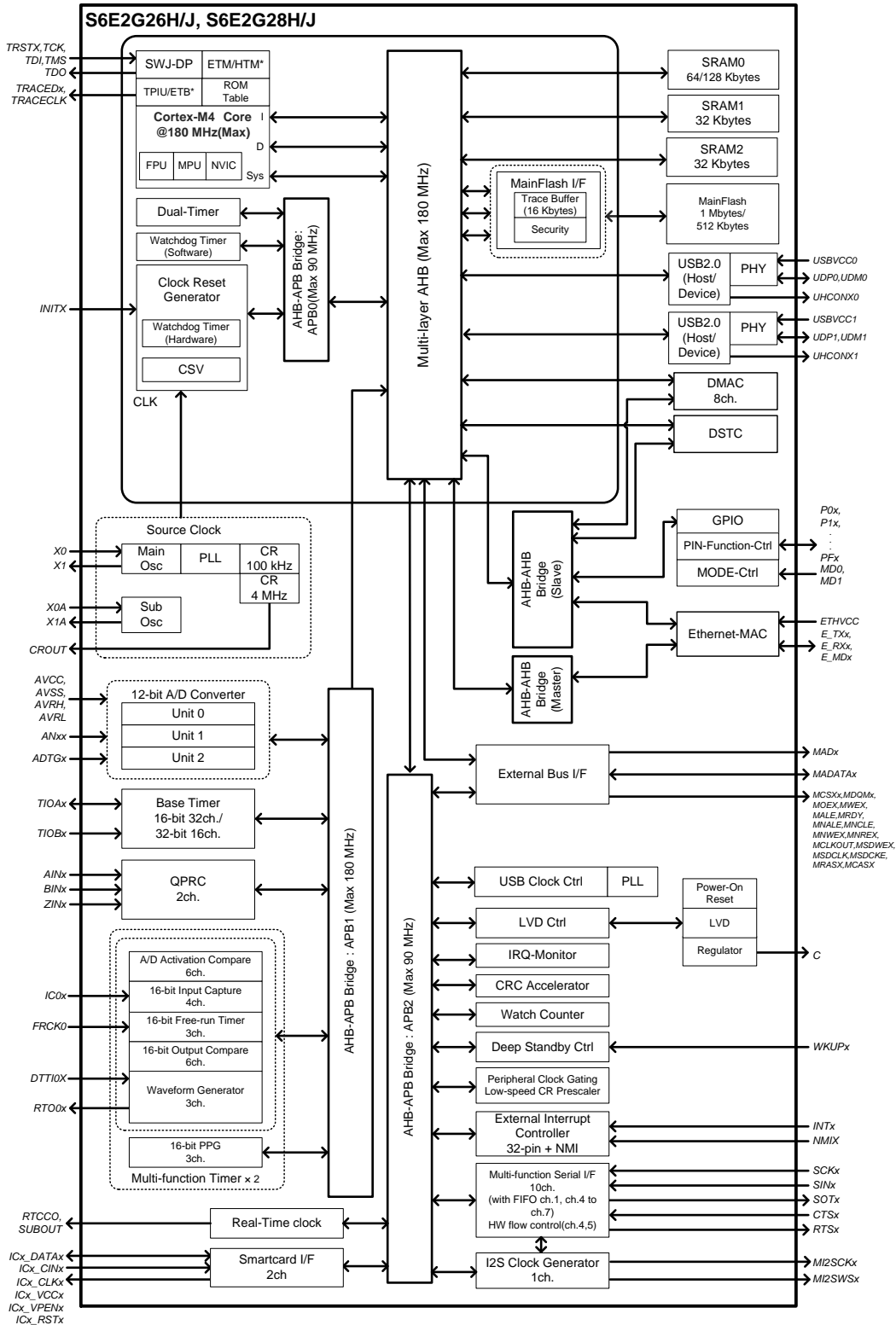

9. Memory Size

See Memory size in 1. Product Lineup to confirm the memory size.

10. Memory Map

Memory Map (1)

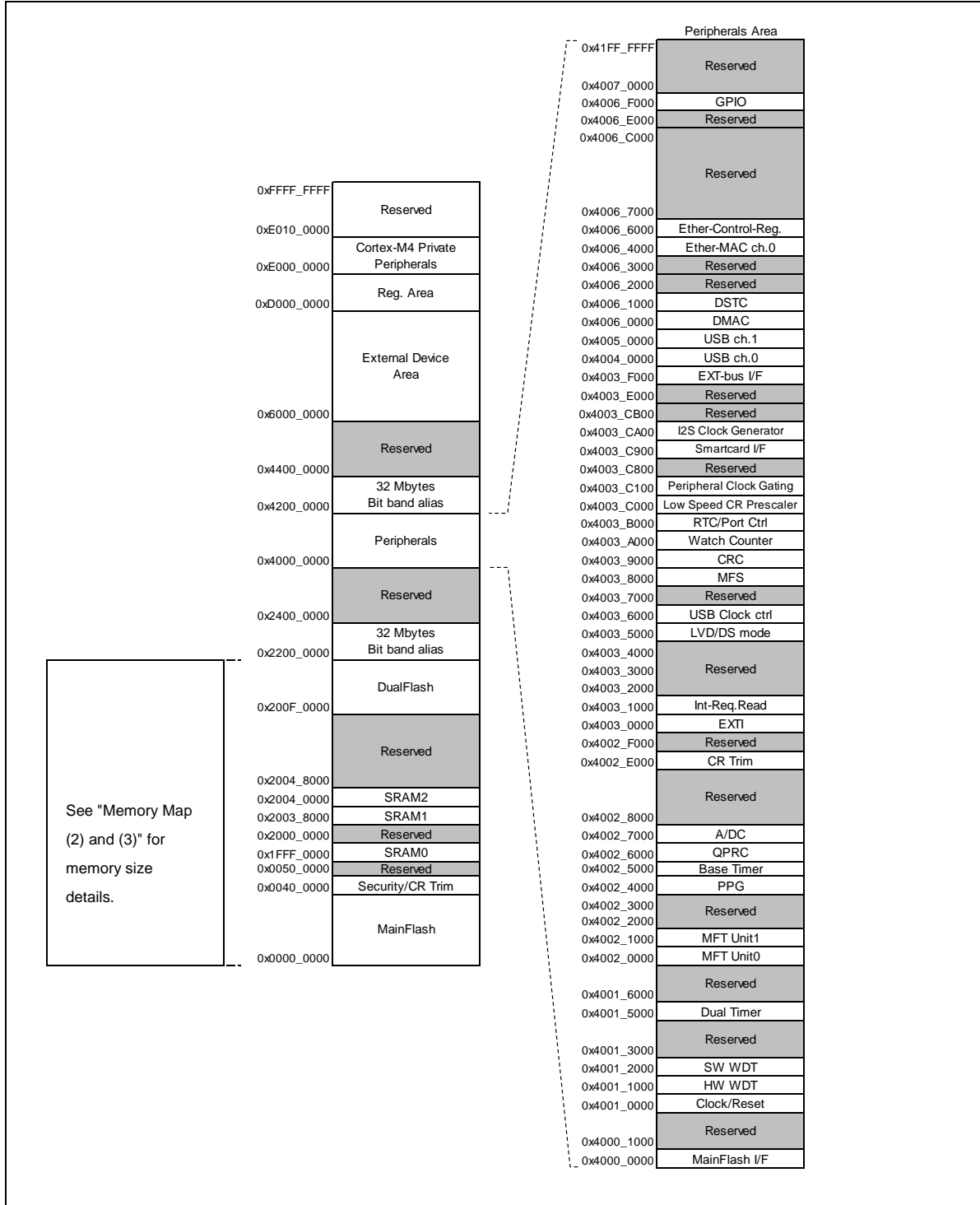

See "Memory Map (2) and (3)" for memory size details.

Memory Map (2)

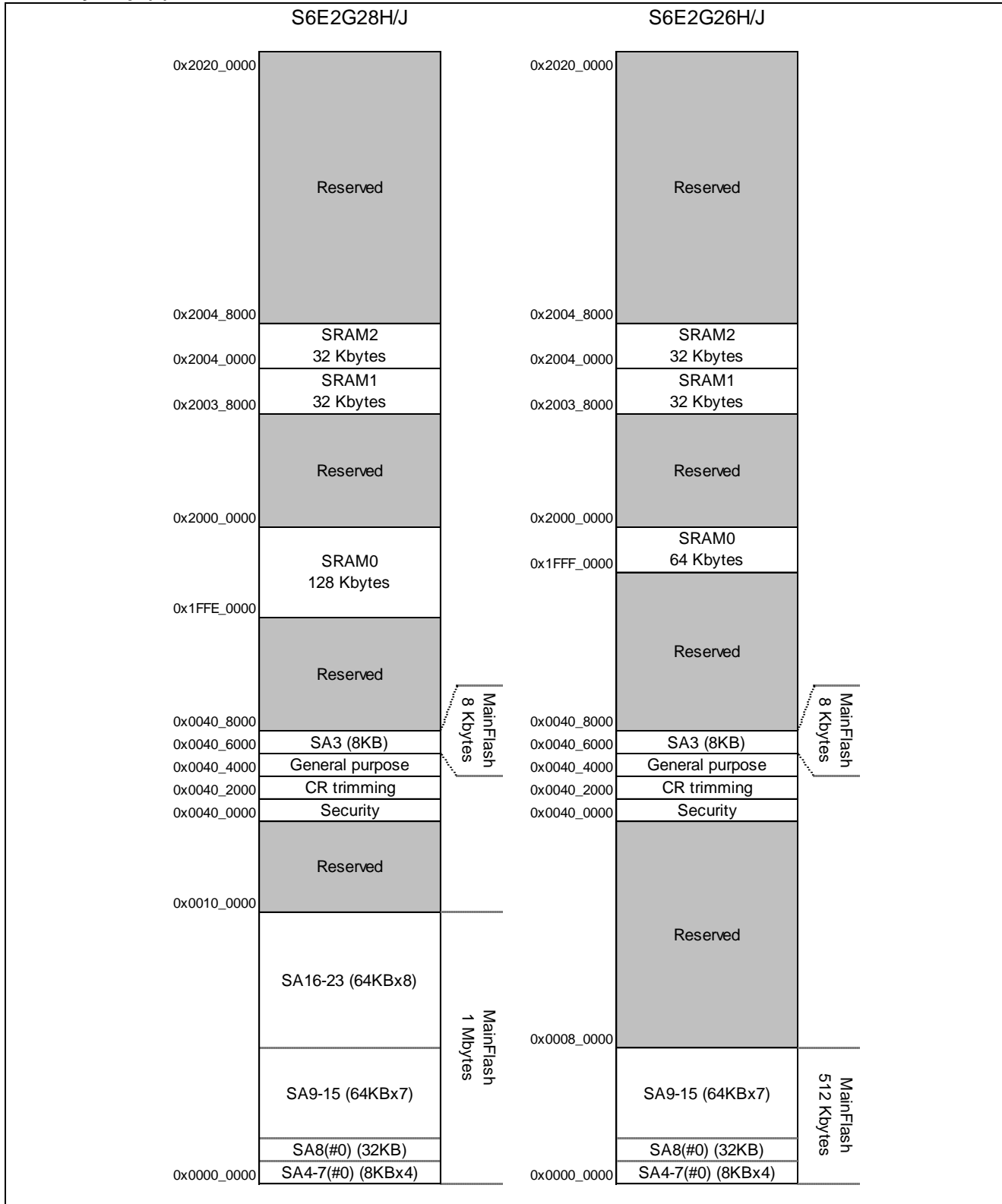

*: See S6E2GM/GK/GH/G3/G2 Series Flash Programming Manual to confirm the detail of flash Memory.

Memory Map (3)

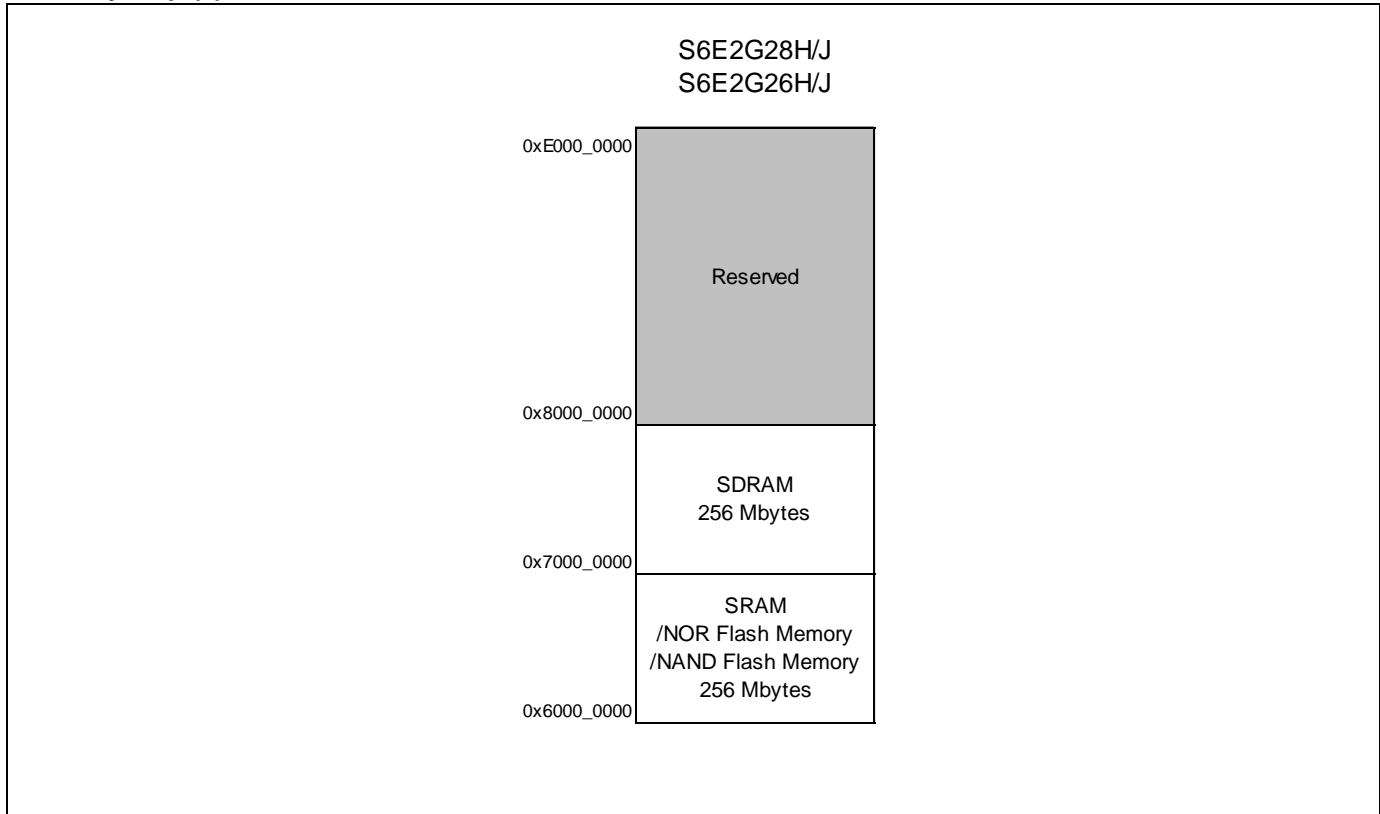

Peripheral Address Map

| Start Address | End Address | Bus | Peripherals | |
|---------------|-------------|--|---------------------------------------|-------------------------------|
| 0x4000_0000 | 0x4000_0FFF | AHB | MainFlash I/F register | |
| 0x4000_1000 | 0x4000_FFFF | | Reserved | |
| 0x4001_0000 | 0x4001_0FFF | APB0 | Clock/reset control | |
| 0x4001_1000 | 0x4001_1FFF | | Hardware watchdog timer | |
| 0x4001_2000 | 0x4001_2FFF | | Software watchdog timer | |
| 0x4001_3000 | 0x4001_4FFF | | Reserved | |
| 0x4001_5000 | 0x4001_5FFF | | Dual-timer | |
| 0x4001_6000 | 0x4001_FFFF | | Reserved | |
| 0x4002_0000 | 0x4002_0FFF | | APB1 | Multi-Function Timer unit 0 |
| 0x4002_1000 | 0x4002_1FFF | Multi-Function Timer unit 1 | | |
| 0x4002_2000 | 0x4002_3FFF | Reserved | | |
| 0x4002_4000 | 0x4002_4FFF | PPG | | |
| 0x4002_5000 | 0x4002_5FFF | Base timer | | |
| 0x4002_6000 | 0x4002_6FFF | Quadrature position/revolution counter | | |
| 0x4002_7000 | 0x4002_7FFF | A/D converter | | |
| 0x4002_8000 | 0x4002_DFFF | Reserved | | |
| 0x4002_E000 | 0x4002_EFFF | Internal CR trimming | | |
| 0x4002_F000 | 0x4002_FFFF | Reserved | | |
| 0x4003_0000 | 0x4003_0FFF | APB2 | | External interrupt controller |
| 0x4003_1000 | 0x4003_1FFF | | Interrupt request batch-read function | |
| 0x4003_2000 | 0x4003_4FFF | | Reserved | |
| 0x4003_5000 | 0x4003_57FF | | Low voltage detector | |
| 0x4003_5800 | 0x4003_5FFF | | Deep standby mode Controller | |
| 0x4003_6000 | 0x4003_6FFF | | USB clock generator | |
| 0x4003_7000 | 0x4003_7FFF | | Reserved | |
| 0x4003_8000 | 0x4003_8FFF | | Multi-function serial interface | |
| 0x4003_9000 | 0x4003_9FFF | | CRC | |
| 0x4003_A000 | 0x4003_AFFF | | Watch counter | |
| 0x4003_B000 | 0x4003_BFFF | | RTC/port control | |
| 0x4003_C000 | 0x4003_C0FF | | Low-speed CR prescaler | |
| 0x4003_C100 | 0x4003_C7FF | | Peripheral clock gating | |
| 0x4003_C800 | 0x4003_C8FF | | Reserved | |
| 0x4003_C900 | 0x4003_C9FF | | I2S clock generator | |
| 0x4003_CA00 | 0x4003_CAFF | | Smartcard Interface | |
| 0x4003_CB00 | 0x4003_EFFF | | Reserved | |
| 0x4003_F000 | 0x4003_FFFF | | External memory interface | |
| 0x4004_0000 | 0x4004_FFFF | | AHB | USB ch 0 |
| 0x4005_0000 | 0x4005_FFFF | | | USB ch 1 |
| 0x4006_0000 | 0x4006_0FFF | | | DMAC register |
| 0x4006_1000 | 0x4006_1FFF | DSTC register | | |
| 0x4006_2000 | 0x4006_2FFF | Reserved | | |
| 0x4006_3000 | 0x4006_3FFF | Reserved | | |
| 0x4006_4000 | 0x4006_5FFF | Ethernet-MAC ch 0 | | |
| 0x4006_6000 | 0x4006_6FFF | Ethernet-MAC setting register | | |
| 0x4006_7000 | 0x4006_DFFF | Reserved | | |
| 0x4006_E000 | 0x4006_EFFF | Reserved | | |
| 0x4006_F000 | 0x4006_FFFF | GPIO | | |
| 0x4007_0000 | 0x41FF_FFFF | Reserved | | |

11. Pin Status in Each CPU State

The terms used for pin status have the following meanings:

■ INITX = 0

This is the period when the INITX pin is at the L level.

■ INITX = 1

This is the period when the INITX pin is at the H level.

■ SPL = 0

This is the status that the standby pin level setting bit (SPL) in the standby mode control register (STB_CTL) is set to 0.

■ SPL = 1

This is the status that the standby pin level setting bit (SPL) in the standby mode control register (STB_CTL) is set to 1.

■ Input enabled

Indicates that the input function can be used.

■ Internal input fixed at 0

This is the status that the input function cannot be used. Internal input is fixed at L.

■ Hi-Z

Indicates that the pin drive transistor is disabled and the pin is put in the Hi-Z state.

■ Setting disabled

Indicates that the setting is disabled.

■ Maintain previous state

Maintains the state that was immediately prior to entering the current mode.
If a built-in peripheral function is operating, the output follows the peripheral function.
If the pin is being used as a port, that output is maintained.

■ Analog input is enabled

Indicates that the analog input is enabled.

■ Trace output

Indicates that the trace function can be used.

■ GPIO selected

In Deep standby mode, pins switch to the general-purpose I/O port.

■ Setting prohibition

Prohibition of a setting by specification limitation

List of Pin Behavior by Mode State

| Pin Status Type | Function Group | Power-On Reset or Low-Voltage Detection State | INITX Input State | Device Internal Reset State | Run mode or Sleep mode State | Timer mode, RTC mode, or Stop mode State | | Deep Standby RTC mode or Deep Standby Stop mode State | | Return from Deep Standby mode State |
|-----------------|---|---|---------------------------------|---------------------------------|---|--|---------------------------------|---|--------------------------------|-------------------------------------|
| | | Power Supply Unstable | Power Supply Stable | | Power Supply Stable | Power Supply Stable | | Power Supply Stable | | Power Supply Stable |
| | | - | INITX=0 | INITX=1 | INITX=1 | INITX=1 | | INITX=1 | | INITX=1 |
| | | - | - | - | - | SPL=0 | SPL=1 | SPL=0 | SPL=1 | - |
| A | GPIO selected | Setting disabled | Setting disabled | Setting disabled | Maintain previous state | Maintain previous state | Hi-Z/internal input fixed at 0 | GPIO selected, internal input fixed at 0 | Hi-Z/internal input fixed at 0 | GPIO selected |
| | Main crystal oscillator input pin/ external main clock input selected | Input enabled | Input enabled | Input enabled | Input enabled | Input enabled | Input enabled | Input enabled | Input enabled | Input Enabled |
| B | GPIO selected | Setting disabled | Setting disabled | Setting disabled | Maintain previous state | Maintain previous state | Hi-Z/internal input fixed at 0 | GPIO selected, internal input fixed at 0 | Hi-Z/internal input fixed at 0 | GPIO selected |
| | External main clock input selected | Setting disabled | Setting disabled | Setting disabled | Maintain previous state | Maintain previous state | Hi-Z/internal input fixed at 0 | Maintain previous state | Hi-Z/internal input fixed at 0 | Maintain previous State |
| | Main crystal oscillator output pin | Hi-Z/ internal input fixed at 0/ or input enabled | Hi-Z/ internal input fixed at 0 | Hi-Z/ internal input fixed at 0 | Maintain previous state while oscillator active/ When oscillation stops*1, it will be Hi-Z/ Internal input fixed at 0 | | | | | |
| C | INITX input pin | Pull-up/ input enabled | Pull-up/ Input enabled | Pull-up/ Input enabled | Pull-up/ Input enabled | Pull-up/ Input enabled | Pull-up/ Input enabled | Pull-up/ Input enabled | Pull-up/ Input enabled | Pull-up/ Input enabled |
| D | Mode input pin | Input enabled | Input enabled | Input enabled | Input enabled | Input enabled | Input enabled | Input enabled | Input enabled | Input enabled |
| E | Mode input pin | Input enabled | Input enabled | Input enabled | Input enabled | Input enabled | Input enabled | Input enabled | Input enabled | Input enabled |
| | GPIO selected | Setting disabled | Setting disabled | Setting disabled | Maintain previous state | Maintain previous state | Hi-Z/ input enabled | GPIO selected | Hi-Z/ input enabled | GPIO selected |
| F | NMIX selected | Setting disabled | Setting disabled | Setting disabled | Maintain previous state | Maintain previous state | Maintain previous state | WKUP input enabled | Hi-Z/ WKUP input enabled | Maintain previous state |
| | Resource other than above selected | Hi-Z | Hi-Z/ input enabled | Hi-Z/ input enabled | | | Hi-Z/ internal input fixed at 0 | | | GPIO selected |
| | GPIO selected | | | | | | | | | |

| Pin Status Type | Function Group | Power-On Reset or Low-Voltage Detection State | INITX Input State | Device Internal Reset State | Run mode or Sleep mode State | Timer mode, RTC mode, or Stop mode State | | Deep Standby RTC mode or Deep Standby Stop mode State | | Return from Deep Standby mode State |
|-----------------|------------------------------------|---|------------------------|-----------------------------|------------------------------|--|---------------------------------|---|---------------------------------|-------------------------------------|
| | | Power Supply Unstable | Power Supply Stable | | Power Supply Stable | Power Supply Stable | | Power Supply Stable | | Power Supply Stable |
| | | - | INITX=0 | INITX=1 | INITX=1 | INITX=1 | | INITX=1 | | INITX=1 |
| | | - | - | - | - | SPL=0 | SPL=1 | SPL=0 | SPL=1 | - |
| G | JTAG selected | Hi-Z | Pull-up/ input enabled | Pull-up/ input enabled | Maintain previous state | Maintain previous state | Maintain previous state | Maintain previous state | Maintain previous state | Maintain previous state |
| | GPIO selected | Setting disabled | Setting disabled | Setting disabled | | | Hi-Z/ internal input fixed at 0 | GPIO selected, internal input fixed at 0 | Hi-Z/ internal input fixed at 0 | GPIO selected |
| H | JTAG selected | Hi-Z | Pull-up/ input enabled | Pull-up/ input enabled | Maintain previous state | Maintain previous state | Maintain previous state | Maintain previous state | Maintain previous state | Maintain previous state |
| | Resource other than above selected | Setting disabled | Setting disabled | Setting disabled | | | Hi-Z/Internall input fixed at 0 | GPIO selected, internal input fixed at 0 | Hi-Z/Internall input fixed at 0 | GPIO selected |
| | GPIO selected | | | | | | | | | |
| I | Resource selected | Hi-Z | Hi-Z/ input enabled | Hi-Z/ input enabled | Maintain previous state | Maintain previous state | Hi-Z/Internall input fixed at 0 | GPIO selected, internal input fixed at 0 | Hi-Z/internall input fixed at 0 | GPIO selected |
| | GPIO selected | | | | | | | | | |
| J | Analog output selected | Hi-Z | Hi-Z/ input enabled | Hi-Z/ input enabled | Maintain previous state | *2 | *3 | GPIO selected, internal input fixed at 0 | Hi-Z/internall input fixed at 0 | GPIO selected |
| | External interrupt enable selected | | | | | Maintain previous state | | | | |
| | Resource other than above selected | | | | | Hi-Z/internall input fixed at 0 | | | | |
| | GPIO selected | | | | | | | | | |
| K | External interrupt enable selected | Setting disabled | Setting disabled | Setting disabled | Maintain previous state | Maintain previous state | Maintain previous state | GPIO selected, internal input fixed at 0 | Hi-Z/internall input fixed at 0 | GPIO selected |
| | Resource other than above selected | Hi-Z | Hi-Z/ input enabled | Hi-Z/ input enabled | | | Hi-Z/internall input fixed at 0 | | | |
| | GPIO selected | | | | | | | | | |

| Pin Status Type | Function Group | Power-On Reset or Low-Voltage Detection State | INITX Input State | Device Internal Reset State | Run mode or Sleep mode State | Timer mode, RTC mode, or Stop mode State | | Deep Standby RTC mode or Deep Standby Stop mode State | | Return from Deep Standby mode State |
|-----------------|---|---|---|---|---|---|---|---|---|---|
| | | Power Supply Unstable | Power Supply Stable | | Power Supply Stable | Power Supply Stable | | Power Supply Stable | | Power Supply Stable |
| | | - | INITX=0 | INITX=1 | INITX=1 | INITX=1 | | INITX=1 | | INITX=1 |
| | | - | - | - | - | SPL=0 | SPL=1 | SPL=0 | SPL=1 | - |
| L | Analog input selected | Hi-Z | Hi-Z/ internal input fixed at 0/ analog input enabled | Hi-Z/ internal input fixed at 0/ analog input enabled | Hi-Z/ internal input fixed at 0/ analog input enabled | Hi-Z/ internal input fixed at 0/ analog input enabled | Hi-Z/ internal input fixed at 0/ analog input enabled | Hi-Z/ internal input fixed at 0/ analog input enabled | Hi-Z/ internal input fixed at 0/ analog input enabled | Hi-Z/ internal input fixed at 0/ analog input enabled |
| | Resource other than above selected GPIO selected | Setting disabled | Setting disabled | Setting disabled | Maintain previous state | Maintain previous state | Hi-Z/internal input fixed at 0 | GPIO selected, internal input fixed at 0 | Hi-Z/internal input fixed at 0 | GPIO selected |
| M | Analog input selected | Hi-Z | Hi-Z/ internal input fixed at 0/ analog input enabled | Hi-Z/ internal input fixed at 0/ analog input enabled | Hi-Z/ internal input fixed at 0/ analog input enabled | Hi-Z/ internal input fixed at 0/ analog input enabled | Hi-Z/ internal input fixed at 0/ analog input enabled | Hi-Z/ internal input fixed at 0/ analog input enabled | Hi-Z/ internal input fixed at 0/ analog input enabled | Hi-Z/ internal input fixed at 0/ analog input enabled |
| | External interrupt enable selected | Setting disabled | Setting disabled | Setting disabled | Maintain previous state | Maintain previous state | Maintain previous state | GPIO selected, internal input fixed at 0 | Hi-Z/internal input fixed at 0 | GPIO selected |
| | Resource other than above selected GPIO selected | | | | | | Hi-Z/internal input fixed at 0 | | | |
| N | Analog input selected | Hi-Z | Hi-Z/ internal input fixed at 0/ analog input enabled | Hi-Z/ internal input fixed at 0/ analog input enabled | Hi-Z/ internal input fixed at 0/ analog input enabled | Hi-Z/ internal input fixed at 0/ analog input enabled | Hi-Z/ internal input fixed at 0/ analog input enabled | Hi-Z/ internal input fixed at 0/ analog input enabled | Hi-Z/ internal input fixed at 0/ analog input enabled | Hi-Z/ internal input fixed at 0/ analog input enabled |
| | Trace selected | Setting disabled | Setting disabled | Setting disabled | Maintain previous state | Maintain previous state | Trace output | GPIO selected, internal input fixed at 0 | Hi-Z/internal input fixed at 0 | GPIO selected |
| | Resource other than above selected GPIO selected | | | | | | Hi-Z/internal input fixed at 0 | | | |
| O | Analog input selected | Hi-Z | Hi-Z/ internal input fixed | Hi-Z/ internal input fixed | Hi-Z/ internal input fixed at 0/ | Hi-Z/ internal input fixed at 0/ | Hi-Z/ internal input fixed at 0/ | Hi-Z/ internal input fixed at 0/ | Hi-Z/ internal input fixed at 0/ | Hi-Z/ internal input fixed at 0/ |

| Pin Status Type | Function Group | Power-On Reset or Low-Voltage Detection State | INITX Input State | Device Internal Reset State | Run mode or Sleep mode State | Timer mode, RTC mode, or Stop mode State | | Deep Standby RTC mode or Deep Standby Stop mode State | | Return from Deep Standby mode State |
|-----------------|------------------------------------|---|---|---|---|---|---|---|---|---|
| | | Power Supply Unstable | Power Supply Stable | | Power Supply Stable | Power Supply Stable | | Power Supply Stable | | Power Supply Stable |
| | | - | INITX=0 | INITX=1 | INITX=1 | INITX=1 | | INITX=1 | | INITX=1 |
| | | - | - | - | - | SPL=0 | SPL=1 | SPL=0 | SPL=1 | - |
| | | | at 0/ analog input enabled | at 0/ analog input enabled | analog input enabled | analog input enabled | analog input enabled | analog input enabled | analog input enabled | analog input enabled |
| | Trace selected | Setting disabled | Setting disabled | Setting disabled | Maintain previous state | Maintain previous state | Trace output | GPIO selected, internal input fixed at 0 | Hi-Z/internal input fixed at 0 | GPIO selected |
| | External interrupt enable selected | | | | | | Maintain previous state | | | |
| | Resource other than above selected | | | | | | Hi-Z/internal input fixed at 0 | | | |
| | GPIO selected | | | | | | | | | |
| P | Analog input selected | Hi-Z | Hi-Z/ internal input fixed at 0/ analog input enabled | Hi-Z/ internal input fixed at 0/ analog input enabled | Hi-Z/ internal input fixed at 0/ analog input enabled | Hi-Z/ internal input fixed at 0/ analog input enabled | Hi-Z/ internal input fixed at 0/ analog input enabled | Hi-Z/ internal input fixed at 0/ analog input enabled | Hi-Z/ internal input fixed at 0/ analog input enabled | Hi-Z/ internal input fixed at 0/ analog input enabled |
| | WKUP enabled | Setting disabled | Setting disabled | Setting disabled | Maintain previous state | Maintain previous state | Maintain previous state | WKUP input enabled | Hi-Z/ WKUP input enabled | GPIO selected |
| | Resource other than above selected | | | | | | Hi-Z/internal input fixed at 0 | Hi-Z/internal input fixed at 0 | | |
| GPIO selected | | | | | | | | | | |
| Q | WKUP enabled | Setting disabled | Setting disabled | Setting disabled | Maintain previous state | Maintain previous state | Maintain previous state | WKUP input enabled | Hi-Z/ WKUP input enabled | WKUP input enabled |
| | External interrupt enable selected | | | | | | | GPIO selected, internal input fixed at 0 | Hi-Z/internal input fixed at 0 | |
| | Resource other than above selected | Hi-Z | Hi-Z/ input enabled | Hi-Z/ input enabled | | | Hi-Z/internal input fixed at 0 | | GPIO selected | |
| | GPIO selected | | | | | | | | | |

| Pin Status Type | Function Group | Power-On Reset or Low-Voltage Detection State | INITX Input State | Device Internal Reset State | Run mode or Sleep mode State | Timer mode, RTC mode, or Stop mode State | | Deep Standby RTC mode or Deep Standby Stop mode State | | Return from Deep Standby mode State |
|-----------------|---|---|---------------------|-----------------------------|---|---|---|---|--------------------------------|-------------------------------------|
| | | Power Supply Unstable | Power Supply Stable | | Power Supply Stable | Power Supply Stable | | Power Supply Stable | | Power Supply Stable |
| | | - | INITX=0 | INITX=1 | INITX=1 | INITX=1 | | INITX=1 | | INITX=1 |
| | | - | - | - | - | SPL=0 | SPL=1 | SPL=0 | SPL=1 | - |
| R | GPIO selected | Hi-Z | Hi-Z/ input enabled | Hi-Z/ input enabled | Maintain previous state | Maintain previous state | Hi-Z/internal input fixed at 0 | GPIO selected, internal input fixed at 0 | Hi-Z/internal input fixed at 0 | GPIO selected |
| | USB I/O pin | Setting disabled | Setting disabled | Setting disabled | Hi-Z at transmission/ input enabled/ internal input fixed at 0 at reception | Hi-Z at transmission/ input enabled/ internal input fixed at 0 at reception | Hi-Z at transmission/ input enabled/ internal input fixed at 0 at reception | Hi-Z/ input enabled | Hi-Z/ input enabled | Hi-Z/ input enabled |
| V | Ethernet I/O selected *4 | Setting disabled | Setting disabled | Setting disabled | Maintain previous state | Maintain previous state | Maintain previous state | GPIO selected, internal input fixed at 0 | Hi-Z/internal input fixed at 0 | GPIO selected |
| | Resource other than above selected | Hi-Z | Hi-Z/ input enabled | Hi-Z/ input enabled | | | Hi-Z/internal input fixed at 0 | | | |
| | GPIO selected | | | | | | | | | |
| W | Ethernet input/output selected ⁴ | Setting disabled | Setting disabled | Setting disabled | Maintain previous state | Maintain previous state | Maintain previous state | GPIO selected, internal input fixed at 0 | Hi-Z/internal input fixed at 0 | GPIO selected |
| | External interrupt enable selected | | | | | | Hi-Z/internal input fixed at 0 | | | |
| | Resource other than above selected | Hi-Z | Hi-Z/ input enabled | Hi-Z/ input enabled | | | Hi-Z/internal input fixed at 0 | | | |
| | GPIO selected | | | | | | | | | |

- 1: Oscillation is stopped at Sub Timer mode, sub CR Timer mode, RTC mode, Stop mode, Deep Standby RTC mode, and Deep Standby Stop mode.
- 2: Maintain previous state at Timer mode. GPIO selected internal input fixed at 0 at RTC mode, Stop mode.
- 3: Maintain previous state at Timer mode. Hi-Z/internal input fixed at 0 at RTC mode, Stop mode.
- 4: It shows the case selected by EPFR14.E_SPLC register.

12. Electrical Characteristics

12.1 Absolute Maximum Ratings

| Parameter | Symbol | Rating | | Unit | Remarks |
|--|---------------------|-----------------------|--|------|-------------------------------------|
| | | Min | Max | | |
| Power supply voltage ^{*1,*2} | V _{CC} | V _{SS} - 0.5 | V _{SS} + 6.5 | V | |
| Power supply voltage (for USB) ^{*1,*3} | USBV _{CC0} | V _{SS} - 0.5 | V _{SS} + 6.5 | V | |
| Power supply voltage (for USB) ^{*1,*3} | USBV _{CC1} | V _{SS} - 0.5 | V _{SS} + 6.5 | V | |
| Power supply voltage (for Ethernet-MAC) ^{*1,*4} | ETHV _{CC} | V _{SS} - 0.5 | V _{SS} + 6.5 | V | |
| Analog power supply voltage ^{*1,*5} | AV _{CC} | V _{SS} - 0.5 | V _{SS} + 6.5 | V | |
| Analog reference voltage ^{1,5} | AVRH | V _{SS} - 0.5 | V _{SS} + 6.5 | V | |
| Input voltage ^{*1} | V _I | V _{SS} - 0.5 | V _{CC} + 0.5 (≤ 6.5 V) | V | Except for USB and Ethernet-MAC pin |
| | | V _{SS} - 0.5 | USBV _{CC0} + 0.5 (≤ 6.5 V) | V | USB ch 0 pin |
| | | V _{SS} - 0.5 | USBV _{CC1} + 0.5 (≤ 6.5 V) | V | USB ch 1 pin |
| | | V _{SS} - 0.5 | ETHV _{CC} + 0.5 (≤ 6.5 V) | V | Ethernet-MAC Pin |
| | | V _{SS} - 0.5 | V _{SS} + 6.5 | V | 5 V tolerant |
| Analog pin input voltage ^{*1} | V _{IA} | V _{SS} - 0.5 | AV _{CC} + 0.5 (≤ 6.5 V) | V | |
| Output voltage ^{*1} | V _O | V _{SS} - 0.5 | V _{CC} + 0.5 (≤ 6.5 V) | V | |
| L level maximum output current ^{*6} | I _{OL} | - | 10 | mA | 4 mA type |
| | | | 20 | mA | 8 mA type |
| | | | 20 | mA | 12 mA type |
| | | | 22.4 | mA | I ² C Fm+ |
| L level average output current ^{*7} | I _{OLAV} | - | 4 | mA | 4 mA type |
| | | | 8 | mA | 8 mA type |
| | | | 12 | mA | 12 mA type |
| | | | 20 | mA | I ² C Fm+ |
| L level total maximum output current | ∑I _{OL} | - | 100 | mA | |
| L level total maximum output current ⁸ | ∑I _{OLAV} | - | 50 | mA | |
| H level maximum output current ^{*6} | I _{OH} | - | - 10 | mA | 4 mA type |
| | | | -20 | mA | 8 mA type |
| | | | - 20 | mA | 12 mA type |
| H level average output current ^{*7} | I _{OHAV} | - | - 4 | mA | 4 mA type |
| | | | -8 | mA | 8 mA type |
| | | | - 12 | mA | 12 mA type |
| H level total maximum output current | ∑I _{OH} | - | - 100 | mA | |
| H level total average output current ⁸ | ∑I _{OHAV} | - | - 50 | mA | |
| Storage temperature | T _{STG} | - 55 | + 150 | °C | |

1: These parameters are based on the condition that V_{SS} = AV_{SS} = 0.0 V.

2: V_{CC} must not drop below V_{SS} - 0.5 V.

3: USBV_{CC0}, USBV_{CC1} must not drop below V_{SS} - 0.5 V.

4: ETHV_{CC} must not drop below V_{SS} - 0.5 V.

5: Ensure that the voltage does not exceed V_{CC} + 0.5V, for example, when the power is turned on.

6: The maximum output current is defined as the value of the peak current flowing through any one of the corresponding pins.

7: The average output current is defined as the average current value flowing through any one of the corresponding pins for a 100-ms period.

8: The total average output current is defined as the average current value flowing through all of corresponding pins for a 100-ms period.

WARNING:

- Semiconductor devices may be permanently damaged by application of stress (including, without limitation, voltage, current or temperature) in excess of absolute maximum ratings. Do not exceed any of these ratings.

12.2 Recommended Operating Conditions

| Parameter | Symbol | Conditions | Value | | Unit | Remarks | |
|---|----------------------|----------------|-------------------|-------------------------|-------|------------------------------------|--|
| | | | Min | Max | | | |
| Power supply voltage | V _{CC} | - | 2.7 ^{*9} | 5.5 | V | | |
| Power supply voltage (for USB ch 0) | USBV _{CC0} | - | 3.0 | 3.6 (≤V _{CC}) | V | *1 | |
| | | | 2.7 | 5.5 (≤V _{CC}) | | *2 | |
| Power supply voltage (for USB ch 1) | USBV _{CC1} | - | 3.0 | 3.6 (≤V _{CC}) | V | *3 | |
| | | | 2.7 | 5.5 (≤V _{CC}) | | *4 | |
| Power supply voltage (for Ethernet-MAC) | ETHV _{CC} | - | 3.0 | 3.6 (≤V _{CC}) | V | *5 | |
| | | | 4.5 | 5.5 (≤V _{CC}) | | *5 | |
| | | | 2.7 | 5.5 (≤V _{CC}) | | *6 | |
| Analog power supply voltage | AV _{CC} | - | 2.7 | 5.5 | V | AV _{CC} = V _{CC} | |
| Analog reference voltage | AVRH | - | *8 | AV _{CC} | V | | |
| | AVRL | - | AV _{SS} | AV _{SS} | V | | |
| Operating temperature | Junction temperature | T _J | - | - 40 | + 125 | °C | |
| | Ambient temperature | T _A | - | - 40 | *7 | °C | |

- 1: When P81/UDP0 and P80/UDM0 pins are used as USB (UDP0, UDM0)
- 2: When P81/UDP0 and P80/UDM0 pins are used as GPIO (P81, P80)
- 3: When P83/UDP1 and P82/UDM1 pins are used as USB (UDP1, UDM1)
- 4: When P83/UDP1 and P82/UDM1 pins are used as GPIO (P83, P82)
- 5: When the pins in Ethernet-MAC Pins, except P6E/ADTG_5/SCK4_1/IC23_1/INT29_0/E_PPS pin, are used as Ethernet-MAC pin
- 6: When the pins in Ethernet-MAC Pins, except P6E/ADTG_5/SCK4_1/IC23_1/INT29_0/E_PPS pin, are used as Ethernet-MAC pin
- 7: The maximum temperature of the ambient temperature (T_A) can guarantee a range that does not exceed the junction temperature (T_J).

The calculation formula of the ambient temperature (T_A) is:

$$T_A (\text{Max}) = T_J (\text{Max}) - P_d (\text{Max}) \times \theta_{JA}$$

- P_d: Power dissipation (W)
- θ_{JA}: Package thermal resistance (°C/W)

$$P_d (\text{Max}) = V_{CC} \times I_{CC} (\text{Max}) + \sum (I_{OL} \times V_{OL}) + \sum ((V_{CC} - V_{OH}) \times (-I_{OH}))$$

- I_{OL}: L level output current
- I_{OH}: H level output current
- V_{OL}: L level output voltage
- V_{OH}: H level output voltage

- 8: The minimum value of analog reference voltage depends on the value of compare clock cycle (T_{ck}). See 12.5. 12-bit A/D Converter for the details.
- 9: For the voltage range between V_{CC}(min) and the low voltage detection reset (VDH), the MCU must be clocked from either the High-speed CR or the low-speed CR.

Package thermal resistance and maximum permissible power for each package are shown below. The operation is guaranteed maximum permissible power or less for semiconductor devices.

Table 12-1 Table for Package Thermal Resistance and Maximum Permissible Power

| Package | Printed Circuit Board | Thermal Resistance θ_{ja} ($^{\circ}\text{C}/\text{W}$) | Maximum Permissible Power (mW) | |
|--------------------------------|---------------------------|--|-------------------------------------|--------------------------------------|
| | | | $T_A = +85\text{ }^{\circ}\text{C}$ | $T_A = +105\text{ }^{\circ}\text{C}$ |
| FPT-144P-M08 (0.5-mm pitch) | Single-layered both sides | 48 | 833 | 417 |
| | 4 layers | 33 | 1212 | 606 |
| FPT-176P-M07 (0.5-mm pitch) | Single-layered both sides | 45 | 889 | 444 |
| | 4 layers | 31 | 1290 | 645 |

WARNING:

- *The recommended operating conditions are required in order to ensure the normal operation of the semiconductor device. All of the device's electrical characteristics are warranted when the device is operated within these ranges. Always use semiconductor devices within their recommended operating condition ranges. Operation outside these ranges may adversely affect reliability and could result in device failure.*
- *No warranty is made with respect to uses, operating conditions, or combinations not represented on the data sheet. Users considering application outside the listed conditions are advised to contact their representatives beforehand.*

Ethernet-MAC Pins

| Pin Name | Ethernet-MAC Function | Except For Ethernet-MAC Function | Power Supply Type |
|---------------------------------|-----------------------|----------------------------------|--------------------|
| P6E/ADTG_5/SCK4_1/INT29_0/E_PPS | E_PPS * | P6E/ADTG_5/SCK4_1/INT29_0 | V _{CC} |
| PC0/E_RXER | E_RXER | PC0 | ETHV _{CC} |
| PC1/TIOB6_0/E_RX03 | E_RX03 | PC1/TIOB6_0 | |
| PC2/TIOA6_0/E_RX02 | E_RX02 | PC2/TIOA6_0 | |
| PC3/TIOB7_0/E_RX01 | E_RX01 | PC3/TIOB7_0 | |
| PC4/TIOA7_0/E_RX00 | E_RX00 | PC4/TIOA7_0 | |
| PC5/TIOB14_0/E_RXDV | E_RXDV | PC5/TIOB14_0 | |
| PC6/TIOA14_0/E_MDIO | E_MDIO | PC6/TIOA14_0 | |
| PC7/INT13_0/E_MDC/CROUT_1 | E_MDC | PC7/INT13_0/CROUT_1 | |
| PC8/E_RXCK_REFCK | E_RXCK_REFCK | PC8 | |
| PC9/TIOB15_0/E_COL | E_COL | PC9/TIOB15_0 | |
| PCA/TIOA15_0/E_CRS | E_CRS | PCA/TIOA15_0 | |
| PCB/INT28_0/E_COUT | E_COUT | PCB/INT28_0 | |
| PCC/E_TCK | E_TCK | PCC | |
| PCD/SOT4_1/INT14_0/E_TXER | E_TXER | PCD/SOT4_1/INT14_0 | |
| PCE/SIN4_1/INT15_0/E_TX03 | E_TX03 | PCE/SIN4_1/INT15_0 | |
| PCF/RTS4_1/INT12_0/E_TX02 | E_TX02 | PCF/RTS4_1/INT12_0 | |
| PD0/INT30_1/E_TX01 | E_TX01 | PD0/INT30_1 | |
| PD1/INT31_1/E_TX00 | E_TX00 | PD1/INT31_1 | |
| PD2/CTS4_1/E_TXEN | E_TXEN | PD2/CTS4_1 | |

*: It is used to confirm the PTP counter cycle in Ethernet-MAC by waveforms.

Calculation Method of Power Dissipation (Pd)

The power dissipation is shown in the following formula.

$$Pd = V_{CC} \times I_{CC} + \sum (I_{OL} \times V_{OL}) + \sum ((V_{CC}-V_{OH}) \times (-I_{OH}))$$

- I_{OL}: L level output current
- I_{OH}: H level output current
- V_{OL}: L level output voltage
- V_{OH}: H level output voltage

I_{CC} is the current drawn by the device.
It can be analyzed as follows.

$$I_{CC} = I_{CC} (INT) + \sum I_{CC} (IO)$$

I_{CC} (INT): Current drawn by internal logic and memory, etc. through the regulator

∑I_{CC} (IO): Sum of current (I/O switching current) drawn by the output pin

For I_{CC} (INT), it can be anticipated by "(1) Current Rating" in "12.3. DC Characteristics" (This rating value does not include I_{CC} (IO) for a value at pin fixed).

For I_{CC} (IO), it depends on system used by customers.

The calculation formula is shown below.

$$I_{CC} (IO) = (C_{INT} + C_{EXT}) \times V_{CC} \times f_{SW}$$

- C_{INT}: Pin internal load capacitance
- C_{EXT}: External load capacitance of output pin
- f_{SW}: Pin switching frequency

| Parameter | Symbol | Conditions | Capacitance Value |
|-------------------------------|------------------|------------|-------------------|
| Pin internal load capacitance | C _{INT} | 4 mA type | 1.93 pF |
| | | 8 mA type | 3.45 pF |
| | | 12 mA type | 3.42 pF |

Calculate I_{CC} (Max) as follows when the power dissipation can be evaluated by yourself:

Measure current value I_{CC} (Typ) at normal temperature (+25°C).

Add maximum leakage current value I_{CC} (leak_max) at operating on a value in (1).

$$I_{CC}(Max) = I_{CC} (Typ) + I_{CC} (leak_max)$$

| Parameter | Symbol | Conditions | Current Value |
|--------------------------------------|----------------------------|--------------------------|---------------|
| Maximum leakage current at operating | I _{CC} (leak_max) | T _J = +125 °C | TBD |
| | | T _J = +105 °C | TBD |
| | | T _J = +85 °C | TBD |

12.3 DC Characteristics

12.3.1 Current Rating

Table 12-2 Typical and Maximum Current Consumption in Normal Operation (PLL), Code Running from Flash Memory (Flash Accelerator Mode and Trace Buffer Function Enabled)

| Parameter | Symbol | Pin Name | Conditions | Frequency* ⁴ | Value | | Unit | Remarks |
|----------------------|-----------------|-----------------|------------------------------|-------------------------|-------------------|-------------------|------|--|
| | | | | | Typ* ¹ | Max* ² | | |
| Power supply current | I _{CC} | V _{CC} | Normal operation *7,*8 (PLL) | *5 | 180 MHz | 73 | TBD | *3 When all peripheral clocks are on |
| | | | | *6 | 160 MHz | 65 | TBD | |
| | | | | | 144 MHz | 59 | TBD | |
| | | | | | 120 MHz | 50 | TBD | |
| | | | | | 100 MHz | 43 | TBD | |
| | | | | | 80 MHz | 35 | TBD | |
| | | | | | 60 MHz | 27 | TBD | |
| | | | | | 40 MHz | 19 | TBD | |
| | | | | | 20 MHz | 11 | TBD | |
| | | | | 8 MHz | 6.9 | TBD | | |
| | | | | 4 MHz | 5.3 | TBD | | |
| | | | | *5 | 180 MHz | 44 | TBD | *3 When all peripheral clocks are off |
| | | | | *6 | 160 MHz | 40 | TBD | |
| | | | | | 144 MHz | 36 | TBD | |
| | | | | | 120 MHz | 31 | TBD | |
| | | | | | 100 MHz | 27 | TBD | |
| | | | | | 80 MHz | 22 | TBD | |
| | | | | | 60 MHz | 17 | TBD | |
| 40 MHz | 13 | TBD | | | | | | |
| 20 MHz | 7.9 | TBD | | | | | | |
| 8 MHz | 5.2 | TBD | | | | | | |
| 4 MHz | 4.3 | TBD | | | | | | |

1: T_A = +25 °C, V_{CC} = 3.3 V

2: T_J = +125 °C, V_{CC} = 5.5 V

3: When all ports are fixed

4: Frequency is a value of HCLK when PCLK0 = PCLK1 = PCLK2 = HCLK/2

5: When stopping flash accelerator mode and trace buffer function (FRWTR.RWT = 11, FBFCR.BE = 1)

6: When stopping flash accelerator mode and trace buffer function (FRWTR.RWT = 10, FBFCR.BE = 1)

7: Firmware being executed during data collection for this table is not being accessed from the MainFlash memory.”

8: When using the crystal oscillator of 4 MHz (including the current consumption of the oscillation circuit)

Table 14-2 Typical and Maximum Current Consumption in Normal Operation (PLL), Code with Data Accessing Running from Flash Memory (Flash Accelerator Mode and Trace Buffer Function Disabled)

| Parameter | Symbol | Pin Name | Conditions | Frequency* ⁴ | Value | | Unit | Remarks | |
|----------------------|-----------------|-----------------|------------------------------|-------------------------|-------------------|-------------------|------|---------|--|
| | | | | | Typ* ¹ | Max* ² | | | |
| Power supply current | I _{CC} | V _{CC} | Normal operation *7,*8 (PLL) | *5 | 180 MHz | 82 | TBD | mA | *3 When all peripheral clocks are on |
| | | | | *6 | 160 MHz | 74 | TBD | mA | |
| | | | | | 144 MHz | 68 | TBD | mA | |
| | | | | | 120 MHz | 58 | TBD | mA | |
| | | | | | 100 MHz | 49 | TBD | mA | |
| | | | | | 80 MHz | 40 | TBD | mA | |
| | | | | | 60 MHz | 31 | TBD | mA | |
| | | | | | 40 MHz | 22 | TBD | mA | |
| | | | | | 20 MHz | 13 | TBD | mA | |
| | | | | 8 MHz | 7.5 | TBD | mA | | |
| | | | | 4 MHz | 5.6 | TBD | mA | | |
| | | | | *5 | 180 MHz | 48 | TBD | mA | *3 When all peripheral clocks are off |
| | | | | *6 | 160 MHz | 44 | TBD | mA | |
| | | | | | 144 MHz | 41 | TBD | mA | |
| | | | | | 120 MHz | 35 | TBD | mA | |
| | | | | | 100 MHz | 30 | TBD | mA | |
| | | | | | 80 MHz | 25 | TBD | mA | |
| | | | | | 60 MHz | 20 | TBD | mA | |
| 40 MHz | 14 | TBD | mA | | | | | | |
| 20 MHz | 8.7 | TBD | mA | | | | | | |
| 8 MHz | 5.6 | TBD | mA | | | | | | |
| 4 MHz | 4.5 | TBD | mA | | | | | | |

1: T_A = +25 °C, V_{CC} = 3.3 V

2: T_J = +125 °C, V_{CC} = 5.5 V

3: When all ports are fixed

4: Frequency is a value of HCLK when PCLK0 = PCLK1 = PCLK2 = HCLK

5: When stopping flash accelerator mode and trace buffer function (FRWTR.RWT = 11, FBFCR.BE = 0)

6: When stopping flash accelerator mode and trace buffer function (FRWTR.RWT = 10, FBFCR.BE = 0)

7: With data access to a MainFlash memory.

8: When using the crystal oscillator of 4 MHz (including the current consumption of the oscillation circuit)

Table 12-3 Typical and Maximum Current Consumption in Normal Operation (PLL), Code with Data Accessing Running from Flash Memory (Flash 0 Wait-Cycle Mode and Read Access 0 Wait)

| Parameter | Symbol | Pin Name | Conditions | Frequency* ⁴ | Value | | Unit | Remarks |
|----------------------|-----------------|----------|------------------------------|-------------------------|-------------------|-------------------|------|--|
| | | | | | Typ* ¹ | Max* ² | | |
| Power supply current | I _{CC} | VCC | Normal operation *6,*7 (PLL) | *5 | 72 MHz | 54 | TBD | *3 When all peripheral clocks are on |
| | | | | | 60 MHz | 47 | TBD | |
| | | | | | 48 MHz | 39 | TBD | |
| | | | | | 36 MHz | 31 | TBD | |
| | | | | | 24 MHz | 23 | TBD | |
| | | | | | 12 MHz | 14 | TBD | |
| | | | | | 8 MHz | 11 | TBD | |
| | | | | *5 | 72 MHz | 37 | TBD | *3 When all peripheral clocks are off |
| | | | | | 60 MHz | 33 | TBD | |
| | | | | | 48 MHz | 28 | TBD | |
| | | | | | 36 MHz | 23 | TBD | |
| | | | | | 24 MHz | 17 | TBD | |
| | | | | | 12 MHz | 11 | TBD | |
| | | | | | 8 MHz | 8.3 | TBD | |
| 4 MHz | 5.9 | TBD | | | | | | |

1: T_A = +25 °C, V_{CC} = 3.3 V

2: T_J = +125 °C, V_{CC} = 5.5 V

3: When all ports are fixed

4: Frequency is a value of HCLK when PCLK0 = PCLK1 = PCLK2 = HCLK

5: When operating flash 0 wait-cycle mode and read access 0 wait (FRWTR.RWT = 00, FBFCR.SD = 000)

6: With data access to a MainFlash memory.

7: When using the crystal oscillator of 4 MHz (including the current consumption of the oscillation circuit)

Table 12-4 Typical and Maximum Current Consumption in Normal Operation (Other than PLL), Code with Data Accessing Running from Flash Memory (Flash 0 Wait-Cycle Mode and Read Access 0 Wait)

| Parameter | Symbol | Pin Name | Conditions | Frequency* ⁴ | Value | | Unit | Remarks | |
|----------------------|-----------------|-----------------|---|-------------------------|-------------------|-------------------|------|---------|--|
| | | | | | Typ* ¹ | Max* ² | | | |
| Power supply current | I _{CC} | V _{CC} | Normal operation * ⁶ , * ⁷ (main oscillation) | * ⁵ | 4 MHz | 4.3 | TBD | mA | * ³ When all peripheral clocks are on |
| | | | | | | 3.7 | TBD | mA | * ³ When all peripheral clocks are off |
| | | | Normal operation * ⁶ (built-in High-speed CR) | * ⁵ | 4 MHz | 3.5 | TBD | mA | * ³ When all peripheral clocks are on |
| | | | | | | 2.9 | TBD | mA | * ³ When all peripheral clocks are off |
| | | | Normal operation * ⁶ , * ⁸ (sub oscillation) | * ⁵ | 32 kHz | 0.47 | TBD | mA | * ³ When all peripheral clocks are on |
| | | | | | | 0.46 | TBD | mA | * ³ When all peripheral clocks are off |
| | | | Normal operation * ⁶ (built-in low-speed CR) | * ⁵ | 100 kHz | 0.51 | TBD | mA | * ³ When all peripheral clocks are on |
| | | | | | | 0.50 | TBD | mA | * ³ When all peripheral clocks are off |

1: T_A = +25 °C, V_{CC} = 3.3 V

2: T_J = +125 °C, V_{CC} = 5.5 V

3: When all ports are fixed

4: Frequency is a value of HCLK when PCLK0 = PCLK1 = PCLK2 = HCLK/2

5: When operating flash 0 wait-cycle mode and read access 0 wait (FRWTR.RWT = 00, FBFCR.SD = 000)

6: With data access to a MainFlash memory.

7: When using the crystal oscillator of 4 MHz (including the current consumption of the oscillation circuit)

8: When using the crystal oscillator of 32 kHz (including the current consumption of the oscillation circuit)

Table 12-5 Typical and Maximum Current Consumption in Sleep Operation (PLL), when PCLK0 = PCLK1 = PCLK2 = HCLK/2

| Parameter | Symbol | Pin Name | Conditions | Frequency* ⁴ | Value | | Unit | Remarks |
|----------------------|------------------|----------|---|-------------------------|-------------------|-------------------|------|--|
| | | | | | Typ* ¹ | Max* ² | | |
| Power supply current | I _{CCS} | VCC | Sleep operation * ⁵ (PLL) | 180 MHz | 58 | TBD | mA | * ³ When all peripheral clocks are on |
| | | | | 160 MHz | 52 | TBD | mA | |
| | | | | 144 MHz | 48 | TBD | mA | |
| | | | | 120 MHz | 40 | TBD | mA | |
| | | | | 100 MHz | 35 | TBD | mA | |
| | | | | 80 MHz | 28 | TBD | mA | |
| | | | | 60 MHz | 22 | TBD | mA | |
| | | | | 40 MHz | 16 | TBD | mA | |
| | | | | 20 MHz | 9.7 | TBD | mA | |
| | | | | 8 MHz | 6.2 | TBD | mA | |
| | | | | 4 MHz | 5.0 | TBD | mA | |
| | | | | 180 MHz | 30 | TBD | mA | * ³ When all peripheral clocks are off |
| | | | | 160 MHz | 27 | TBD | mA | |
| | | | | 144 MHz | 25 | TBD | mA | |
| | | | | 120 MHz | 21 | TBD | mA | |
| | | | | 100 MHz | 18 | TBD | mA | |
| | | | | 80 MHz | 15 | TBD | mA | |
| | | | | 60 MHz | 12 | TBD | mA | |
| | | | | 40 MHz | 9.3 | TBD | mA | |
| | | | | 20 MHz | 6.2 | TBD | mA | |
| 8 MHz | 4.5 | TBD | mA | | | | | |
| 4 MHz | 4.0 | TBD | mA | | | | | |

1: T_A = +25 °C, V_{CC} = 3.3 V

2: T_J = +125 °C, V_{CC} = 5.5 V

3: When all ports are fixed

4: Frequency is a value of HCLK when PCLK0 = PCLK1 = PCLK2 = HCLK/2

5: When using the crystal oscillator of 4 MHz (including the current consumption of the oscillation circuit)

Table 12-6 Typical and Maximum Current Consumption in Sleep Operation (PLL), when PCLK0 = PCLK1 = PCLK2 = HCLK

| Parameter | Symbol | Pin Name | Conditions | Frequency* ⁴ | Value | | Unit | Remarks |
|----------------------|------------------|----------|-------------------------------------|-------------------------|-------------------|-------------------|------|--|
| | | | | | Typ* ¹ | Max* ² | | |
| Power supply current | I _{CCS} | VCC | Sleep operation* ⁵ (PLL) | 72 MHz | 32 | TBD | mA | * ³ When all peripheral clocks are on |
| | | | | 60 MHz | 27 | TBD | mA | |
| | | | | 48 MHz | 23 | TBD | mA | |
| | | | | 36 MHz | 18 | TBD | mA | |
| | | | | 24 MHz | 13 | TBD | mA | |
| | | | | 12 MHz | 8.5 | TBD | mA | |
| | | | | 8 MHz | 6.9 | TBD | mA | |
| | | | | 4 MHz | 5.3 | TBD | mA | |
| | | | | 72 MHz | 15 | TBD | mA | * ³ When all peripheral clocks are off |
| | | | | 60 MHz | 13 | TBD | mA | |
| | | | | 48 MHz | 11 | TBD | mA | |
| | | | | 36 MHz | 9.3 | TBD | mA | |
| | | | | 24 MHz | 7.3 | TBD | mA | |
| | | | | 12 MHz | 5.4 | TBD | mA | |
| | | | | 8 MHz | 4.7 | TBD | mA | |
| | | | | 4 MHz | 4.1 | TBD | mA | |

1: T_A = +25 °C, V_{CC} = 3.3 V

2: T_J = +125 °C, V_{CC} = 5.5 V

3: When all ports are fixed

4: Frequency is a value of HCLK when PCLK0 = PCLK1 = PCLK2 = HCLK

5: When using the crystal oscillator of 4 MHz (including the current consumption of the oscillation circuit)

Table 12-7 Typical and Maximum Current Consumption in Sleep Operation (Other than PLL), when PCLK0 = PCLK1 = PCLK2 = HCLK/2

| Parameter | Symbol | Pin Name | Conditions | Frequency* ⁴ | Value | | Unit | Remarks |
|----------------------|------------------|----------|--|-------------------------|-------------------|-------------------|------|--|
| | | | | | Typ* ¹ | Max* ² | | |
| Power supply current | I _{CCS} | VCC | Sleep operation * ⁵ (main oscillation) | 4 MHz | 2.6 | TBD | mA | * ³ When all peripheral clocks are on |
| | | | | | 2.0 | TBD | mA | * ³ When all peripheral clocks are off |
| | | | Sleep operation (built-in High-speed CR) | 4 MHz | 2.0 | TBD | mA | * ³ When all peripheral clocks are on |
| | | | | | 1.3 | TBD | mA | * ³ When all peripheral clocks are off |
| | | | Sleep operation * ⁶ (sub oscillation) | 32 kHz | 0.46 | TBD | mA | * ³ When all peripheral clocks are on |
| | | | | | 0.45 | TBD | mA | * ³ When all peripheral clocks are off |
| | | | Sleep operation (built-in low-speed CR) | 100 kHz | 0.47 | TBD | mA | * ³ When all peripheral clocks are on |
| | | | | | 0.46 | TBD | mA | * ³ When all peripheral clocks are off |

1: T_A = +25 °C, V_{CC} = 3.3 V

2: T_J = +125 °C, V_{CC} = 5.5 V

3: When all ports are fixed.

4: Frequency is a value of HCLK when PCLK0 = PCLK1 = PCLK2 = HCLK/2

5: When using the crystal oscillator of 4 MHz (including the current consumption of the oscillation circuit)

6: When using the crystal oscillator of 32 kHz (including the current consumption of the oscillation circuit)

Table 12-8 Typical and Maximum Current Consumption in Stop Mode, Timer Mode and RTC Mode

| Parameter | Symbol | Pin Name | Conditions | Frequency | Value | | Unit | Remarks |
|----------------------|---|-----------------|--|-----------|-------------------|--|--|--|
| | | | | | Typ ^{*1} | Max ^{*2} | | |
| Power supply current | I _{CCH} | V _{CC} | Stop mode | - | 0.41 | TBD | mA | ^{*3, *4} T _A = +25°C |
| | | | | | - | TBD | mA | ^{*3, *4} T _A = +85°C |
| | | | | | - | TBD | mA | ^{*3, *4} T _A = +105°C |
| | I _{CCT} | | Timer mode ^{*5} (main oscillation) | 4 MHz | 1.40 | TBD | mA | ^{*3, *4} T _A = +25°C |
| | | | | | - | TBD | mA | ^{*3, *4} T _A = +85°C |
| | | | | | - | TBD | mA | ^{*3, *4} T _A = +105°C |
| | | | Timer mode (built-in High-speed CR) | 4 MHz | 0.71 | TBD | mA | ^{*3, *4} T _A = +25°C |
| | | | | | - | TBD | mA | ^{*3, *4} T _A = +85°C |
| | | | | | - | TBD | mA | ^{*3, *4} T _A = +105°C |
| | | | Timer mode ^{*6} (sub oscillation) | 32 kHz | 0.41 | TBD | mA | ^{*3, *4} T _A = +25°C |
| | | | | | - | TBD | mA | ^{*3, *4} T _A = +85°C |
| | | | | | - | TBD | mA | ^{*3, *4} T _A = +105°C |
| | Timer mode (built-in low-speed CR) | | 100 kHz | 0.42 | TBD | mA | ^{*3, *4} T _A = +25°C | |
| | | | | - | TBD | mA | ^{*3, *4} T _A = +85°C | |
| | | | | - | TBD | mA | ^{*3, *4} T _A = +105°C | |
| I _{CCR} | RTC mode ^{*6} (sub oscillation) | 32 kHz | 0.42 | TBD | mA | ^{*3, *4} T _A = +25°C | | |
| | | | - | TBD | mA | ^{*3, *4} T _A = +85°C | | |
| | | | - | TBD | mA | ^{*3, *4} T _A = +105°C | | |

1: V_{CC} = 3.3 V

2: V_{CC} = 5.5 V

3: When all ports are fixed

4: When LVD is off

5: When using the crystal oscillator of 4 MHz (including the current consumption of the oscillation circuit)

6: When using the crystal oscillator of 32 kHz (including the current consumption of the oscillation circuit)

Table 12-9 Typical and Maximum Current Consumption in Deep Standby Stop Mode, Deep Standby RTC Mode

| Parameter | Symbol | Pin Name | Conditions | Frequency | Value | | Unit | Remarks |
|----------------------|-------------------|----------|---|-----------|-------------------|-------------------|------|-----------------------------------|
| | | | | | Typ* ¹ | Max* ² | | |
| Power supply current | I _{CCHD} | VCC | Deep standby Stop mode (When RAM is off) | - | 89 | TBD | μA | *3, *4 T _A = +25°C |
| | | | | | - | TBD | μA | *3, *4 T _A = +85°C |
| | | | | | - | TBD | μA | *3, *4 T _A = +105°C |
| | | | Deep standby Stop mode (When RAM is on) | - | 101 | TBD | μA | *3, *4 T _A = +25°C |
| | | | | | - | TBD | μA | *3, *4 T _A = +85°C |
| | | | | | - | TBD | μA | *3, *4 T _A = +105°C |
| | I _{CCRD} | VCC | Deep standby RTC mode* ⁶ (When RAM is off) | 32 kHz | 93 | TBD | μA | *3, *4 T _A = +25°C |
| | | | | | - | TBD | μA | *3, *4 T _A = +85°C |
| | | | | | - | TBD | μA | *3, *4 T _A = +105°C |
| | | | Deep standby RTC mode* ⁶ (When RAM is on) | 32 kHz | 105 | TBD | μA | *3, *4 T _A = +25°C |
| | | | | | - | TBD | μA | *3, *4 T _A = +85°C |
| | | | | | - | TBD | μA | *3, *4 T _A = +105°C |

1: V_{CC} = 3.3 V

2: V_{CC} = 5.5 V

3: When all ports are fixed

4: When LVD is off

5: When sub oscillation is off

6: When using the crystal oscillator of 32 kHz (including the current consumption of the oscillation circuit)

Table 12-10 Typical and Maximum Current Consumption in Low-voltage Detection Circuit, Main Flash Memory Write/Erase

| Parameter | Symbol | Pin Name | Conditions | Value | | | Unit | Remarks |
|--|----------------------|----------|----------------|-------|------|------|---------------|-----------------------------|
| | | | | Min | Typ | Max | | |
| Low-voltage detection circuit (LVD) power supply current | $I_{CC\text{LVD}}$ | VCC | At operation | - | 4 | 7 | μA | For occurrence of interrupt |
| MainFlash memory write/erase current | $I_{CC\text{FLASH}}$ | | At write/erase | - | 13.4 | 15.9 | mA | *1 |

1: When programming or erase in flash memory, Flash Memory Write/Erase current ($I_{CC\text{FLASH}}$) is added to the Power supply current (I_{CC}).

Peripheral Current Dissipation

| Clock System | Peripheral | Unit | Frequency (MHz) | | | Unit | Remarks |
|--------------|--|-------------|-----------------|------|------|------|---------|
| | | | 45 | 90 | 180 | | |
| HCLK | GPIO | All ports | 0.69 | 1.39 | 2.76 | mA | |
| | DMAC | - | 0.74 | 1.46 | 2.83 | | |
| | DSTC | - | 0.58 | 1.13 | 2.12 | | |
| | External bus I/F | - | 0.23 | 0.44 | 0.87 | | |
| | SD card I/F | - | 0.56 | 1.10 | 2.18 | | |
| | CAN | 1 ch | 0.09 | 0.10 | 0.12 | | |
| | USB | 1 ch | 0.41 | 0.83 | 1.64 | | |
| | Ethernet-MAC | - | 1.52 | 2.97 | 5.84 | | |
| PCLK1 | Base timer | 4 ch | 0.38 | 0.76 | 1.50 | mA | |
| | Multi-functional timer/PPG | 1 unit/4 ch | 0.72 | 1.43 | 2.83 | | |
| | Quadrature position/revolution counter | 1 unit | 0.06 | 0.12 | 0.22 | | |
| | A/D converter | 1 unit | 0.31 | 0.61 | 1.22 | | |
| PCLK2 | Multi-function serial | 1 ch | 0.36 | 0.72 | - | mA | |
| | IC Card Interface | 1 ch | 0.27 | 0.54 | - | | |
| | I2S clock generator | 1 ch | 0.26 | 0.53 | - | | |

12.3.2 Pin Characteristics

($V_{CC} = USBV_{CC0} = USBV_{CC1} = ETHV_{CC} = AV_{CC} = 2.7V$ to $5.5V$, $V_{SS} = AV_{SS} = 0V$)

| Parameter | Symbol | Pin Name | Conditions | Value | | | Unit | Remarks |
|--|---|---|---|------------------------|-----|------------------------|------|-----------------|
| | | | | Min | Typ | Max | | |
| H level input voltage (hysteresis input) | V_{IHS} | CMOS hysteresis input pin, MD0, MD1 | - | $V_{CC} \times 0.8$ | - | $V_{CC} + 0.3$ | V | At External Bus |
| | | | | $ETHV_{CC} \times 0.8$ | - | $ETHV_{CC} + 0.3$ | V | |
| | | MADATA _{xx} | $V_{CC} > 3.0 V$, $V_{CC} \leq 3.6 V$, | 2.4 | - | $V_{CC} + 0.3$ | V | |
| | | 5V tolerant input pin | - | $V_{CC} \times 0.8$ | - | $V_{SS} + 5.5$ | V | |
| | | Input pin doubled as I ² C Fm+ | - | $V_{CC} \times 0.7$ | - | $V_{SS} + 5.5$ | V | |
| | | TTL Schmitt input pin | - | 2.0 | - | $ETHV_{CC} + 0.3$ | V | |
| L level input voltage (hysteresis input) | V_{ILS} | CMOS hysteresis input pin, MD0, MD1 | - | $V_{SS} - 0.3$ | - | $V_{CC} \times 0.2$ | V | |
| | | | | $V_{SS} - 0.3$ | - | $ETHV_{CC} \times 0.2$ | V | |
| | | 5V tolerant input pin | - | $V_{SS} - 0.3$ | - | $V_{CC} \times 0.2$ | V | |
| | | Input pin doubled as I ² C Fm+ | - | V_{SS} | - | $V_{CC} \times 0.3$ | V | |
| | | TTL Schmitt input pin | - | $V_{SS} - 0.3$ | - | 0.8 | V | |
| H level output voltage | V_{OH} | 4 mA type | $V_{CC} \geq 4.5 V$, $I_{OH} = -4 mA$ | $V_{CC} - 0.5$ | - | V_{CC} | V | |
| | | | $V_{CC} < 4.5 V$, $I_{OH} = -2 mA$ | | | | | |
| | | | $ETHV_{CC} \geq 4.5 V$, $I_{OH} = -4 mA$ | $V_{CC} - 0.5$ | - | $ETHV_{CC}$ | V | |
| | | | $ETHV_{CC} < 4.5 V$, $I_{OH} = -2 mA$ | | | | | |
| | | 8 mA type | $V_{CC} \geq 4.5 V$, $I_{OH} = -8 mA$ | $V_{CC} - 0.5$ | - | V_{CC} | V | |
| | | | $V_{CC} < 4.5 V$, $I_{OH} = -4 mA$ | | | | | |
| | | | $ETHV_{CC} \geq 4.5 V$, $I_{OH} = -8 mA$ | $ETHV_{CC} - 0.5$ | - | $ETHV_{CC}$ | V | |
| | | | $ETHV_{CC} < 4.5 V$, $I_{OH} = -4 mA$ | | | | | |
| | | 12 mA type | $V_{CC} \geq 4.5 V$, $I_{OH} = -12 mA$ | $V_{CC} - 0.5$ | - | V_{CC} | V | |
| | | | $V_{CC} < 4.5 V$, $I_{OH} = -8 mA$ | | | | | |
| | | The pin doubled as USB I/O | $USBV_{CC} \geq 4.5 V$, $I_{OH} = -20.5 mA$ | $USBV_{CC} - 0.4$ | - | $USBV_{CC}$ | V | *1 |
| | | | $USBV_{CC} < 4.5 V$, $I_{OH} = -13.0 mA$ | | | | | |
| The pin doubled as I ² C Fm+ | $V_{CC} \geq 4.5 V$, $I_{OH} = -4 mA$ | $V_{CC} - 0.5$ | - | V_{CC} | V | At GPIO | | |
| | $V_{CC} < 4.5 V$, $I_{OH} = -3 mA$ | | | | | | | |

| Parameter | Symbol | Pin Name | Conditions | Value | | | Unit | Remarks |
|---|-------------------------|---|--|-----------------|-----|-----|------|---------|
| | | | | Min | Typ | Max | | |
| L level output voltage | V _{OL} | 4 mA type | V _{CC} ≥ 4.5 V, I _{OL} = 4 mA | V _{SS} | - | 0.4 | V | |
| | | | V _{CC} < 4.5 V, I _{OL} = 2 mA | | | | | |
| | | | ETHV _{CC} ≥ 4.5 V, I _{OL} = 4 mA | V _{SS} | - | 0.4 | V | |
| | | | | | | | | |
| | | 8 mA type | V _{CC} ≥ 4.5 V, I _{OL} = 8 mA | V _{SS} | - | 0.4 | V | |
| | | | | | | | | |
| | | | ETHV _{CC} ≥ 4.5 V, I _{OL} = 8 mA | V _{SS} | - | 0.4 | V | |
| | | | | | | | | |
| | | 12 mA type | V _{CC} ≥ 4.5 V, I _{OL} = 12 mA | V _{SS} | - | 0.4 | V | |
| | | | V _{CC} < 4.5 V, I _{OL} = 8 mA | | | | | |
| | | The pin doubled as USB I/O | USBV _{CC} ≥ 4.5 V, I _{OL} = 18.5 mA | V _{SS} | - | 0.4 | V | *1 |
| | | | USBV _{CC} < 4.5 V, I _{OL} = 10.5 mA | | | | | |
| | | The pin doubled as I ² C Fm+ | V _{CC} ≥ 4.5 V, I _{OL} = 4 mA | V _{SS} | - | 0.4 | V | At GPIO |
| | | | V _{CC} < 4.5 V, I _{OL} = 3 mA | | | | | |
| V _{CC} ≤ 4.5 V, I _{OL} = 20 mA | At I ² C Fm+ | | | | | | | |
| Input leak current | I _{IL} | - | - | - 5 | - | + 5 | μA | |
| Pull-up resistor value | R _{PU} | Pull-up pin | V _{CC} ≥ 4.5 V | 25 | 50 | 100 | kΩ | |
| | | | V _{CC} < 4.5 V | 30 | 80 | 200 | | |
| Input capacitance | C _{IN} | Other than VCC, USBVCC0, USBVCC1, ETHVCC, VSS, AVCC, AVSS, AVRH | - | - | 5 | 15 | pF | |

1: USBV_{CC0} and USBV_{CC1} are described as USBV_{CC}.

12.4 AC Characteristics

12.4.1 Main Clock Input Characteristics

($V_{CC} = AV_{CC} = 2.7V$ to $5.5V$, $V_{SS} = AV_{SS} = 0V$, $T_A = -40^{\circ}C$ to $+105^{\circ}C$)

| Parameter | Symbol | Pin Name | Conditions | Value | | Unit | Remarks | |
|---|------------------------|-----------|---------------------|--|-----|------|--------------------------------------|---------------------------|
| | | | | Min | Max | | | |
| Input frequency | f_{CH} | X0, X1 | $V_{CC} \geq 4.5 V$ | 4 | 48 | MHz | When crystal oscillator is connected | |
| | | | $V_{CC} < 4.5 V$ | 4 | 20 | | | |
| | | | $V_{CC} \geq 4.5 V$ | 4 | 48 | MHz | When using external clock | |
| | | | $V_{CC} < 4.5 V$ | 4 | 20 | | | |
| Input clock cycle | t_{CYLH} | | $V_{CC} \geq 4.5 V$ | 20.83 | 250 | ns | When using external clock | |
| | | | $V_{CC} < 4.5 V$ | 50 | 250 | | | |
| Input clock pulse width | - | | | P_{WH}/t_{CYLH} , P_{WL}/t_{CYLH} | 45 | 55 | % | When using external clock |
| Input clock rise time and fall time | t_{CF} , t_{CR} | | | - | - | 5 | ns | When using external clock |
| | | | | | | | | |
| Internal operating clock ^{*1} frequency | f_{CC} | - | - | - | 180 | MHz | Base clock (HCLK/FCLK) | |
| | f_{CP0} | - | - | - | 90 | MHz | APB0bus clock ^{*2} | |
| | f_{CP1} | - | - | - | 180 | MHz | APB1bus clock ^{*2} | |
| | f_{CP2} | - | - | - | 90 | MHz | APB2bus clock ^{*2} | |
| Internal operating clock ^{*1} cycle time | t_{CYCC} | - | - | 5.56 | - | ns | Base clock (HCLK/FCLK) | |
| | t_{CYCP0} | - | - | 11.1 | - | ns | APB0bus clock ^{*2} | |
| | t_{CYCP1} | - | - | 5.56 | - | ns | APB1bus clock ^{*2} | |
| | t_{CYCP2} | - | - | 11.1 | - | ns | APB2bus clock ^{*2} | |

- 1: For more information about each internal operating clock, see Chapter 2-1: Clock in FM4 Family Peripheral Manual Main Part (MN709-00001).
- 2: For more about each APB bus to which each peripheral is connected, see 8. Block Diagram in this data sheet.

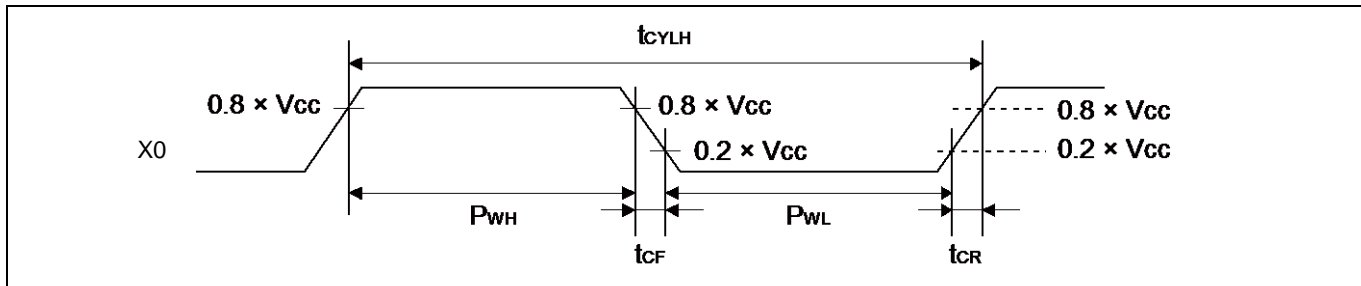

12.4.2 Sub Clock Input Characteristics

($V_{CC} = 2.7V$ to $5.5V$, $V_{SS} = 0V$)

| Parameter | Symbol | Pin Name | Conditions | Value | | | Unit | Remarks |
|-------------------------|--------------|-------------|--|-------|--------|-------|---------|--|
| | | | | Min | Typ | Max | | |
| Input frequency | $1/t_{CYLL}$ | X0A, X1A | - | - | 32.768 | - | kHz | When crystal oscillator is connected * |
| | | | - | 32 | - | 100 | | kHz |
| Input clock cycle | t_{CYLL} | | - | 10 | - | 31.25 | μs | When using external clock |
| Input clock pulse width | - | | P_{WH}/t_{CYLL} , P_{WL}/t_{CYLL} | 45 | - | 55 | % | When using external clock |

*: For more information about crystal oscillator, see Sub crystal oscillator in 7. Handling Devices.

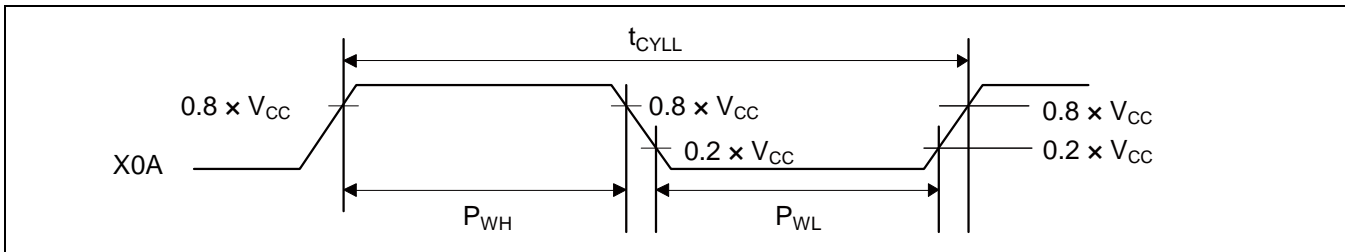

12.4.3 Built-In CR Oscillation Characteristics

Built-In High-speed CR

($V_{CC} = 2.7V$ to $5.5V$, $V_{SS} = 0V$)

| Parameter | Symbol | Conditions | Value | | | Unit | Remarks |
|------------------------------|------------|---|-------|-----|------|---------|-------------------|
| | | | Min | Typ | Max | | |
| Clock frequency | f_{CRH} | $T_J = -20^{\circ}C$ to $+105^{\circ}C$ | 3.92 | 4 | 4.08 | MHz | When trimming *1 |
| | | $T_J = -40^{\circ}C$ to $+125^{\circ}C$ | 3.88 | 4 | 4.12 | | When not trimming |
| | | $T_J = -40^{\circ}C$ to $+125^{\circ}C$ | 2.9 | 4 | 5 | | |
| Frequency stabilization time | t_{CRWT} | - | - | - | 30 | μs | *2 |

- 1: In the case of using the values in CR trimming area of flash memory at shipment for frequency/temperature trimming
- 2: This is the time to stabilize the frequency of the High-speed CR clock after setting trimming value. During this period, it is able to use the High-speed CR clock as a source clock.

Built-In Low-speed CR

($V_{CC} = 2.7V$ to $5.5V$, $V_{SS} = 0V$)

| Parameter | Symbol | Condition | Value | | | Unit | Remarks |
|-----------------|-----------|-----------|-------|-----|-----|------|---------|
| | | | Min | Typ | Max | | |
| Clock frequency | f_{CRL} | - | 50 | 100 | 150 | kHz | |

12.4.4 Operating Conditions of Main PLL (in the Case of Using Main Clock for Input Clock of PLL)

(V_{CC} = 2.7V to 5.5V, V_{SS} = 0V)

| Parameter | Symbol | Value | | | Unit | Remarks |
|---|---------------------|-------|-----|-----|------------|---------|
| | | Min | Typ | Max | | |
| PLL oscillation stabilization wait time* ¹ (lock up time) | t _{LOCK} | 100 | - | - | µs | |
| PLL input clock frequency | f _{PLLI} | 4 | - | 16 | MHz | |
| PLL multiplication rate | - | 13 | - | 100 | multiplier | |
| PLL macro oscillation clock frequency | f _{PLLO} | 200 | - | 400 | MHz | |
| Main PLL clock frequency* ² | f _{CLKPLL} | - | - | 180 | MHz | |

- 1: Time from when the PLL starts operating until the oscillation stabilizes
- 2: For more information about Main PLL clock (CLKPLL), see Chapter 2-1: Clock in FM4 Family Peripheral Manual Main Part (MN709-00001).

12.4.5 Operating Conditions of USB/Ethernet PLL (in the Case of Using Main Clock for Input Clock of PLL)

(V_{CC} = 2.7V to 5.5V, V_{SS} = 0V)

| Parameter | Symbol | Value | | | Unit | Remarks |
|--|---------------------|-------|-----|-----|------------|-----------------------------------|
| | | Min | Typ | Max | | |
| PLL oscillation stabilization wait time ¹ (lock up time) | t _{LOCK} | 100 | - | - | µs | |
| PLL input clock frequency | f _{PLLI} | 4 | - | 16 | MHz | |
| PLL multiplication rate | - | 13 | - | 100 | multiplier | |
| PLL macro oscillation clock frequency | f _{PLLO} | 200 | - | 400 | MHz | USB/Ethernet |
| USB/Ethernet clock frequency ^{*2} | f _{CLKPLL} | - | - | 50 | MHz | After the M frequency division |

- 1: Time from when the PLL starts operating until the oscillation stabilizes
- 2: For more information about USB/Ethernet clock, see Chapter 2-2: USB/Ethernet Clock Generation in FM4 Family Peripheral Manual Communication Macro Part (MN709-00004).

12.4.6 Operating Conditions of Main PLL (in the Case of Using Built-in High-Speed CR Clock for Input Clock of Main PLL)
 (V_{CC} = 2.7V to 5.5V, V_{SS} = 0V)

| Parameter | Symbol | Value | | | Unit | Remarks |
|--|---------------------|-------|-----|-----|------------|---------|
| | | Min | Typ | Max | | |
| PLL oscillation stabilization wait time ¹ (lock up time) | t _{LOCK} | 100 | - | - | μs | |
| PLL input clock frequency | f _{PLLI} | 3.8 | 4 | 4.2 | MHz | |
| PLL multiplication rate | - | 50 | - | 95 | multiplier | |
| PLL macro oscillation clock frequency | f _{PLLO} | 190 | - | 400 | MHz | |
| Main PLL clock frequency ² | f _{CLKPLL} | - | - | 180 | MHz | |

1: Time from when the PLL starts operating until the oscillation stabilizes

2: For more information about Main PLL clock (CLKPLL), see Chapter 2-1: Clock in FM4 Family Peripheral Manual Main Part (MN709-00001).

Note:

- The High-speed CR clock (CLKHC) should be set with frequency/temperature trimming to act as the source clock of the Main PLL.

12.4.7 Reset Input Characteristics

 (V_{CC} = 2.7V to 5.5V, V_{SS} = 0V)

| Parameter | Symbol | Pin Name | Conditions | Value | | Unit | Remarks |
|------------------|--------------------|----------|------------|-------|-----|------|---------|
| | | | | Min | Typ | | |
| Reset input time | t _{INITX} | INITX | - | 500 | - | ns | |

12.4.8 Power-On Reset Timing

($V_{CC} = 2.7V$ to $5.5V$, $V_{SS} = 0V$)

| Parameter | Symbol | Pin Name | Value | | Unit | Remarks |
|-------------------------------------|------------|----------|-------|------|------|---------|
| | | | Min | Typ | | |
| Power supply rise time | t_{VCCR} | VCC | 0 | - | ms | |
| Power supply shut down time | t_{OFF} | | 1 | - | ms | |
| Time until releasing Power-on reset | t_{PRT} | | 0.33 | 0.60 | ms | |

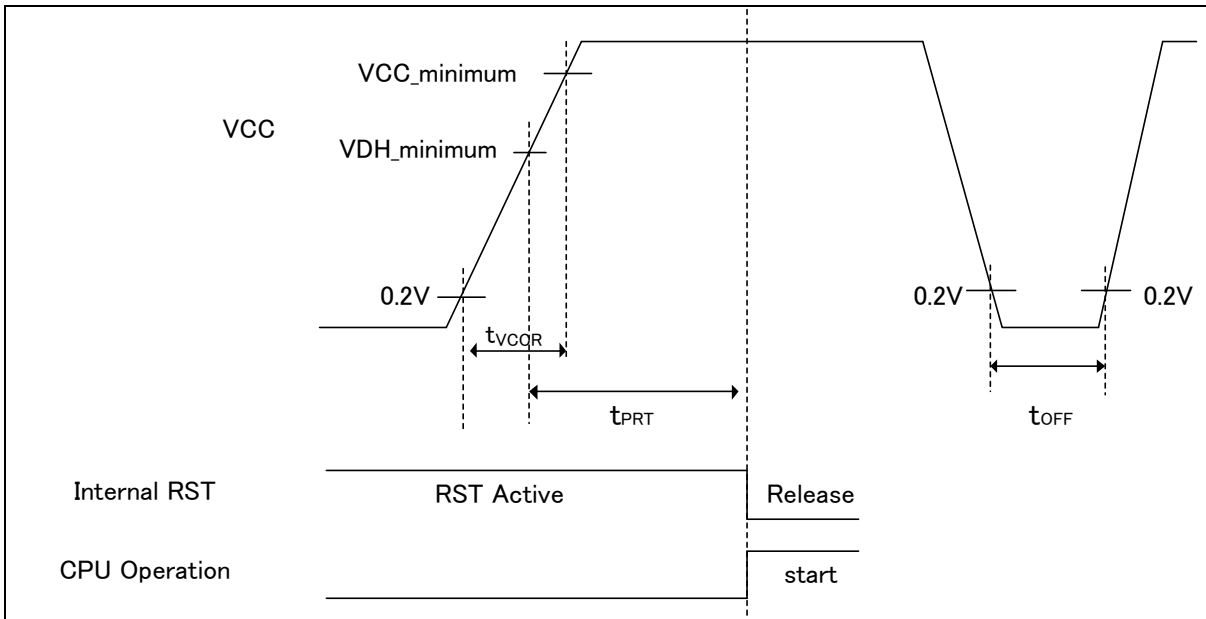

Glossary

- $V_{CC_minimum}$: minimum V_{CC} of recommended operating conditions
- $V_{DH_minimum}$: minimum release voltage of low-voltage detection reset
See 12.7. Low-Voltage Detection Characteristics.

12.4.9 GPIO Output Characteristics

($V_{CC} = 2.7V$ to $5.5V$, $V_{SS} = 0V$)

| Parameter | Symbol | Pin Name | Conditions | Value | | Unit | Remarks |
|------------------|--------------|----------|---------------------|-------|-----|------|---------|
| | | | | Min | Typ | | |
| Output frequency | t_{PCYCLE} | Pxx* | $V_{CC} \geq 4.5 V$ | - | 50 | MHz | |
| | | | $V_{CC} < 4.5 V$ | - | 32 | MHz | |

*: GPIO is a target.

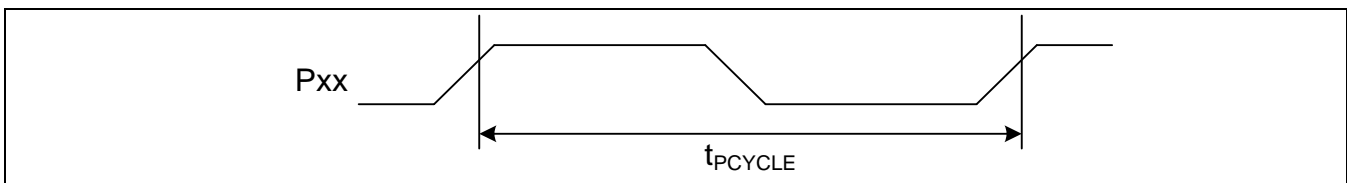

12.4.10 External Bus Timing

External Bus Clock Output Characteristics

| Parameter | Symbol | Pin Name | Conditions | Value | | Unit | Remarks |
|------------------|--------------------|-----------------------|------------|-------|------------------|------|---------|
| | | | | Min | Typ | | |
| Output frequency | t_{CYCLE} | MCLKOUT ^{*1} | | - | 50 ^{*2} | MHz | |

1: The external bus clock (MCLKOUT) is a divided clock of HCLK.

For more information about setting of clock divider, see Chapter 14: External Bus Interface in FM4 Family Peripheral Manual Main Part (MN709-00001).

2: Generate MCLKOUT at setting more than four divisions when the AHB bus clock exceeds 100 MHz.

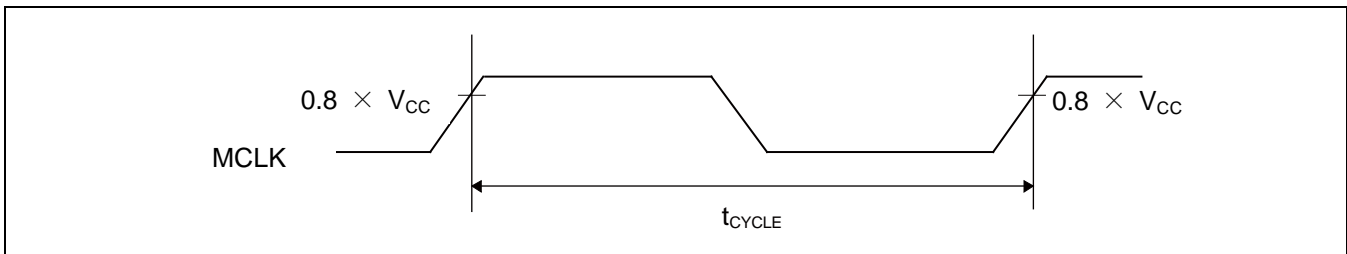

External Bus Signal I/O Characteristics

($V_{CC} = 2.7V$ to $5.5V$, $V_{SS} = 0V$)

| Parameter | Symbol | Conditions | Value | Unit | Remarks |
|-------------------------------|----------|------------|---------------------|------|---------|
| Signal input characteristics | V_{IH} | - | $0.8 \times V_{CC}$ | V | |
| | V_{IL} | | $0.2 \times V_{CC}$ | V | |
| Signal output characteristics | V_{OH} | | $0.8 \times V_{CC}$ | V | |
| | V_{OL} | | $0.2 \times V_{CC}$ | V | |

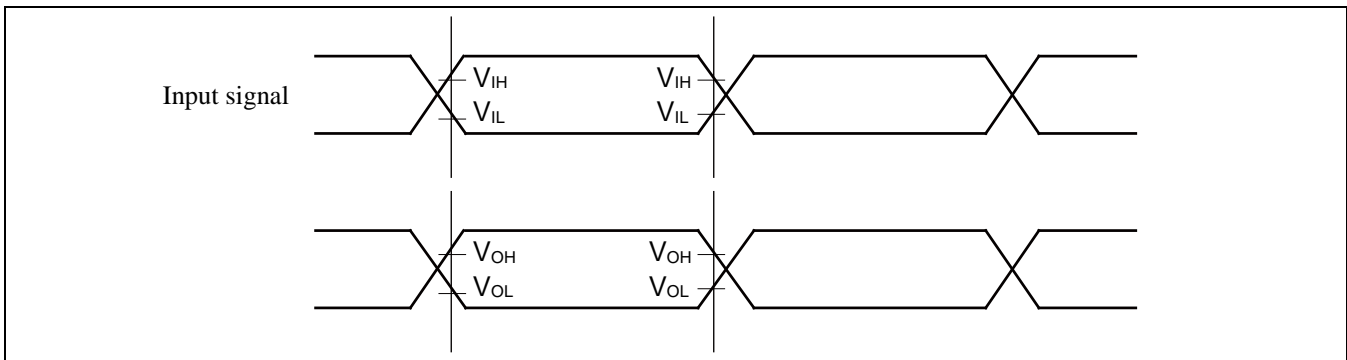

Separate Bus Access Asynchronous SRAM Mode

(V_{CC} = 2.7V to 5.5V, V_{SS} = 0V)

| Parameter | Symbol | Pin Name | Conditions | Value | | Unit | Remarks |
|---------------------------------------|--------------------------|---------------------------|------------|----------|----------|------|---------|
| | | | | Min | Max | | |
| MOEX Minimum pulse width | t _{OE} | MOEX | - | MCLKxn-3 | - | ns | |
| MCSX ↓ → Address output delay time | t _{CSL - AV} | MCSX[7: 0], MAD[24: 0] | - | -9 | +9 | ns | |
| MOEX ↑ → Address hold time | t _{OE} - AX | MOEX, MAD[24: 0] | - | 0 | MCLKxm+9 | ns | |
| MCSX ↓ → MOEX ↓ delay time | t _{CSL - OEL} | MOEX, MCSX[7: 0] | - | MCLKxm-9 | MCLKxm+9 | ns | |
| MOEX ↑ → MCSX ↑ time | t _{OE} - CSH | | - | 0 | MCLKxm+9 | ns | |
| MCSX ↓ → MDQM ↓ delay time | t _{CSL - RDQML} | MCSX, MDQM[3: 0] | - | MCLKxm-9 | MCLKxm+9 | ns | |
| Data set up → MOEX ↑ time | t _{DS - OE} | MOEX, MADATA[31: 0] | - | 20 | - | ns | |
| MOEX ↑ → Data hold time | t _{DH - OE} | MOEX, MADATA[31: 0] | - | 0 | - | ns | |
| MWEX Minimum pulse width | t _{WE} | MWEX | - | MCLKxn-3 | - | ns | |
| MWEX ↑ → Address output delay time | t _{WE} - AX | MWEX, MAD[24: 0] | - | 0 | MCLKxm+9 | ns | |
| MCSX ↓ → MWEX ↓ delay time | t _{CSL - WEL} | MWEX, MCSX[7: 0] | - | MCLKxn-9 | MCLKxn+9 | ns | |
| MWEX ↑ → MCSX ↑ delay time | t _{WE} - CSH | | - | 0 | MCLKxm+9 | ns | |
| MCSX ↓ → MDQM ↓ delay time | t _{CSL - WDQML} | MCSX, MDQM[3: 0] | - | MCLKxn-9 | MCLKxn+9 | ns | |
| MCSX ↓ → Data output time | t _{CSL - DX} | MCSX, MADATA[31: 0] | - | MCLK-9 | MCLK+9 | ns | |
| MWEX ↑ → Data hold time | t _{WE} - DX | MWEX, MADATA[31: 0] | - | 0 | MCLKxm+9 | ns | |

Note:

- When the external load capacitance C_L = 30 pF (m = 0 to 15, n = 1 to 16)

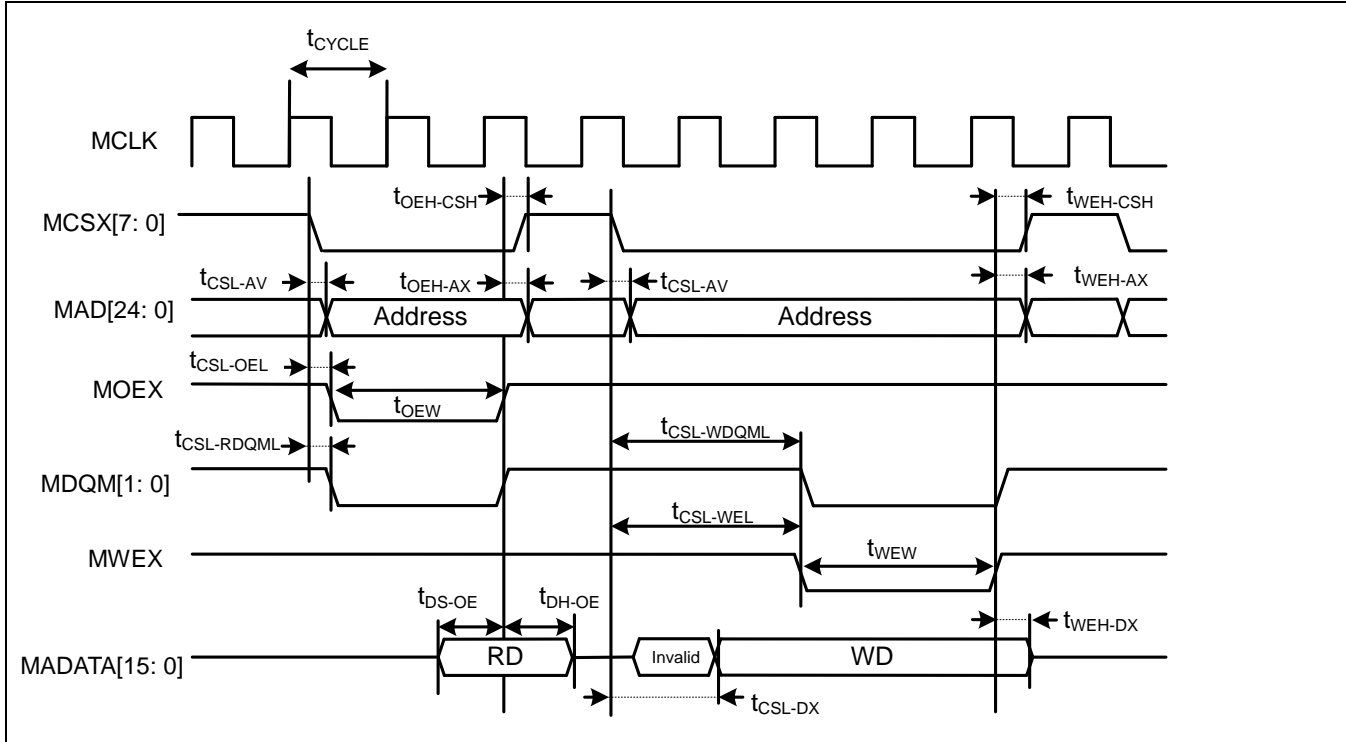

Separate Bus Access Synchronous SRAM Mode

($V_{CC} = 2.7V$ to $5.5V$, $V_{SS} = 0V$)

| Parameter | Symbol | Pin Name | Conditions | Value | | Unit | Remarks |
|------------------------------|------------|------------------------|------------|--------|---------|------|---------|
| | | | | Min | Max | | |
| Address delay time | t_{AV} | MCLK, MAD[24: 0] | - | 1 | 9 | ns | |
| MCSX delay time | t_{CSL} | MCLK, MCSX[7: 0] | - | 1 | 9 | ns | |
| | t_{CSH} | | - | 1 | 9 | ns | |
| MOEX delay time | t_{REL} | MCLK, MOEX | - | 1 | 9 | ns | |
| | t_{REH} | | - | 1 | 9 | ns | |
| Data set up →MCLK ↑ time | t_{DS} | MCLK, MADATA[31: 0] | - | 19 | - | ns | |
| MCLK ↑ → Data hold time | t_{DH} | MCLK, MADATA[31: 0] | - | 0 | - | ns | |
| MWEX delay time | t_{WEL} | MCLK, MWEX | - | 1 | 9 | ns | |
| | t_{WEH} | | - | 1 | 9 | ns | |
| MDQM[1: 0] delay time | t_{DQML} | MCLK, MDQM[3: 0] | - | 1 | 9 | ns | |
| | t_{DQMH} | | - | 1 | 9 | ns | |
| MCLK ↑ → Data output time | t_{ODS} | MCLK, MADATA[31: 0] | - | MCLK+1 | MCLK+18 | ns | |
| MCLK ↑ → Data hold time | t_{OD} | MCLK, MADATA[31: 0] | - | 1 | 18 | ns | |

Note:

- When the external load capacitance $CL = 30$ pF

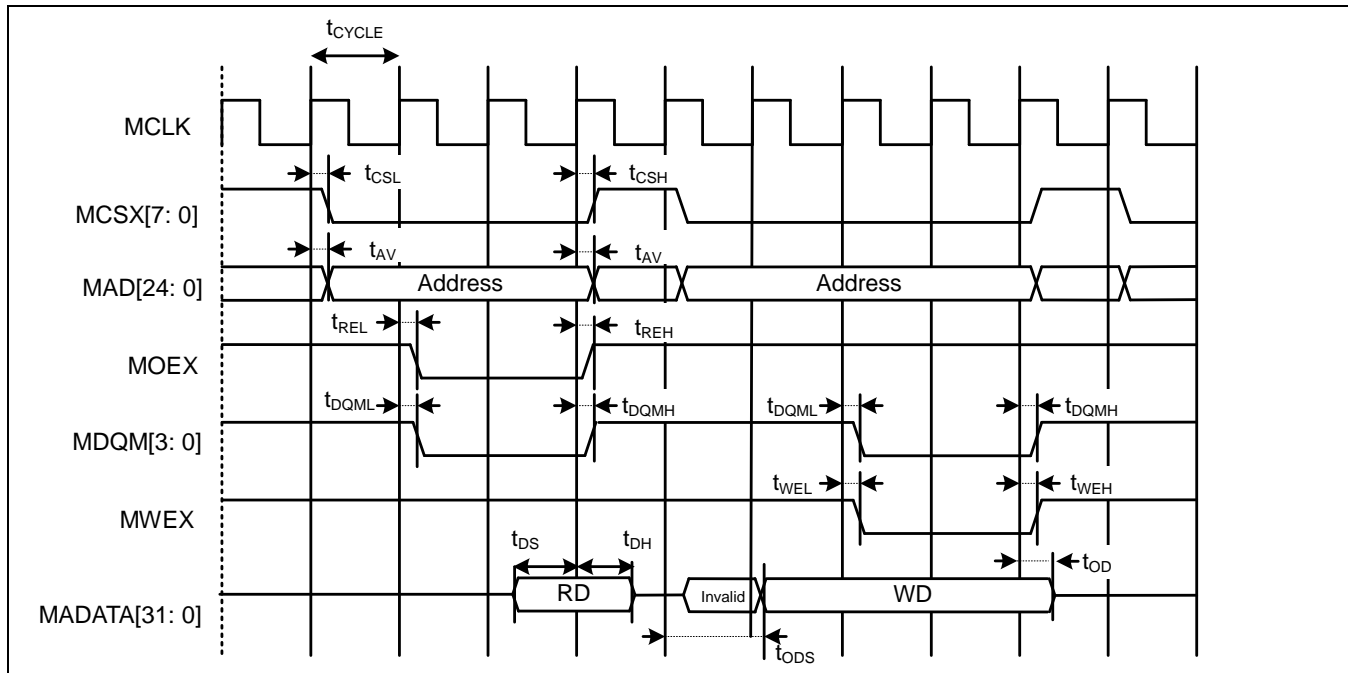

Multiplexed Bus Access Asynchronous SRAM Mode

($V_{CC} = 2.7V$ to $5.5V$, $V_{SS} = 0V$)

| Parameter | Symbol | Pin Name | Conditions | Value | | Unit | Remarks |
|--------------------------------|------------------|---------------------|------------|---------------------|----------------------|------|---------|
| | | | | Min | Max | | |
| Multiplexed address delay time | $t_{ALE-CHMADV}$ | MALE, MAD[24: 0] | - | 0 | 10 | ns | |
| Multiplexed address hold time | t_{CHMADH} | | - | $MCLK \times n + 0$ | $MCLK \times n + 10$ | ns | |

Note:

- When the external load capacitance $C_L = 30$ pF ($m = 0$ to 15 , $n = 1$ to 16)

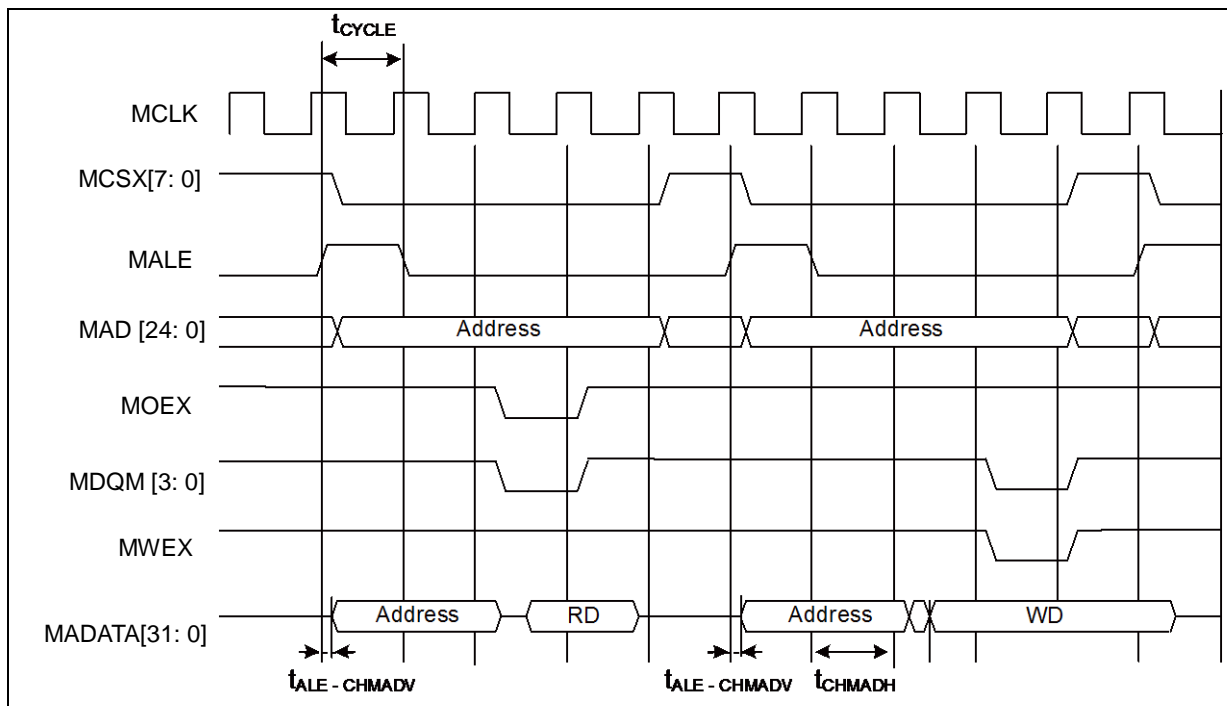

Multiplexed Bus Access Synchronous SRAM Mode

($V_{CC} = 2.7V$ to $5.5V$, $V_{SS} = 0V$)

| Parameter | Symbol | Pin Name | Conditions | Value | | Unit | Remarks |
|--|--------------|------------------------|------------|-------|----------|------|---------|
| | | | | Min | Max | | |
| MALE delay time | t_{CHAL} | MCLK, MALE | - | 1 | 9 | | |
| | t_{CHAH} | | - | 1 | 9 | | |
| MCLK \uparrow \rightarrow Multiplexed address delay time | t_{CHMADV} | MCLK, MADATA[31: 0] | - | 1 | t_{OD} | ns | |
| MCLK \uparrow \rightarrow Multiplexed data output time | t_{CHMADX} | | - | 1 | t_{OD} | ns | |

Note:

- When the external load capacitance $C_L = 30$ pF

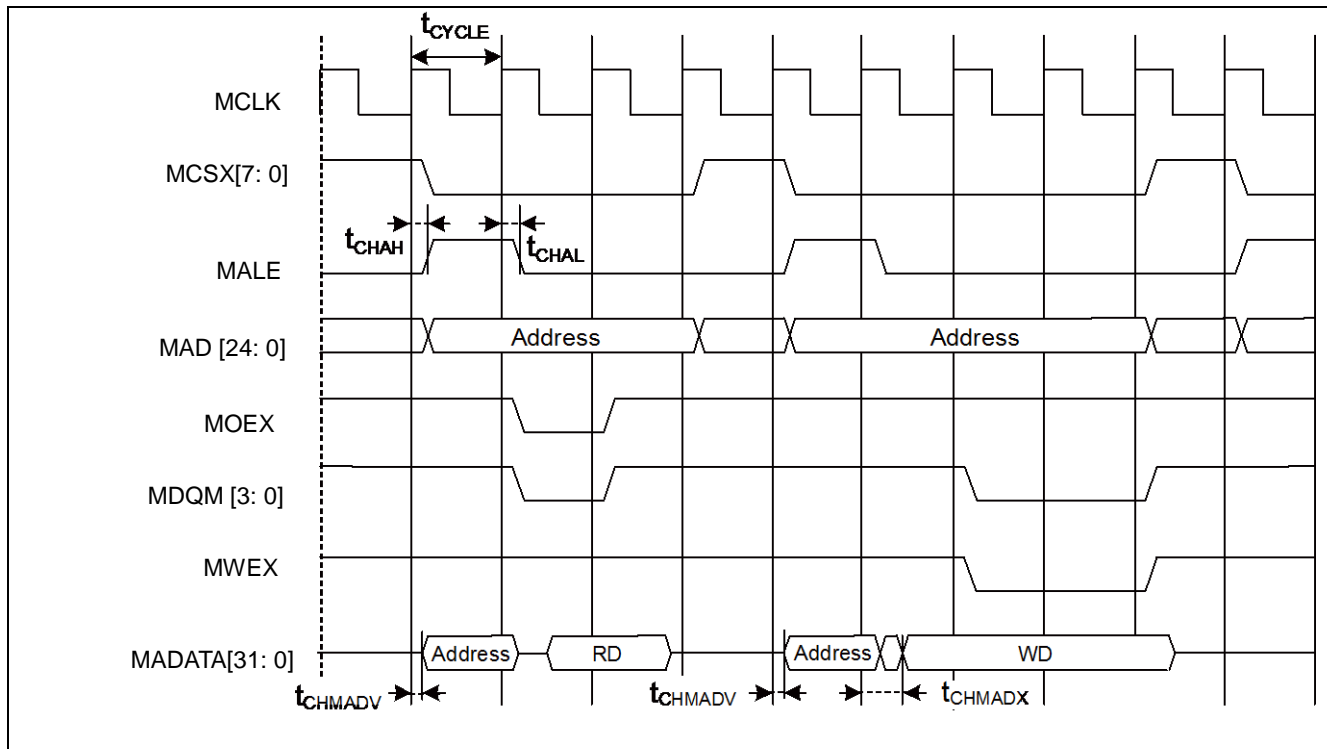

NAND Flash Mode

($V_{CC} = 2.7V$ to $5.5V$, $V_{SS} = 0V$)

| Parameter | Symbol | Pin Name | Conditions | Value | | Unit | Remarks |
|-------------------------------|-----------------|-------------------------|------------|---------------------|---------------------|------|---------|
| | | | | Min | Max | | |
| MNREX Min pulse width | t_{NREW} | MNREX | - | $MCLK \times n - 3$ | - | ns | |
| Data set up → MNREX ↑ time | t_{DS-NRE} | MNREX, MADATA[31: 0] | - | 20 | - | ns | |
| MNREX ↑ → Data hold time | t_{DH-NRE} | MNREX, MADATA[31: 0] | - | 0 | - | ns | |
| MNALE ↑ → MNWEX delay time | $t_{ALEH-NWEL}$ | MNALE, MNWEX | - | $MCLK \times m - 9$ | $MCLK \times m + 9$ | ns | |
| MNALE ↓ → MNWEX delay time | $t_{ALEL-NWEL}$ | MNALE, MNWEX | - | $MCLK \times m - 9$ | $MCLK \times m + 9$ | ns | |
| MNCLE ↑ → MNWEX delay time | $t_{CLEH-NWEL}$ | MNCLE, MNWEX | - | $MCLK \times m - 9$ | $MCLK \times m + 9$ | ns | |
| MNWEX ↑ → MNCLE delay time | $t_{NWEH-CLEL}$ | MNCLE, MNWEX | - | 0 | $MCLK \times m + 9$ | ns | |
| MNWEX Min pulse width | t_{NWEW} | MNWEX | - | $MCLK \times n - 3$ | - | ns | |
| MNWEX ↓ → Data output time | $t_{NWEV-DV}$ | MNWEX, MADATA[31: 0] | - | -9 | 9 | ns | |
| MNWEX ↑ → Data hold time | $t_{NWEH-DX}$ | MNWEX, MADATA[31: 0] | - | 0 | $MCLK \times m + 9$ | ns | |

Note:

- When the external load capacitance $C_L = 30$ pF ($m = 0$ to 15 , $n = 1$ to 16)

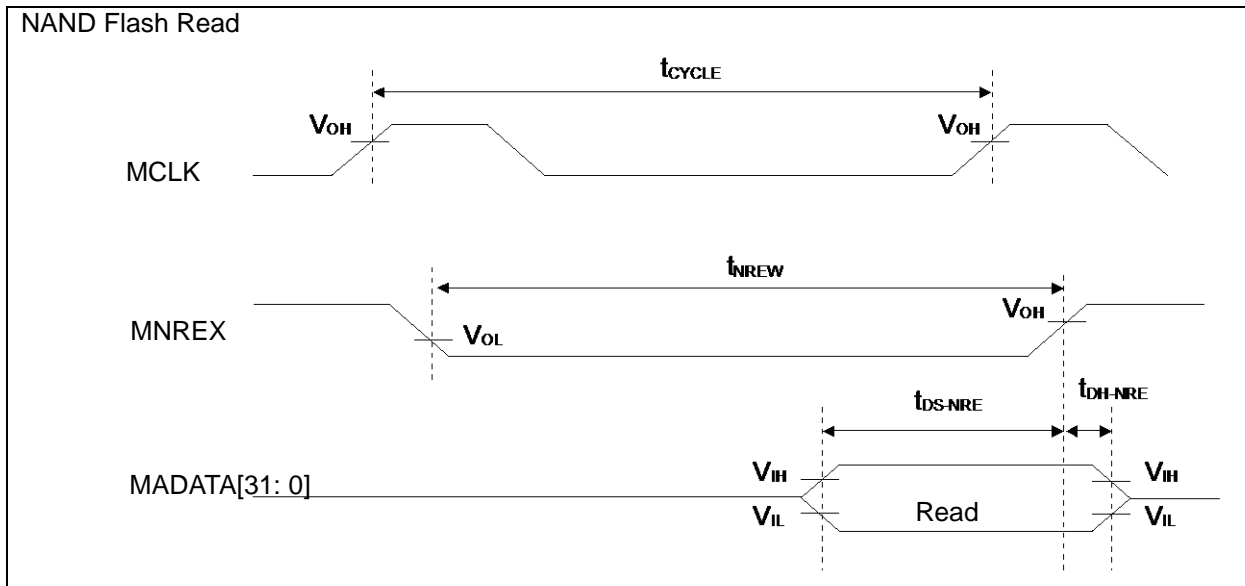

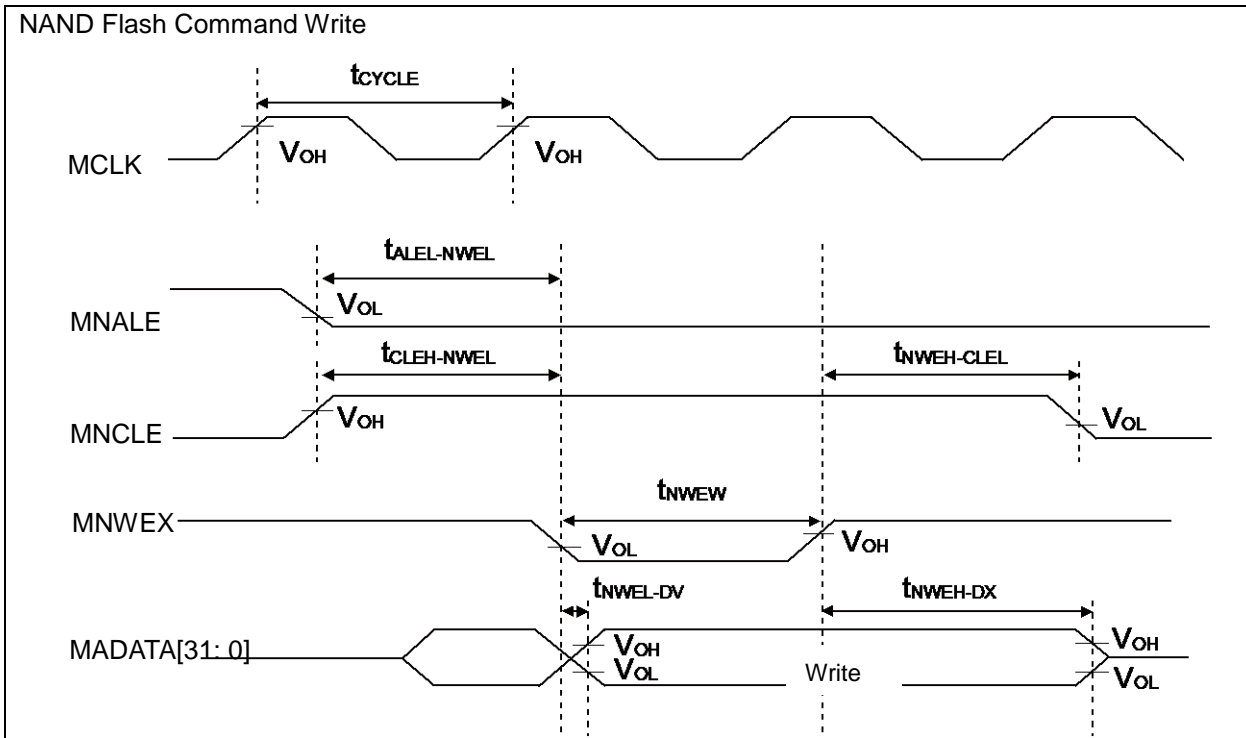
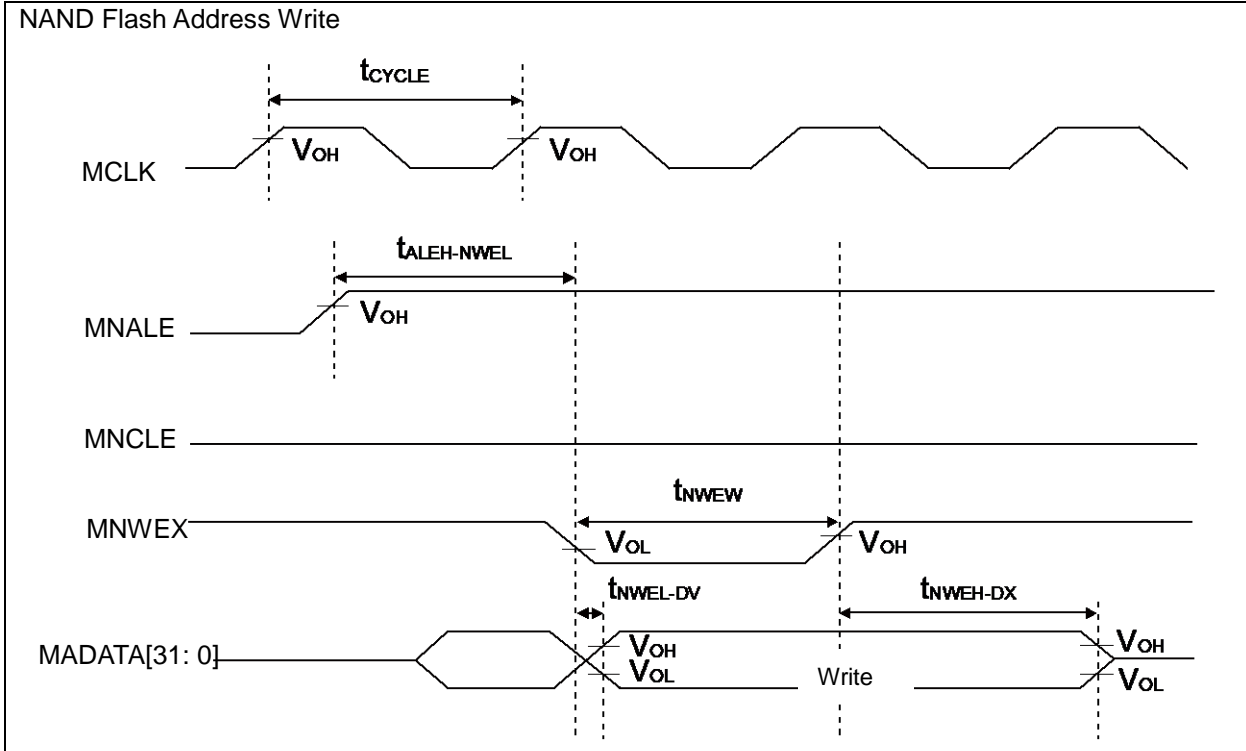

External Ready Input Timing

($V_{CC} = 2.7V$ to $5.5V$, $V_{SS} = 0V$)

| Parameter | Symbol | Pin Name | Conditions | Value | | Unit | Remarks |
|--------------------------------|------------|---------------|------------|-------|-----|------|---------|
| | | | | Min | Max | | |
| MCLK↑ MRDY input setup time | t_{RDYI} | MCLK, MRDY | - | 19 | - | ns | |

■ When RDY is input

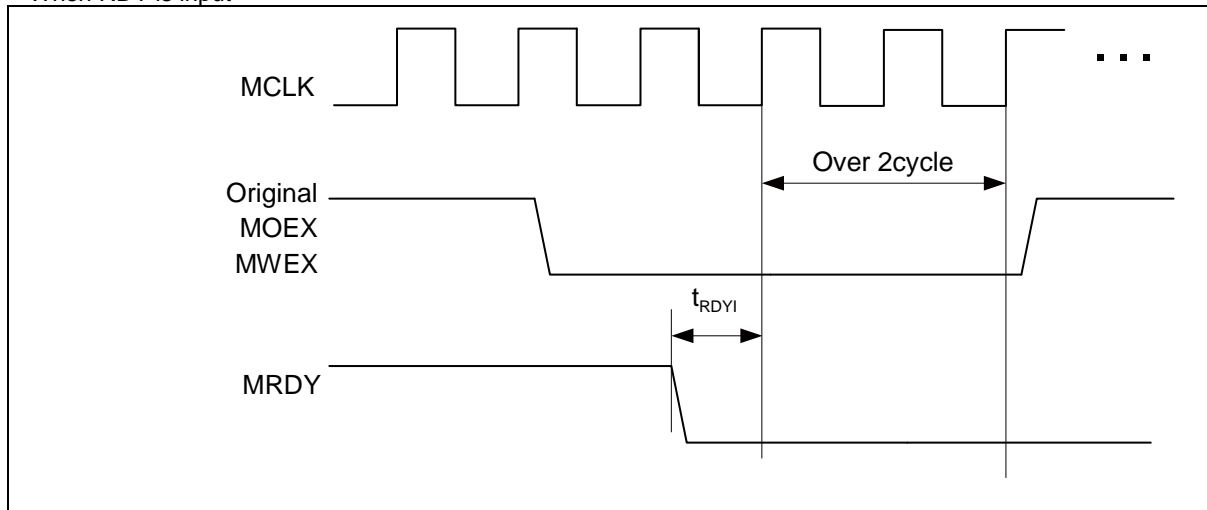

■ When RDY is released

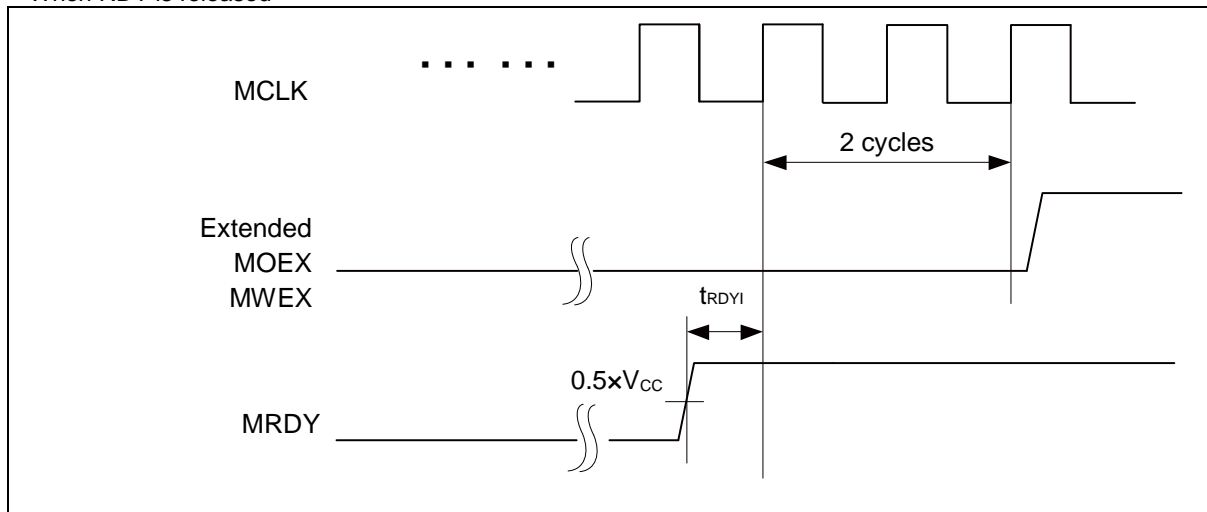

SDRAM Mode

(V_{CC} = 2.7V to 3.6V, V_{SS} = 0V)

| Parameter | Symbol | Pin Name | Value | Unit | | Unit | Remarks |
|--------------------------------------|--------------------|--------------------------|-------|------|------|------|---------|
| | | | | Min | Max | | |
| Output frequency | t _{CYCSD} | MSDCLK | - | - | 50 | MHz | |
| Address delay time | t _{AOSD} | MSDCLK, MAD[15: 0] | - | 2 | 12 | ns | |
| MSDCLK ↑ → Data output delay time | t _{DOSD} | MSDCLK, MADATA[31: 0] | - | 2 | 12 | ns | |
| MSDCLK ↑ → Data output Hi-Z time | t _{DOZSD} | MSDCLK, MADATA[31: 0] | - | 2 | 19.5 | ns | |
| MDQM[3: 0] delay time | t _{WROSD} | MSDCLK, MDQM[1: 0] | - | 1 | 12 | ns | |
| MCSX delay time | t _{MCSSD} | MSDCLK, MCSX8 | - | 2 | 12 | ns | |
| MRASX delay time | t _{RASSD} | MSDCLK, MRASX | - | 2 | 12 | ns | |
| MCASX delay time | t _{CASSD} | MSDCLK, MCASX | - | 2 | 12 | ns | |
| MSDWEX delay time | t _{MWESD} | MSDCLK, MSDWEX | - | 2 | 12 | ns | |
| MSDCKE delay time | t _{CKESD} | MSDCLK, MSDCKE | - | 2 | 12 | ns | |
| Data set up time | t _{DSSD} | MSDCLK, MADATA[31: 0] | - | 19 | - | ns | |
| Data hold time | t _{DHSD} | MSDCLK, MADATA[31: 0] | - | 0 | - | ns | |

Note:

- When the external load capacitance C_L = 30 pF

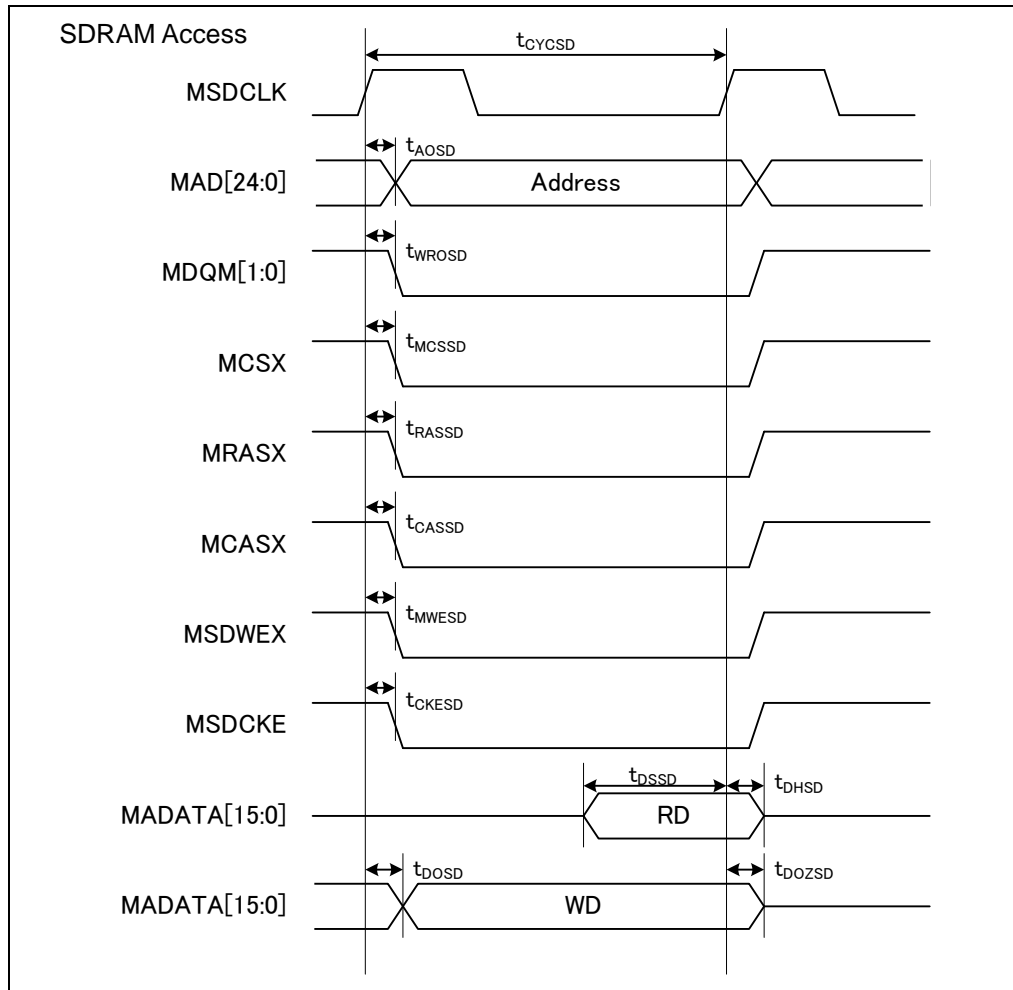

12.4.11 Base Timer Input Timing
Timer Input Timing

 ($V_{CC} = 2.7V$ to $5.5V$, $V_{SS} = 0V$)

| Parameter | Symbol | Pin Name | Conditions | Value | | Unit | Remarks |
|-------------------|-------------------------|---|------------|-------------|-----|------|---------|
| | | | | Min | Max | | |
| Input pulse width | t_{TIWH} , t_{TIWL} | TIOAn/TIOBn (when using as ECK, TIN) | - | $2t_{CYCP}$ | - | ns | |

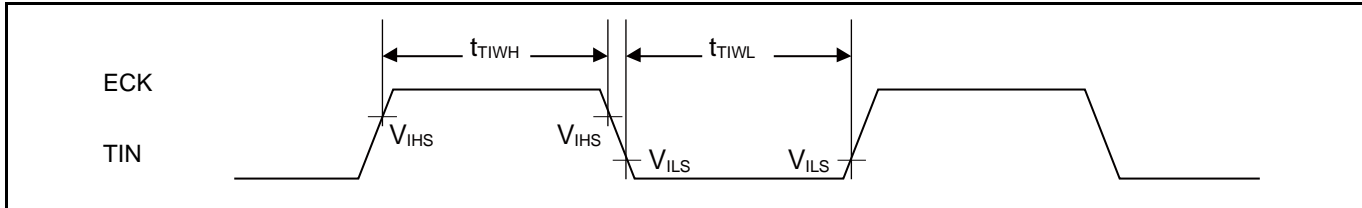
Trigger Input Timing

 ($V_{CC} = 2.7V$ to $5.5V$, $V_{SS} = 0V$)

| Parameter | Symbol | Pin Name | Conditions | Value | | Unit | Remarks |
|-------------------|-------------------------|-------------------------------------|------------|-------------|-----|------|---------|
| | | | | Min | Max | | |
| Input pulse width | t_{TRGH} , t_{TRGL} | TIOAn/TIOBn (when using as TGIN) | - | $2t_{CYCP}$ | - | ns | |

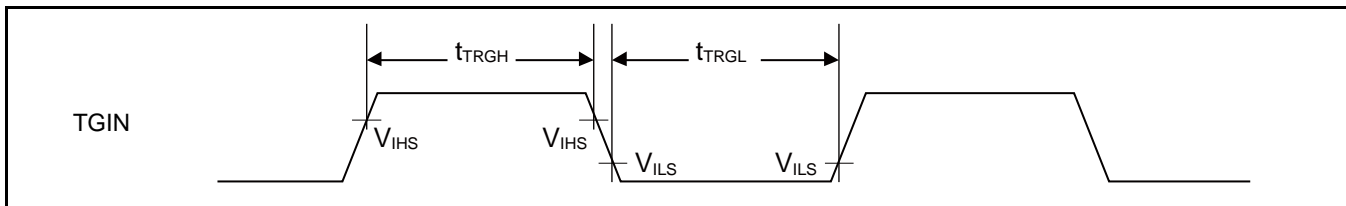
Note:

- t_{CYCP} indicates the APB bus clock cycle time. For more information about the APB bus number to which the base timer is connected, see 8. Block Diagram in this data sheet.

12.4.12 CSIO (SPI) Timing

Synchronous Serial (SPI = 0, SCINV = 0)

(V_{CC} = 2.7V to 5.5V, V_{SS} = 0V)

| Parameter | Symbol | Pin Name | Conditions | V _{CC} < 4.5 V | | V _{CC} ≥ 4.5 V | | Unit |
|----------------------------|--------------------|------------|--------------------------------|-------------------------|------------------------|-------------------------|------|------|
| | | | | Min | Max | Min | Max | |
| Baud rate | - | - | | - | 8 | - | 8 | Mbps |
| Serial clock cycle time | t _{SCYC} | SCKx | Internal shift clock operation | 4t _{CYCP} | - | 4t _{CYCP} | - | ns |
| SCK↓→SOT delay time | t _{SLOVI} | SCKx, SOTx | | - 30 | + 30 | - 20 | + 20 | ns |
| SIN→SCK↑ setup time | t _{IVSHI} | SCKx, SINx | | 50 | - | 30 | - | ns |
| SCK↑→SIN hold time | t _{SHIXI} | SCKx, SINx | | 0 | - | 0 | - | ns |
| Serial clock L pulse width | t _{SLSH} | SCKx | | 2t _{CYCP} - 10 | - | 2t _{CYCP} - 10 | - | ns |
| Serial clock H pulse width | t _{SHSL} | SCKx | t _{CYCP} + 10 | - | t _{CYCP} + 10 | - | ns | |
| SCK↓→SOT delay time | t _{SLOVE} | SCKx, SOTx | External shift clock operation | - | 50 | - | 30 | ns |
| SIN→SCK↑ setup time | t _{IVSHE} | SCKx, SINx | | 10 | - | 10 | - | ns |
| SCK↑→SIN hold time | t _{SHIXE} | SCKx, SINx | | 20 | - | 20 | - | ns |
| SCK fall time | t _F | SCKx | | - | 5 | - | 5 | ns |
| SCK rise time | t _R | SCKx | | - | 5 | - | 5 | ns |

Notes:

- The above characteristics apply to CLK synchronous mode.
- t_{CYCP} indicates the APB bus clock cycle time. For more information about the APB bus number to which the multi-function serial is connected, see 8. Block Diagram in this data sheet.
- These characteristics only guarantee the same relocate port number; for example, the combination of SCLKx_0 and SOTx_1 is not guaranteed.
- When the external load capacitance C_L = 30 pF.

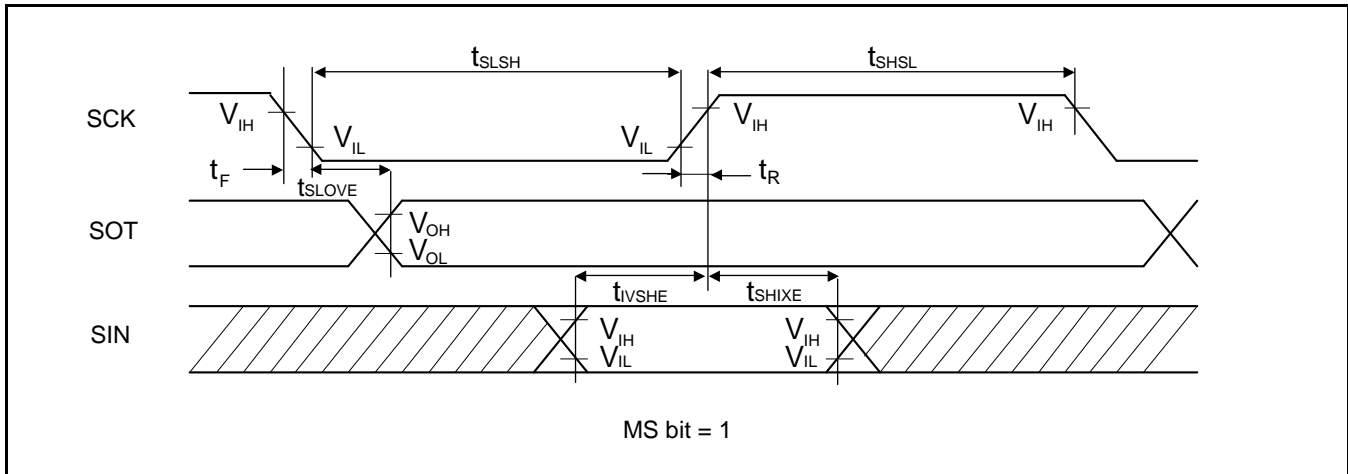
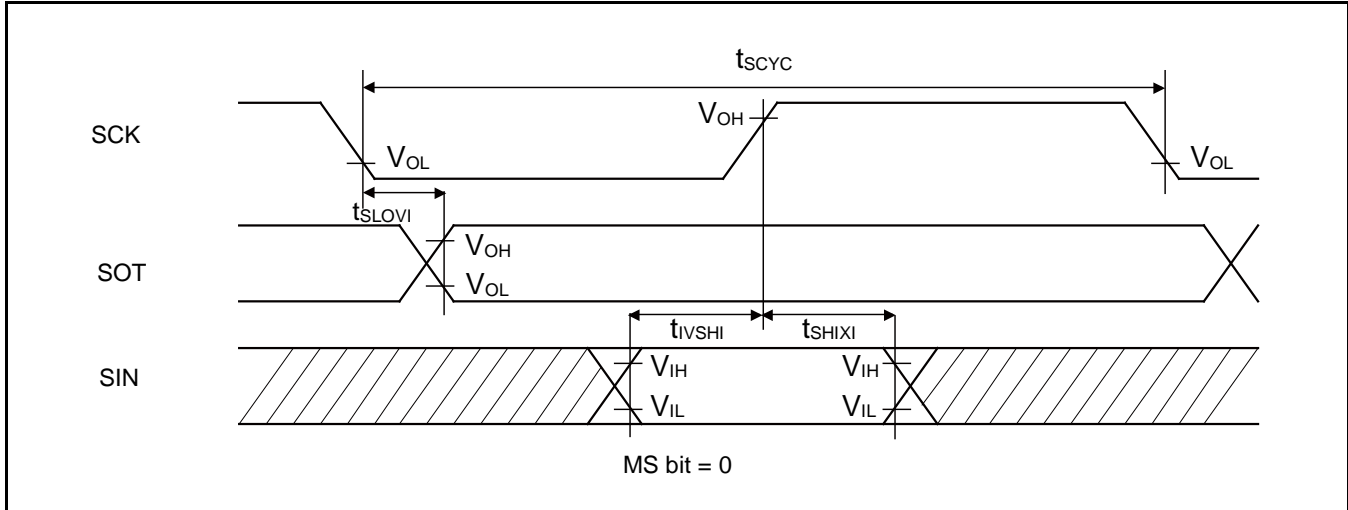

Synchronous Serial (SPI = 0, SCINV = 1)

 (V_{CC} = 2.7V to 5.5V, V_{SS} = 0V)

| Parameter | Symbol | Pin Name | Conditions | V _{CC} < 4.5 V | | V _{CC} ≥ 4.5 V | | Unit |
|----------------------------|--------------------|------------|--------------------------------|-------------------------|------------------------|-------------------------|------|------|
| | | | | Min | Max | Min | Max | |
| Baud rate | - | - | - | - | 8 | - | 8 | Mbps |
| Serial clock cycle time | t _{SCYC} | SCKx | Internal shift clock operation | 4t _{CYCP} | - | 4t _{CYCP} | - | ns |
| SCK↑→SOT delay time | t _{SHOVI} | SCKx, SOTx | | - 30 | + 30 | - 20 | + 20 | ns |
| SIN→SCK↓ setup time | t _{IVSLI} | SCKx, SINx | | 50 | - | 30 | - | ns |
| SCK↓→SIN hold time | t _{SLIXI} | SCKx, SINx | | 0 | - | 0 | - | ns |
| Serial clock L pulse width | t _{LSLH} | SCKx | | 2t _{CYCP} - 10 | - | 2t _{CYCP} - 10 | - | ns |
| Serial clock H pulse width | t _{SHSL} | SCKx | t _{CYCP} + 10 | - | t _{CYCP} + 10 | - | ns | |
| SCK↑→SOT delay time | t _{SHOVE} | SCKx, SOTx | External shift clock operation | - | 50 | - | 30 | ns |
| SIN→SCK↓ setup time | t _{IVSLE} | SCKx, SINx | | 10 | - | 10 | - | ns |
| SCK↓→SIN hold time | t _{SLIXE} | SCKx, SINx | | 20 | - | 20 | - | ns |
| SCK fall time | t _F | SCKx | | - | 5 | - | 5 | ns |
| SCK rise time | t _R | SCKx | | - | 5 | - | 5 | ns |

Notes:

- The above characteristics apply to CLK synchronous mode.
- t_{CYCP} indicates the APB bus clock cycle time. For more information about the APB bus number to which the multi-function serial is connected, see 8. Block Diagram in this data sheet.
- These characteristics only guarantee the same relocate port number; for example, the combination of SCLKx_0 and SOTx_1 is not guaranteed.
- When the external load capacitance C_L = 30 pF.

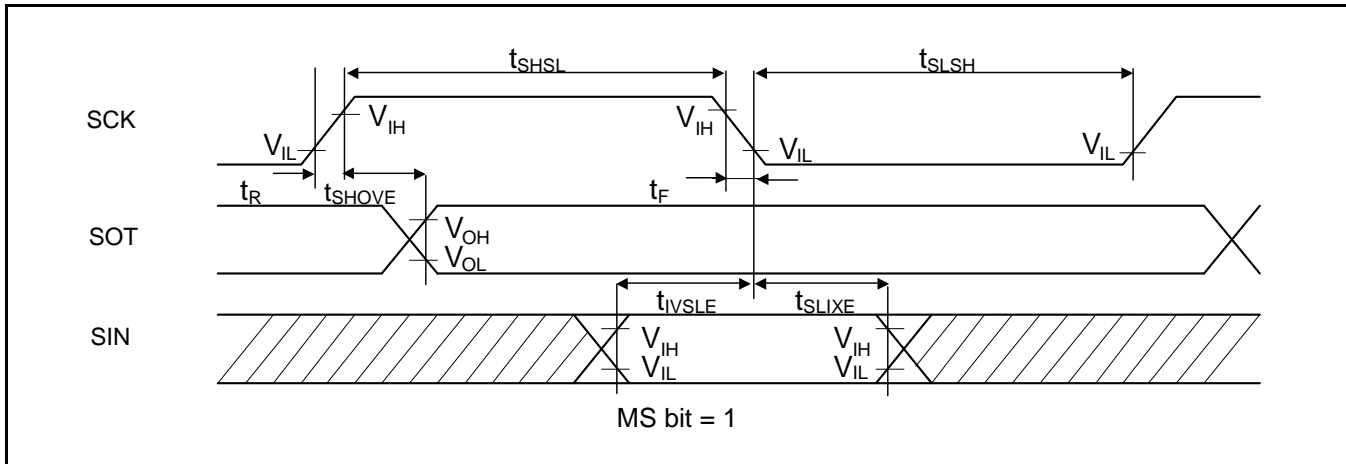
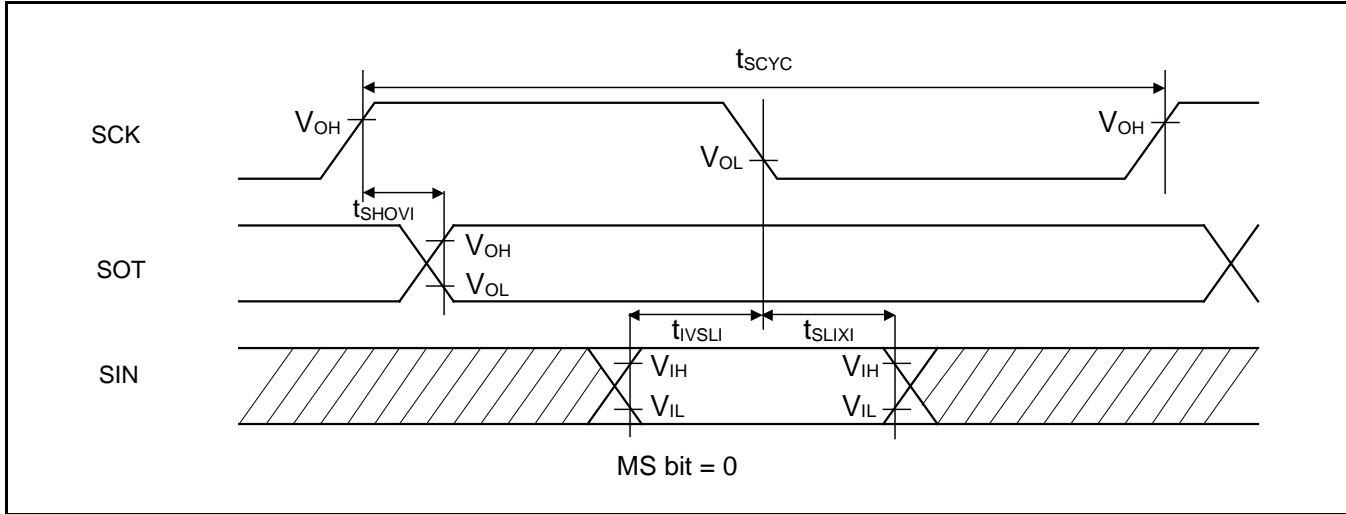

Synchronous Serial (SPI = 1, SCINV = 0)

(V_{CC} = 2.7V to 5.5V, V_{SS} = 0V)

| Parameter | Symbol | Pin Name | Conditions | V _{CC} < 4.5 V | | V _{CC} ≥ 4.5 V | | Unit |
|----------------------------|--------------------|------------|--------------------------------|-------------------------|------------------------|-------------------------|------|------|
| | | | | Min | Max | Min | Max | |
| Baud rate | - | - | - | - | 8 | - | 8 | Mbps |
| Serial clock cycle time | t _{SCYC} | SCKx | Internal shift clock operation | 4t _{CYCP} | - | 4t _{CYCP} | - | ns |
| SCK↑→SOT delay time | t _{SHOVI} | SCKx, SOTx | | - 30 | + 30 | - 20 | + 20 | ns |
| SIN→SCK↓ setup time | t _{IVSLI} | SCKx, SINx | | 50 | - | 30 | - | ns |
| SCK↓→SIN hold time | t _{SLIXI} | SCKx, SINx | | 0 | - | 0 | - | ns |
| SOT→SCK↓ delay time | t _{SOVLI} | SCKx, SOTx | | 2t _{CYCP} - 30 | - | 2t _{CYCP} - 30 | - | ns |
| Serial clock L pulse width | t _{SLSH} | SCKx | | 2t _{CYCP} - 10 | - | 2t _{CYCP} - 10 | - | ns |
| Serial clock H pulse width | t _{SHSL} | SCKx | t _{CYCP} + 10 | - | t _{CYCP} + 10 | - | ns | |
| SCK↑→SOT delay time | t _{SHOVE} | SCKx, SOTx | External shift clock operation | - | 50 | - | 30 | ns |
| SIN→SCK↓ setup time | t _{IVSLE} | SCKx, SINx | | 10 | - | 10 | - | ns |
| SCK↓→SIN hold time | t _{SLIXE} | SCKx, SINx | | 20 | - | 20 | - | ns |
| SCK fall time | t _F | SCKx | | - | 5 | - | 5 | ns |
| SCK rise time | t _R | SCKx | | - | 5 | - | 5 | ns |

Notes:

- The above characteristics apply to CLK synchronous mode.
- t_{CYCP} indicates the APB bus clock cycle time. For more information about the APB bus number to which the multi-function serial is connected, see 8. Block Diagram in this data sheet.
- These characteristics only guarantee the same relocate port number; for example, the combination of SCLKx_0 and SOTx_1 is not guaranteed.
- When the external load capacitance C_L = 30 pF.

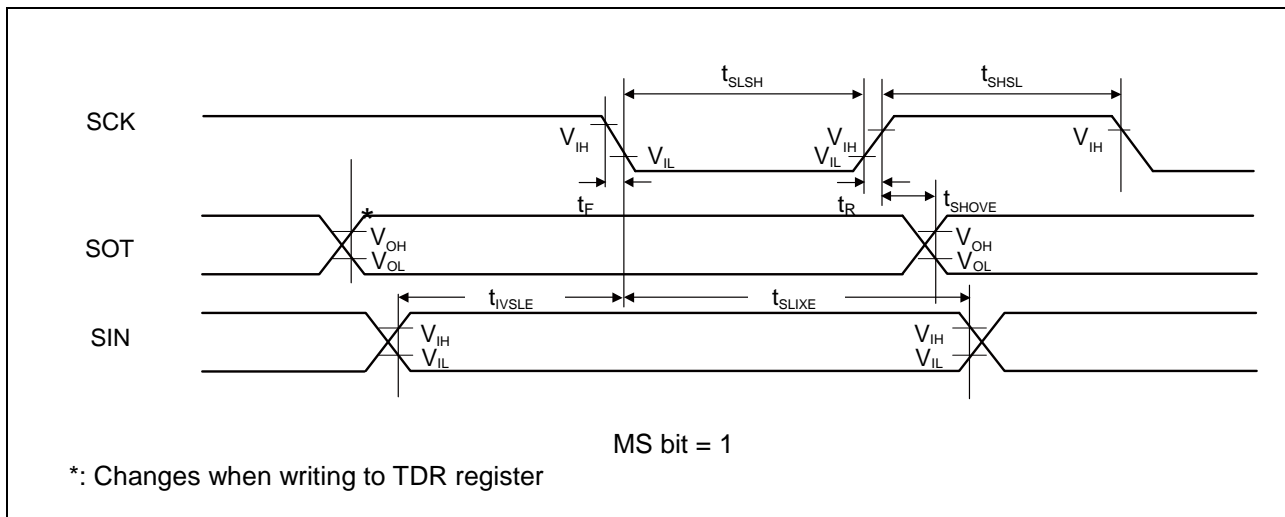
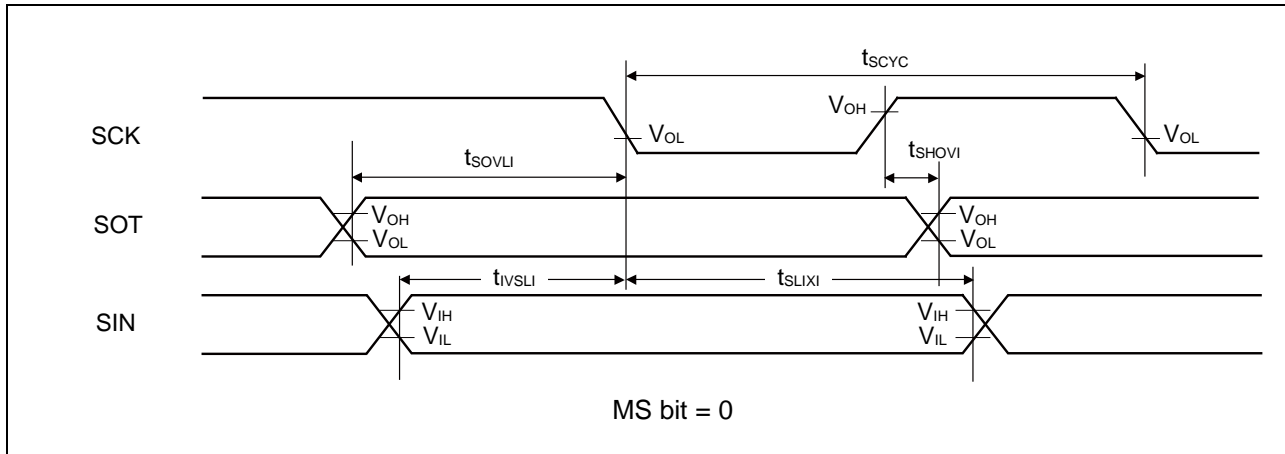

Synchronous Serial (SPI = 1, SCINV = 1)

 (V_{CC} = 2.7V to 5.5V, V_{SS} = 0V)

| Parameter | Symbol | Pin Name | Conditions | V _{CC} < 4.5 V | | V _{CC} ≥ 4.5 V | | Unit |
|----------------------------|--------------------|------------|--------------------------------|-------------------------|------------------------|-------------------------|------|------|
| | | | | Min | Max | Min | Max | |
| Baud rate | - | - | - | - | 8 | - | 8 | Mbps |
| Serial clock cycle time | t _{SCYC} | SCKx | Internal shift clock operation | 4t _{CYCP} | - | 4t _{CYCP} | - | ns |
| SCK↓→SOT delay time | t _{SLOVI} | SCKx, SOTx | | - 30 | + 30 | - 20 | + 20 | ns |
| SIN→SCK↑ setup time | t _{IVSHI} | SCKx, SINx | | 50 | - | 30 | - | ns |
| SCK↑→SIN hold time | t _{SHIXI} | SCKx, SINx | | 0 | - | 0 | - | ns |
| SOT→SCK↑ delay time | t _{SOVHI} | SCKx, SOTx | | 2t _{CYCP} - 30 | - | 2t _{CYCP} - 30 | - | ns |
| Serial clock L pulse width | t _{SLSH} | SCKx | | 2t _{CYCP} - 10 | - | 2t _{CYCP} - 10 | - | ns |
| Serial clock H pulse width | t _{SHSL} | SCKx | t _{CYCP} + 10 | - | t _{CYCP} + 10 | - | ns | |
| SCK↓→SOT delay time | t _{SLOVE} | SCKx, SOTx | External shift clock operation | - | 50 | - | 30 | ns |
| SIN→SCK↑ setup time | t _{IVSHE} | SCKx, SINx | | 10 | - | 10 | - | ns |
| SCK↑→SIN hold time | t _{SHIXE} | SCKx, SINx | | 20 | - | 20 | - | ns |
| SCK fall time | t _F | SCKx | | - | 5 | - | 5 | ns |
| SCK rise time | t _R | SCKx | | - | 5 | - | 5 | ns |

Notes:

- The above characteristics apply to CLK synchronous mode.
- t_{CYCP} indicates the APB bus clock cycle time. For more information about the APB bus number to which the multi-function serial is connected, see 8. Block Diagram in this data sheet.
- These characteristics only guarantee the same relocate port number; for example, the combination of SCLKx_0 and SOTx_1 is not guaranteed.
- When the external load capacitance C_L = 30 pF.

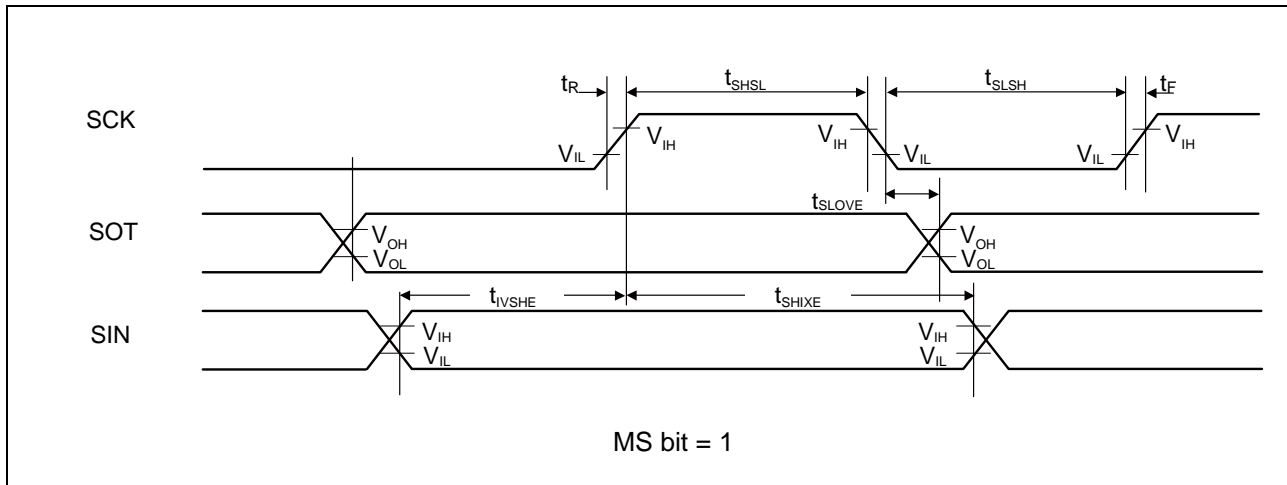
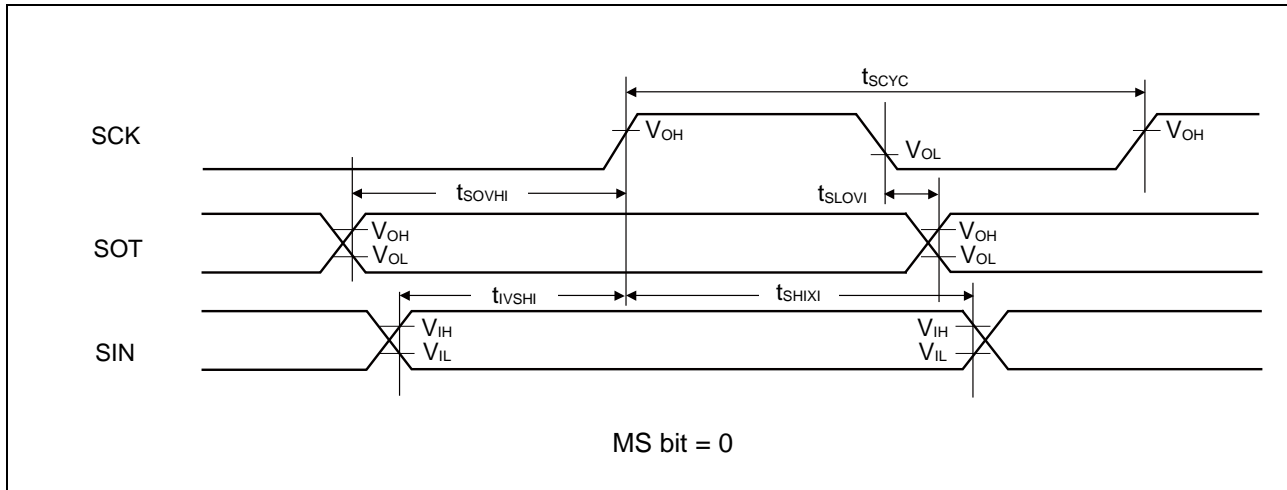

When Using Synchronous Serial Chip Select (SPI = 1, SCINV = 0, MS = 0, CSLVL = 1)

 (V_{CC} = 2.7V to 5.5V, V_{SS} = 0V)

| Parameter | Symbol | Conditions | V _{CC} < 4.5 V | | V _{CC} ≥ 4.5 V | | Unit |
|-----------------------|-------------------|--------------------------------|--------------------------------|--------------------------------|--------------------------------|--------------------------------|------|
| | | | Min | Max | Min | Max | |
| SCS↓→SCK↓ setup time | t _{CSSI} | Internal shift clock operation | (*1)-50 | (*1)+0 | (*1)-50 | (*1)+0 | ns |
| SCK↑→SCS↑ hold time | t _{CShI} | | (*2)+0 | (*2)+50 | (*2)+0 | (*2)+50 | ns |
| SCS deselect time | t _{CSDI} | | (*3)-50 +5t _{CYCP} | (*3)+50 +5t _{CYCP} | (*3)-50 +5t _{CYCP} | (*3)+50 +5t _{CYCP} | ns |
| SCS↓→SCK↓ setup time | t _{CSE} | External shift clock operation | 3t _{CYCP} +30 | - | 3t _{CYCP} +30 | - | ns |
| SCK↑→SCS↑ hold time | t _{CSE} | | 0 | - | 0 | - | ns |
| SCS deselect time | t _{CSE} | | 3t _{CYCP} +30 | - | 3t _{CYCP} +30 | - | ns |
| SCS ↓ →SOT delay time | t _{DSE} | | - | 40 | - | 40 | ns |
| SCS ↑ →SOT delay time | t _{DEE} | | 0 | - | 0 | - | ns |

(*1): CSSU bit value × serial chip select timing operating clock cycle [ns]

(*2): CSHD bit value × serial chip select timing operating clock cycle [ns]

(*3): CSDS bit value × serial chip select timing operating clock cycle [ns]

Notes:

- t_{CYCP} indicates the APB bus clock cycle time. For more information about the APB bus number to which the multi-function serial is connected, see 8. Block Diagram in this data sheet.
- For more information about CSSU, CSHD, CSDS, and the serial chip select timing operating clock, see FM4 Family Peripheral Manual Main Part (MN709-00001).
- When the external load capacitance C_L = 30 pF.

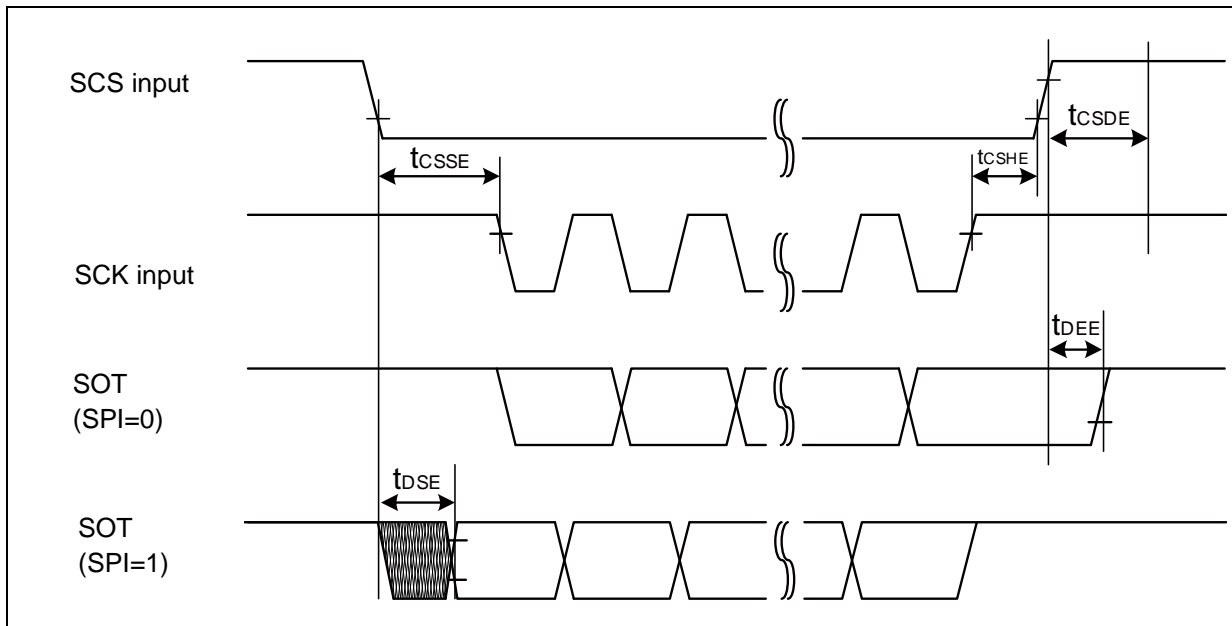
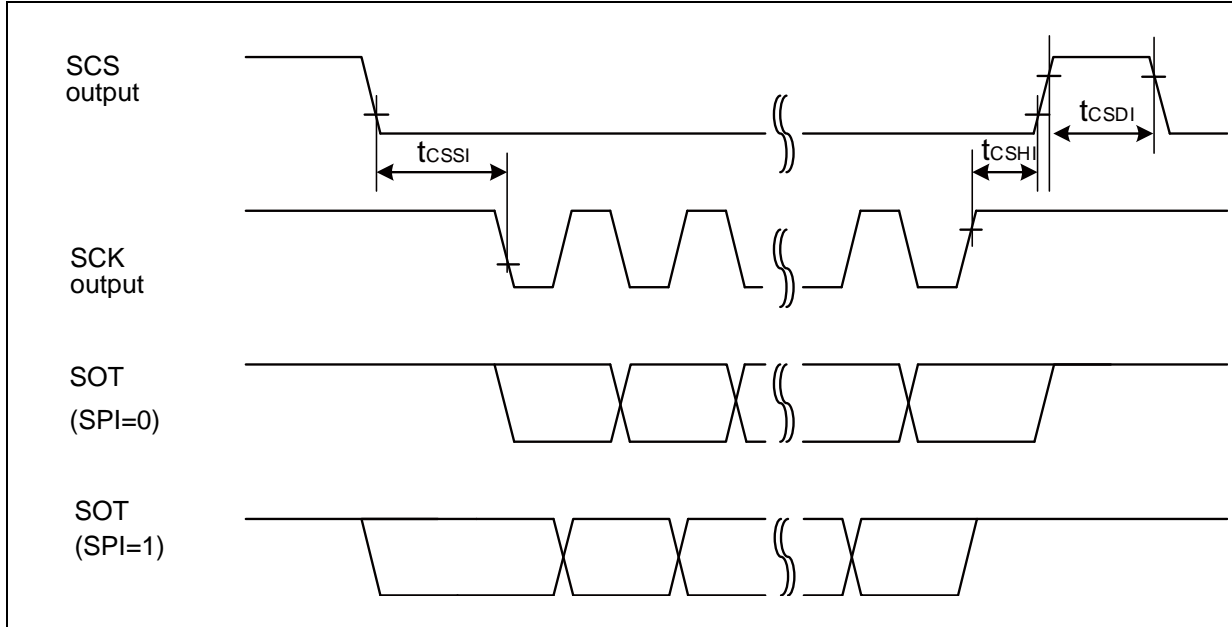

When Using Synchronous Serial Chip Select (SPI = 1, SCINV = 1, MS = 0, CSLVL = 1)

 (V_{CC} = 2.7V to 5.5V, V_{SS} = 0V)

| Parameter | Symbol | Conditions | V _{CC} < 4.5 V | | V _{CC} ≥ 4.5 V | | Unit |
|-----------------------|-------------------|--------------------------------|--------------------------------|--------------------------------|--------------------------------|--------------------------------|------|
| | | | Min | Max | Min | Max | |
| SCS↓→SCK↓ setup time | t _{CSSI} | Internal shift clock operation | (*1)-50 | (*1)+0 | (*1)-50 | (*1)+0 | ns |
| SCK↑→SCS↑ hold time | t _{CShI} | | (*2)+0 | (*2)+50 | (*2)+0 | (*2)+50 | ns |
| SCS deselect time | t _{CSDI} | | (*3)-50 +5t _{CYCP} | (*3)+50 +5t _{CYCP} | (*3)-50 +5t _{CYCP} | (*3)+50 +5t _{CYCP} | ns |
| SCS↓→SCK↓ setup time | t _{CSSE} | External shift clock operation | 3t _{CYCP} +30 | - | 3t _{CYCP} +30 | - | ns |
| SCK↑→SCS↑ hold time | t _{CSHE} | | 0 | - | 0 | - | ns |
| SCS deselect time | t _{CSDE} | | 3t _{CYCP} +30 | - | 3t _{CYCP} +30 | - | ns |
| SCS ↓ →SOT delay time | t _{DSE} | | - | 40 | - | 40 | ns |
| SCS ↑ →SOT delay time | t _{DEE} | | 0 | - | 0 | - | ns |

(*1): CSSU bit value × serial chip select timing operating clock cycle [ns]

(*2): CSHD bit value × serial chip select timing operating clock cycle [ns]

(*3): CSDS bit value × serial chip select timing operating clock cycle [ns]

Notes:

- t_{CYCP} indicates the APB bus clock cycle time. For more information about the APB bus number to which the multi-function serial is connected, see 8. Block Diagram in this data sheet.
- For more information about CSSU, CSHD, CSDS, and the serial chip select timing operating clock, see FM4 Family Peripheral Manual Main Part (MN709-00001).
- When the external load capacitance C_L = 30 pF.

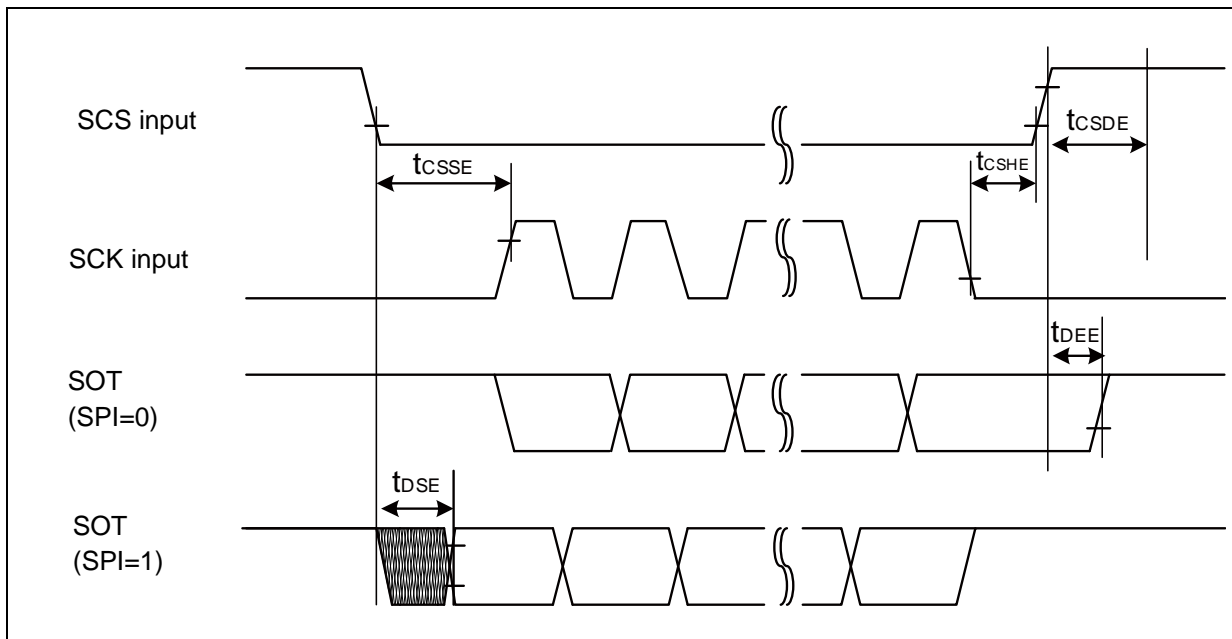
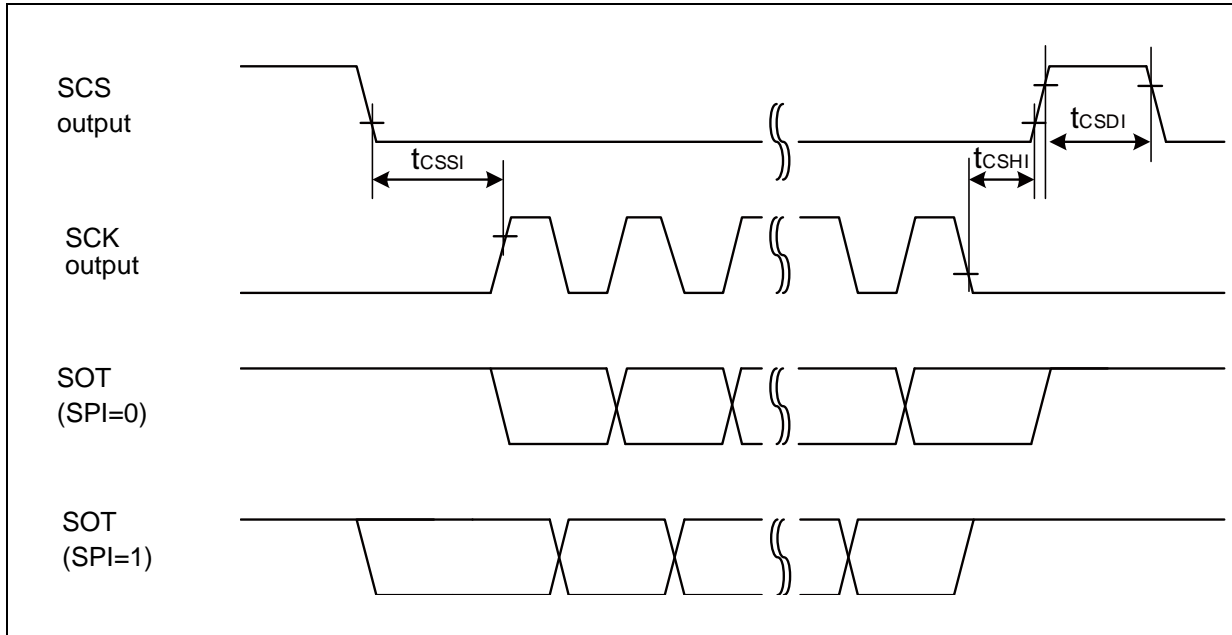

When Using Synchronous Serial Chip Select (SPI = 1, SCINV = 0, MS = 0, CSLVL = 0)

 (V_{CC} = 2.7V to 5.5V, V_{SS} = 0V)

| Parameter | Symbol | Conditions | V _{CC} < 4.5 V | | V _{CC} ≥ 4.5 V | | Unit |
|----------------------|--------------------|--------------------------------|--------------------------------|--------------------------------|--------------------------------|--------------------------------|------|
| | | | Min | Max | Min | Max | |
| SCS↑→SCK↓ setup time | t _{CSSI} | Internal shift clock operation | (*1)-50 | (*1)+0 | (*1)-50 | (*1)+0 | ns |
| SCK↑→SCS↓ hold time | t _{CSDI} | | (*2)+0 | (*2)+50 | (*2)+0 | (*2)+50 | ns |
| SCS deselect time | t _{CSDI} | | (*3)-50 +5t _{CYCP} | (*3)+50 +5t _{CYCP} | (*3)-50 +5t _{CYCP} | (*3)+50 +5t _{CYCP} | ns |
| SCS↑→SCK↓ setup time | t _{CSSSE} | External shift clock operation | 3t _{CYCP} +30 | - | 3t _{CYCP} +30 | - | ns |
| SCK↑→SCS↓ hold time | t _{CSE} | | 0 | - | 0 | - | ns |
| SCS deselect time | t _{CSE} | | 3t _{CYCP} +30 | - | 3t _{CYCP} +30 | - | ns |
| SCS↑→SOT delay time | t _{DSE} | | - | 40 | - | 40 | ns |
| SCS↓→SOT delay time | t _{DEE} | | 0 | - | 0 | - | ns |

(*1): CSSU bit value × serial chip select timing operating clock cycle [ns]

(*2): CSHD bit value × serial chip select timing operating clock cycle [ns]

(*3): CSDS bit value × serial chip select timing operating clock cycle [ns]

Notes:

- t_{CYCP} indicates the APB bus clock cycle time. For more information about the APB bus number to which the multi-function serial is connected, see 8. Block Diagram in this data sheet.
- For more information about CSSU, CSHD, CSDS, and the serial chip select timing operating clock, see FM4 Family Peripheral Manual Main Part (MN709-00001).
- When the external load capacitance C_L = 30 pF.

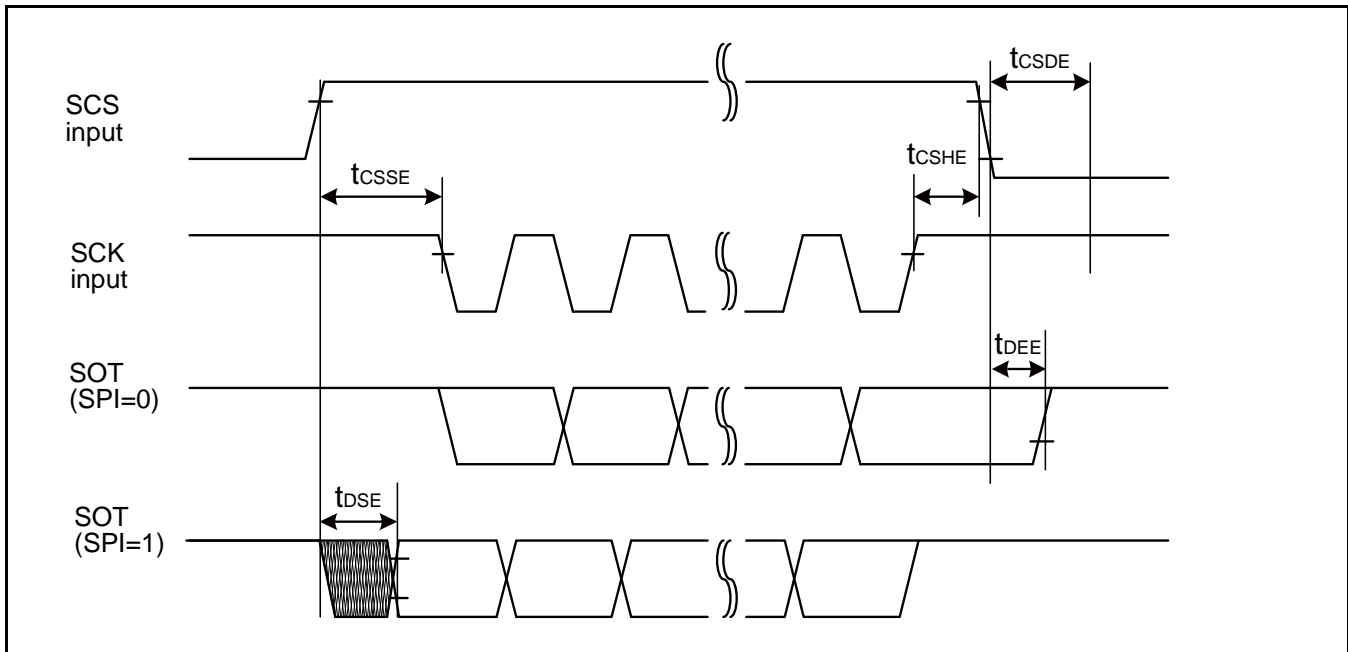
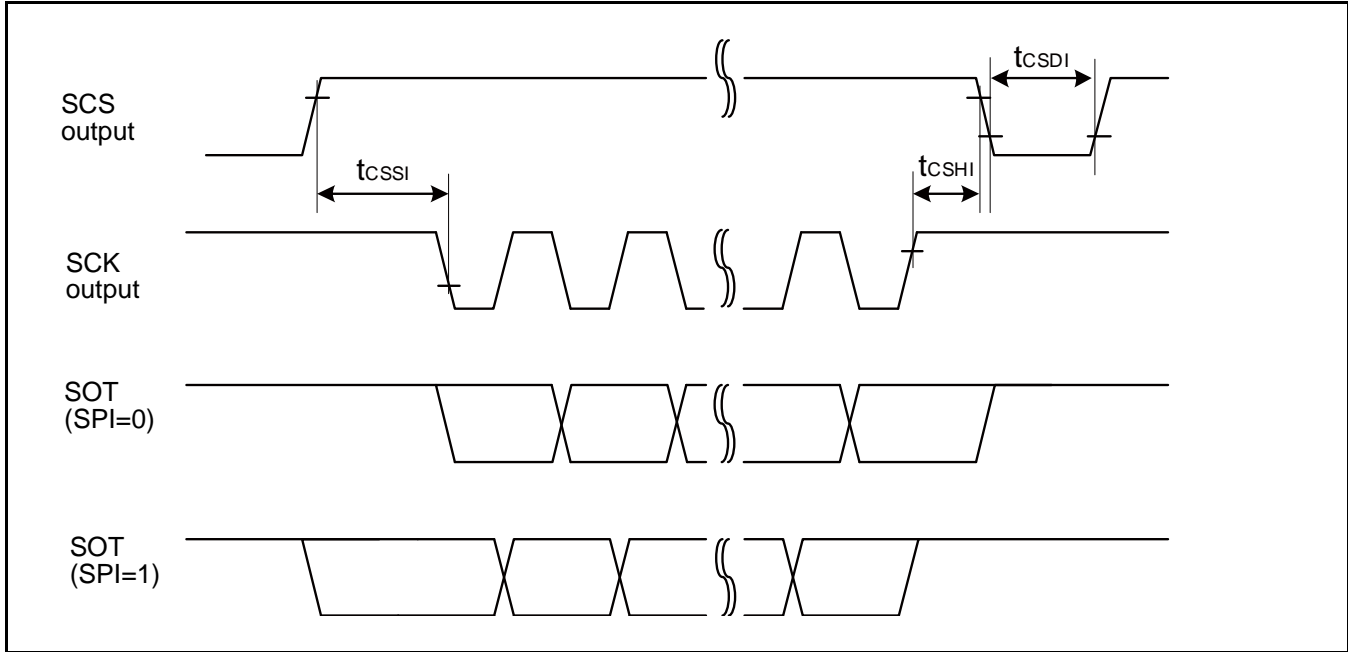

When Using Synchronous Serial Chip Select (SPI = 1, SCINV = 1, MS = 0, CSLVL = 0)

(V_{CC} = 2.7V to 5.5V, V_{SS} = 0V)

| Parameter | Symbol | Conditions | V _{CC} < 4.5 V | | V _{CC} ≥ 4.5 V | | Units |
|--------------------------|-------------------|--------------------------------|--------------------------------|--------------------------------|--------------------------------|--------------------------------|-------|
| | | | Min | Max | Min | Max | |
| SCS ↑ → SCK ↑ setup time | t _{CSSI} | Internal shift clock operation | (*1)-50 | (*1)+0 | (*1)-50 | (*1)+0 | ns |
| SCK ↓ → SCS ↓ hold time | t _{CShI} | | (*2)+0 | (*2)+50 | (*2)+0 | (*2)+50 | ns |
| SCS deselect time | t _{CSDI} | | (*3)-50 +5t _{CYCP} | (*3)+50 +5t _{CYCP} | (*3)-50 +5t _{CYCP} | (*3)+50 +5t _{CYCP} | ns |
| SCS ↑ → SCK ↑ setup time | t _{CSSE} | External shift clock operation | 3t _{CYCP} +30 | - | 3t _{CYCP} +30 | - | ns |
| SCK ↓ → SCS ↓ hold time | t _{CSHE} | | 0 | - | 0 | - | ns |
| SCS deselect time | t _{CSDE} | | 3t _{CYCP} +30 | - | 3t _{CYCP} +30 | - | ns |
| SCS ↑ → SOT delay time | t _{DSE} | | - | 40 | - | 40 | ns |
| SCS ↓ → SOT delay time | t _{DEE} | | 0 | - | 0 | - | ns |

(*1): CSSU bit value × serial chip select timing operating clock cycle [ns]

(*2): CSHD bit value × serial chip select timing operating clock cycle [ns]

(*3): CSDS bit value × serial chip select timing operating clock cycle [ns]

Notes:

- t_{CYCP} indicates the APB bus clock cycle time. For more information about the APB bus number to which the multi-function serial is connected, see 8. Block Diagram in this data sheet.
- For more information about CSSU, CSHD, CSDS, and the serial chip select timing operating clock, see FM4 Family Peripheral Manual Main Part (MN709-00001).
- When the external load capacitance C_L = 30 pF.

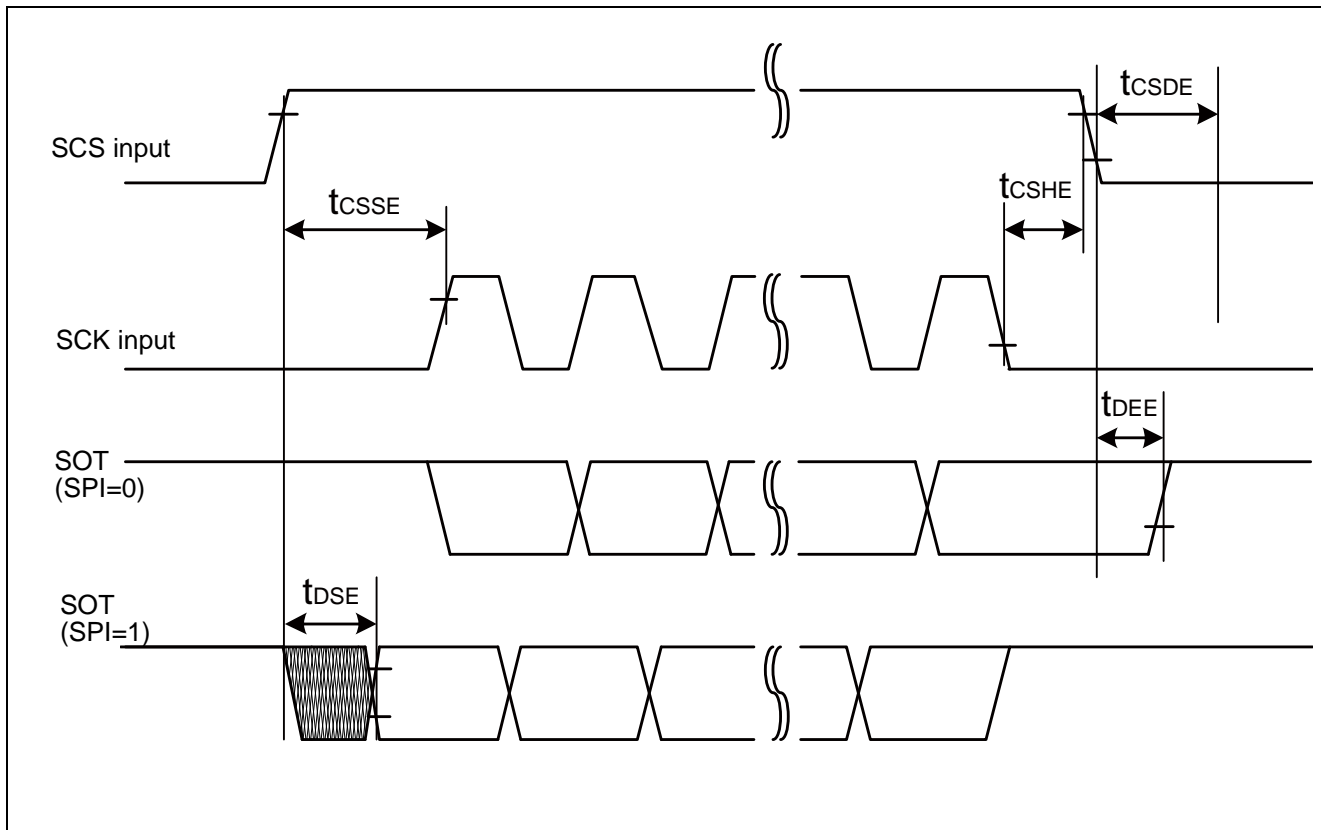
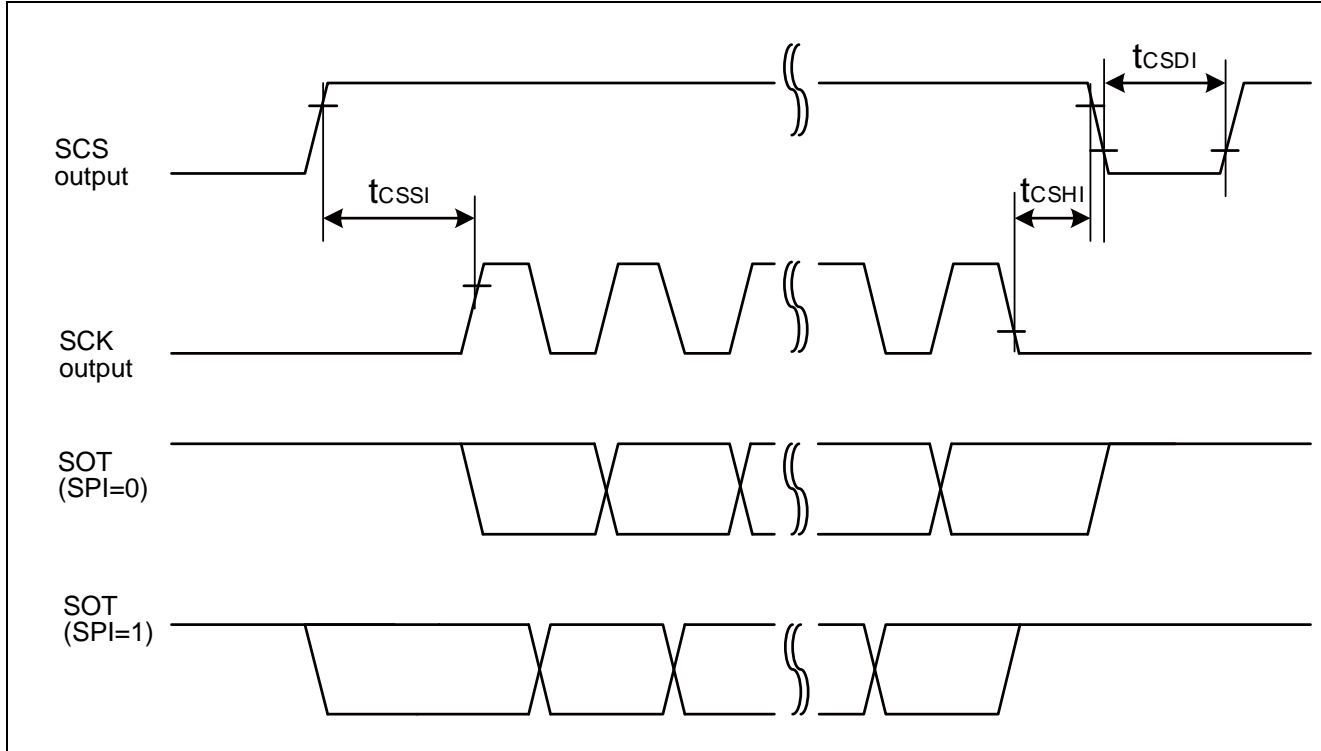

High-Speed Synchronous Serial (SPI = 0, SCINV = 0)

 (V_{CC} = 2.7V to 5.5V, V_{SS} = 0V)

| Parameter | Symbol | Pin Name | Conditions | V _{CC} < 4.5V | | V _{CC} ≥ 4.5V | | Unit |
|----------------------------|--------------------|------------|--------------------------------|------------------------|------|------------------------|------|------|
| | | | | Min | Max | Min | Max | |
| Baud rate | - | - | - | - | 22.5 | - | 22.5 | Mbps |
| Serial clock cycle time | t _{SCYC} | SCKx | Internal shift clock operation | 4t _{CYCP} | - | 4t _{CYCP} | - | ns |
| SCK↓→SOT delay time | t _{SLOVI} | SCKx, SOTx | | - 10 | + 10 | - 10 | + 10 | ns |
| SIN→SCK↑ setup time | t _{IVSHI} | SCKx, SINx | | 14 | - | 12.5 | - | ns |
| | | | | 12.5* | | | | |
| SCK↑→SIN hold time | t _{SHIXI} | SCKx, SINx | | 5 | - | 5 | - | ns |
| Serial clock L pulse width | t _{SLSH} | SCKx | External shift clock operation | 2t _{CYCP} - 5 | - | 2t _{CYCP} - 5 | - | ns |
| Serial clock H pulse width | t _{SHSL} | SCKx | | t _{CYCP} + 10 | - | t _{CYCP} + 10 | - | ns |
| SCK↓→SOT delay time | t _{SLOVE} | SCKx, SOTx | | - | 15 | - | 15 | ns |
| SIN→SCK↑ setup time | t _{IVSHE} | SCKx, SINx | | 5 | - | 5 | - | ns |
| SCK↑→SIN hold time | t _{SHIXE} | SCKx, SINx | | 5 | - | 5 | - | ns |
| SCK fall time | t _F | SCKx | | - | 5 | - | 5 | ns |
| SCK rise time | t _R | SCKx | | - | 5 | - | 5 | ns |

Notes:

- The above characteristics apply to CLK synchronous mode.
- t_{CYCP} indicates the APB bus clock cycle time. For more information about the APB bus number to which the multi-function serial is connected, see 8. Block Diagram in this data sheet.
- These characteristics only guarantee the following pins:
 - No chip select: SIN4_0, SOT4_0, SCK4_0
 - Chip select: SIN6_0, SOT6_0, SCK6_0, SCS60_0, SCS61_0, SCS62_0, SCS63_0
- When the external load capacitance C_L = 30 pF. (For *, when C_L = 10 pF)

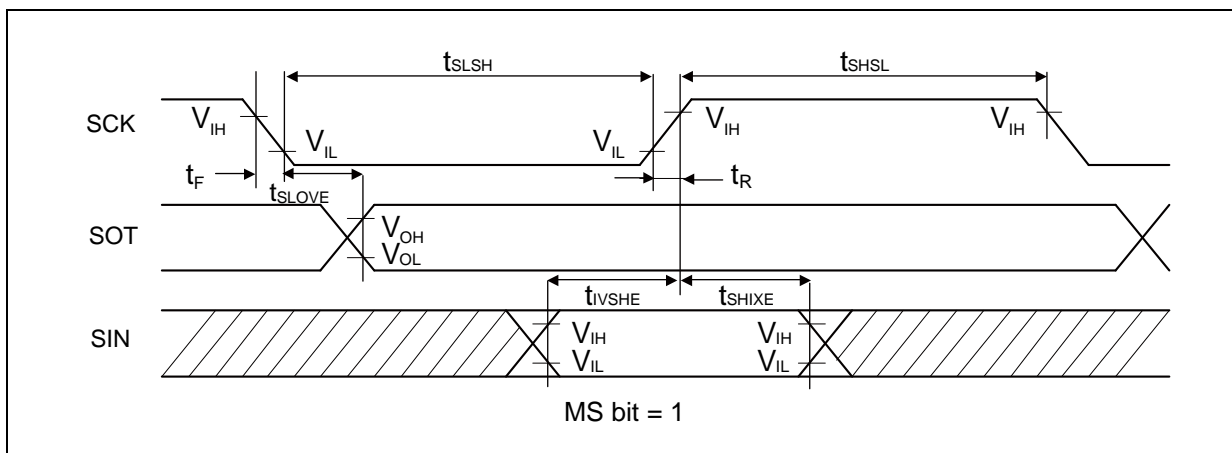
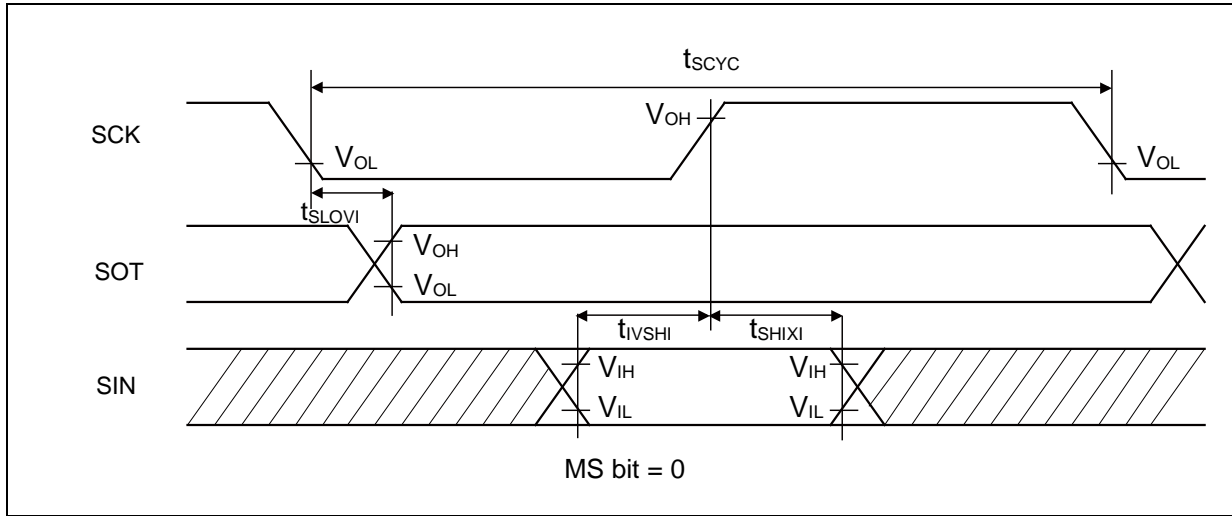

High-Speed Synchronous Serial (SPI = 0, SCINV = 1)

 (V_{CC} = 2.7V to 5.5V, V_{SS} = 0V)

| Parameter | Symbol | Pin Name | Conditions | V _{CC} < 4.5 V | | V _{CC} ≥ 4.5 V | | Unit |
|----------------------------|--------------------|-------------------------------------|--------------------------------|-------------------------|------|-------------------------|------|------|
| | | | | Min | Max | Min | Max | |
| Baud rate | - | - | - | - | 22.5 | - | 22.5 | Mbps |
| Serial clock cycle time | t _{SCYC} | SCK _X | Internal shift clock operation | 4t _{CYCP} | - | 4t _{CYCP} | - | ns |
| SCK↑→SOT delay time | t _{SHOVI} | SCK _X , SOT _X | | - 10 | + 10 | - 10 | + 10 | ns |
| SIN→SCK↓ setup time | t _{IVSLI} | SCK _X , SIN _X | | 14 | - | 12.5 | - | ns |
| | | | | 12.5* | | | | |
| SCK↓→SIN hold time | t _{SLIXI} | SCK _X , SIN _X | | 5 | - | 5 | - | ns |
| Serial clock L pulse width | t _{SLSH} | SCK _X | External shift clock operation | 2t _{CYCP} - 5 | - | 2t _{CYCP} - 5 | - | ns |
| Serial clock H pulse width | t _{SHSL} | SCK _X | | t _{CYCP} + 10 | - | t _{CYCP} + 10 | - | ns |
| SCK↑→SOT delay time | t _{SHOVE} | SCK _X , SOT _X | | - | 15 | - | 15 | ns |
| SIN→SCK↓ setup time | t _{IVSLE} | SCK _X , SIN _X | | 5 | - | 5 | - | ns |
| SCK↓→SIN hold time | t _{SLIXE} | SCK _X , SIN _X | | 5 | - | 5 | - | ns |
| SCK fall time | t _F | SCK _X | | - | 5 | - | 5 | ns |
| SCK rise time | t _R | SCK _X | | - | 5 | - | 5 | ns |

Notes:

- The above characteristics apply to CLK synchronous mode.
- t_{CYCP} indicates the APB bus clock cycle time. For more information about the APB bus number to which the multi-function serial is connected, see 8. Block Diagram in this data sheet.
- These characteristics only guarantee the following pins:
 - No chip select: SIN4_0, SOT4_0, SCK4_0
 - Chip select: SIN6_0, SOT6_0, SCK6_0, SCS60_0, SCS61_0, SCS62_0, SCS63_0
- When the external load capacitance C_L = 30 pF. (For *, when C_L = 10 pF)

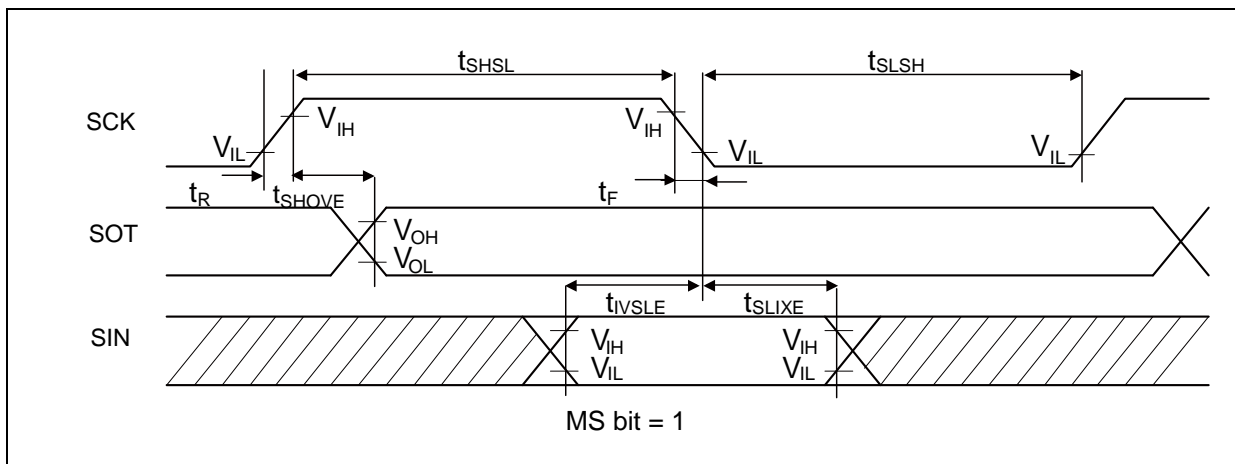
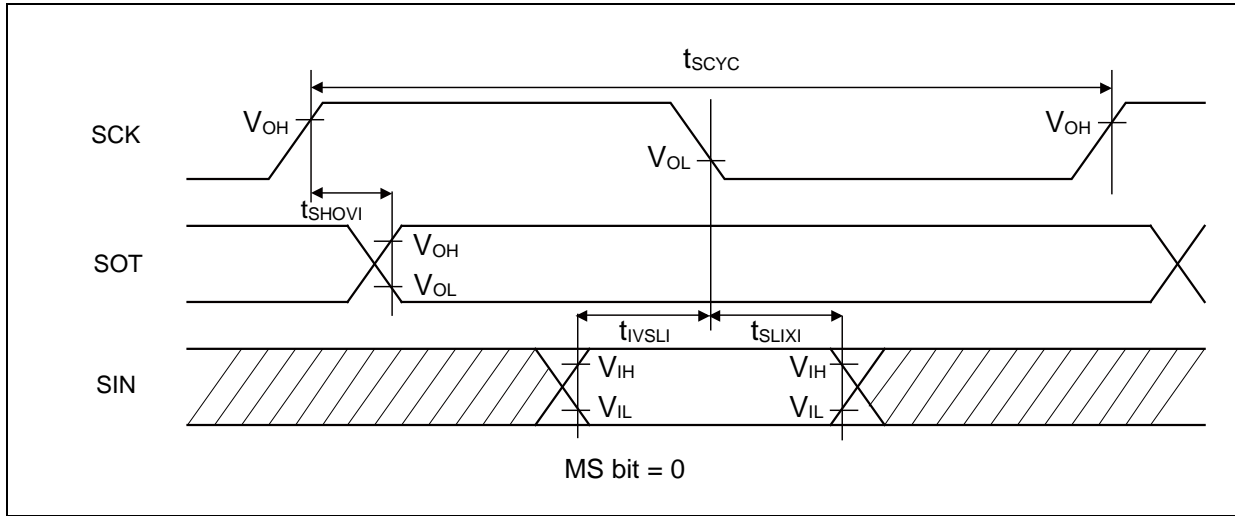

High-Speed Synchronous Serial (SPI = 1, SCINV = 0)

(V_{CC} = 2.7V to 5.5V, V_{SS} = 0V)

| Parameter | Symbol | Pin Name | Conditions | V _{CC} < 4.5 V | | V _{CC} ≥ 4.5 V | | Unit |
|----------------------------|--------------------|-------------------------------------|--------------------------------|-------------------------|------|-------------------------|------|------|
| | | | | Min | Max | Min | Max | |
| Baud rate | - | - | - | - | 22.5 | - | 22.5 | Mbps |
| Serial clock cycle time | t _{SCYC} | SCK _X | Internal shift clock operation | 4t _{CYCP} | - | 4t _{CYCP} | - | ns |
| SCK↑→SOT delay time | t _{SHOVI} | SCK _X , SOT _X | | - 10 | + 10 | - 10 | + 10 | ns |
| SIN→SCK↓ setup time | t _{IVSLI} | SCK _X , SIN _X | | 14 | - | 12.5 | - | ns |
| | | | | 12.5* | | | | |
| SCK↓→SIN hold time | t _{SLIXI} | SCK _X , SIN _X | | 5 | - | 5 | - | ns |
| SOT→SCK↓ delay time | t _{SOVLI} | SCK _X , SOT _X | | 2t _{CYCP} - 10 | - | 2t _{CYCP} - 10 | - | ns |
| Serial clock L pulse width | t _{SLSH} | SCK _X | External shift clock operation | 2t _{CYCP} - 5 | - | 2t _{CYCP} - 5 | - | ns |
| Serial clock H pulse width | t _{SHSL} | SCK _X | | t _{CYCP} + 10 | - | t _{CYCP} + 10 | - | ns |
| SCK↑→SOT delay time | t _{SHOVE} | SCK _X , SOT _X | | - | 15 | - | 15 | ns |
| SIN→SCK↓ setup time | t _{IVSLE} | SCK _X , SIN _X | | 5 | - | 5 | - | ns |
| SCK↓→SIN hold time | t _{SLIXE} | SCK _X , SIN _X | | 5 | - | 5 | - | ns |
| SCK fall time | t _F | SCK _X | | - | 5 | - | 5 | ns |
| SCK rise time | t _R | SCK _X | | - | 5 | - | 5 | ns |

Notes:

- The above characteristics apply to CLK synchronous mode.
- t_{CYCP} indicates the APB bus clock cycle time. For more information about the APB bus number to which the multi-function serial is connected, see 8. Block Diagram in this data sheet.
- These characteristics only guarantee the following pins:
 - No chip select: SIN4_0, SOT4_0, SCK4_0
 - Chip select: SIN6_0, SOT6_0, SCK6_0, SCS60_0, SCS61_0, SCS62_0, SCS63_0
- When the external load capacitance C_L = 30 pF. (for *, when C_L = 10 pF)

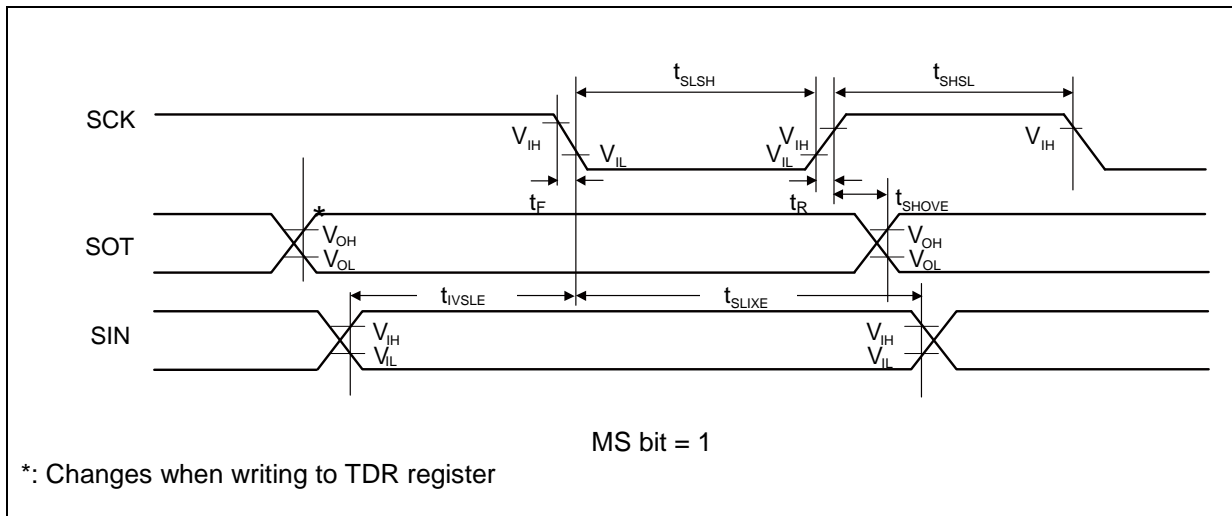
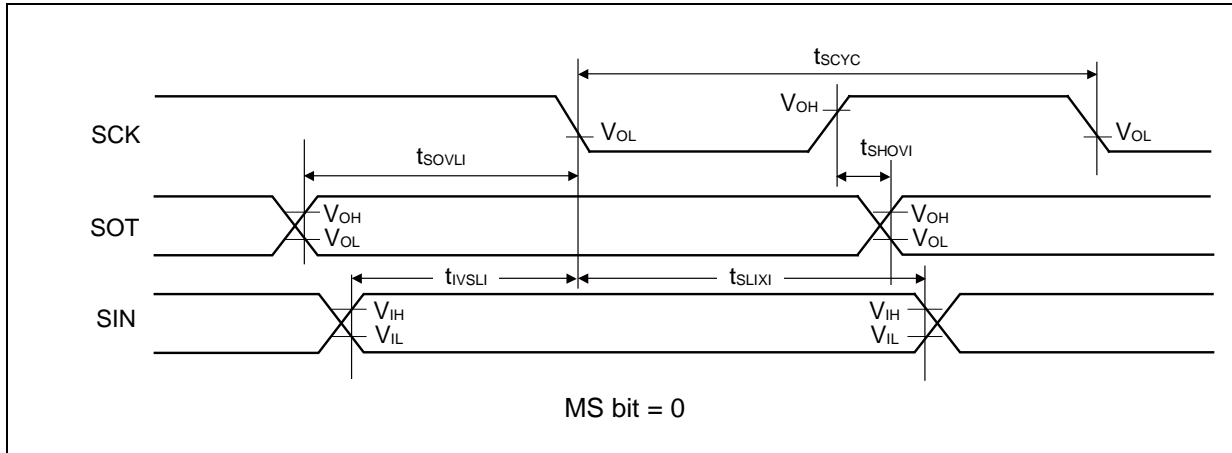

High-Speed Synchronous Serial (SPI = 1, SCINV = 1)

 (V_{CC} = 2.7V to 5.5V, V_{SS} = 0V)

| Parameter | Symbol | Pin Name | Conditions | V _{CC} < 4.5 V | | V _{CC} ≥ 4.5 V | | Unit |
|----------------------------|--------------------|-------------------------------------|--------------------------------|-------------------------|------|-------------------------|------|------|
| | | | | Min | Max | Min | Max | |
| Baud rate | - | - | - | - | 22.5 | - | 22.5 | Mbps |
| Serial clock cycle time | t _{SCYC} | SCK _X | Internal shift clock operation | 4t _{CYCP} | - | 4t _{CYCP} | - | ns |
| SCK↓→SOT delay time | t _{SLOVI} | SCK _X , SOT _X | | - 10 | + 10 | - 10 | + 10 | ns |
| SIN→SCK↑ setup time | t _{IVSHI} | SCK _X , SIN _X | | 14 | - | 12.5 | - | ns |
| | | | | 12.5* | | | | |
| SCK↑→SIN hold time | t _{SHIXI} | SCK _X , SIN _X | | 5 | - | 5 | - | ns |
| SOT→SCK↑ delay time | t _{SOVHI} | SCK _X , SOT _X | | 2t _{CYCP} - 10 | - | 2t _{CYCP} - 10 | - | ns |
| Serial clock L pulse width | t _{SLSH} | SCK _X | External shift clock operation | 2t _{CYCP} - 5 | - | 2t _{CYCP} - 5 | - | ns |
| Serial clock H pulse width | t _{SHSL} | SCK _X | | t _{CYCP} + 10 | - | t _{CYCP} + 10 | - | ns |
| SCK↓→SOT delay time | t _{SLOVE} | SCK _X , SOT _X | | - | 15 | - | 15 | ns |
| SIN→SCK↑ setup time | t _{IVSHE} | SCK _X , SIN _X | | 5 | - | 5 | - | ns |
| SCK↑→SIN hold time | t _{SHIXE} | SCK _X , SIN _X | | 5 | - | 5 | - | ns |
| SCK fall time | t _F | SCK _X | | - | 5 | - | 5 | ns |
| SCK rise time | t _R | SCK _X | | - | 5 | - | 5 | ns |

Notes:

- The above characteristics apply to CLK synchronous mode.
- t_{CYCP} indicates the APB bus clock cycle time. For more information about the APB bus number to which the multi-function serial is connected, see 8. Block Diagram in this data sheet.
- These characteristics only guarantee the following pins:
 - No chip select: SIN4_0, SOT4_0, SCK4_0
 - Chip select: SIN6_0, SOT6_0, SCK6_0, SCS60_0, SCS61_0, SCS62_0, SCS63_0
- When the external load capacitance C_L = 30 pF. (for *, when C_L = 10 pF)

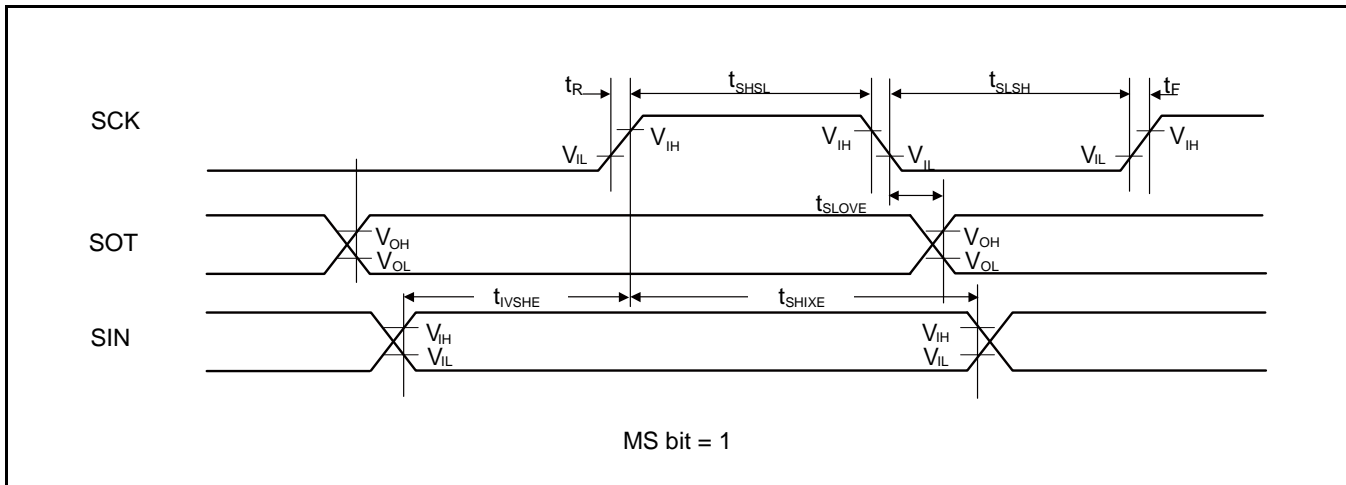
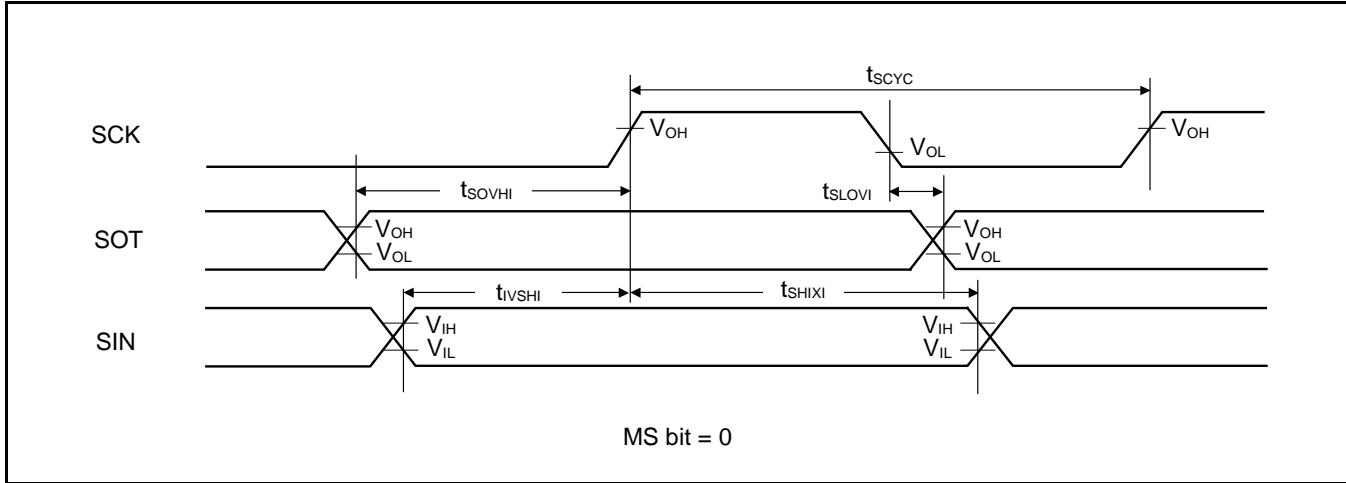

When Using High-Speed Synchronous Serial Chip Select (SPI = 1, SCINV = 0, MS = 0, CSLVL = 1)

(V_{CC} = 2.7V to 5.5V, V_{SS} = 0V)

| Parameter | Symbol | Conditions | V _{CC} < 4.5 V | | V _{CC} ≥ 4.5 V | | Unit |
|----------------------|-------------------|--------------------------------|--------------------------------|--------------------------------|--------------------------------|--------------------------------|------|
| | | | Min | Max | Min | Max | |
| SCS↓→SCK↓ setup time | t _{CSSI} | Internal shift clock operation | (*1)-20 | (*1)+0 | (*1)-20 | (*1)+0 | ns |
| SCK↑→SCS↑ hold time | t _{CShI} | | (*2)+0 | (*2)+20 | (*2)+0 | (*2)+20 | ns |
| SCS deselect time | t _{CSDI} | | (*3)-20 +5t _{CYCP} | (*3)+20 +5t _{CYCP} | (*3)-20 +5t _{CYCP} | (*3)+20 +5t _{CYCP} | ns |
| SCS↓→SCK↓ setup time | t _{CSE} | External shift clock operation | 3t _{CYCP} +15 | - | 3t _{CYCP} +15 | - | ns |
| SCK↑→SCS↑ hold time | t _{CSE} | | 0 | - | 0 | - | ns |
| SCS deselect time | t _{CSE} | | 3t _{CYCP} +15 | - | 3t _{CYCP} +15 | - | ns |
| SCS↓→SOT delay time | t _{DSE} | | - | 25 | - | 25 | ns |
| SCS↑→SOT delay time | t _{DEE} | | 0 | - | 0 | - | ns |

(*1): CSSU bit value × serial chip select timing operating clock cycle [ns]

(*2): CSHD bit value × serial chip select timing operating clock cycle [ns]

(*3): CSDS bit value × serial chip select timing operating clock cycle [ns]

Notes:

- t_{CYCP} indicates the APB bus clock cycle time. For more information about the APB bus number to which the multi-function serial is connected, see 8. Block Diagram in this data sheet.
- For more information about CSSU, CSHD, CSDS, and the serial chip select timing operating clock, see FM4 Family Peripheral Manual Main Part (MN709-00001).
- When the external load capacitance C_L = 30 pF.

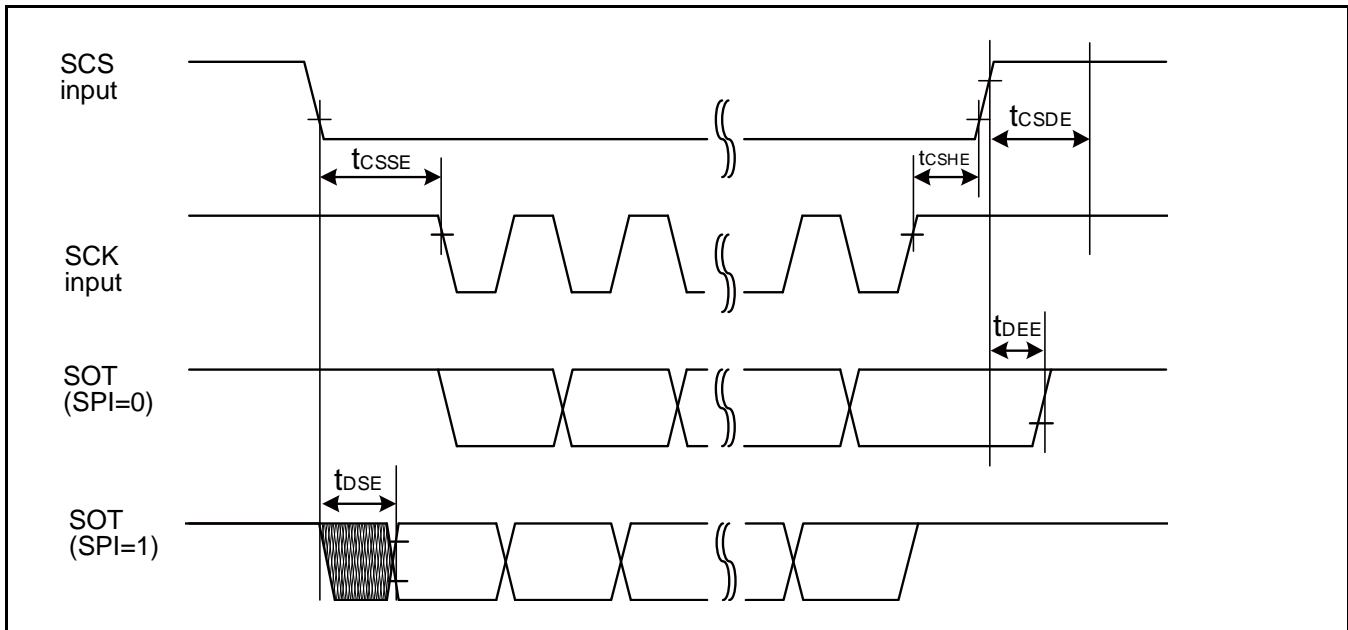
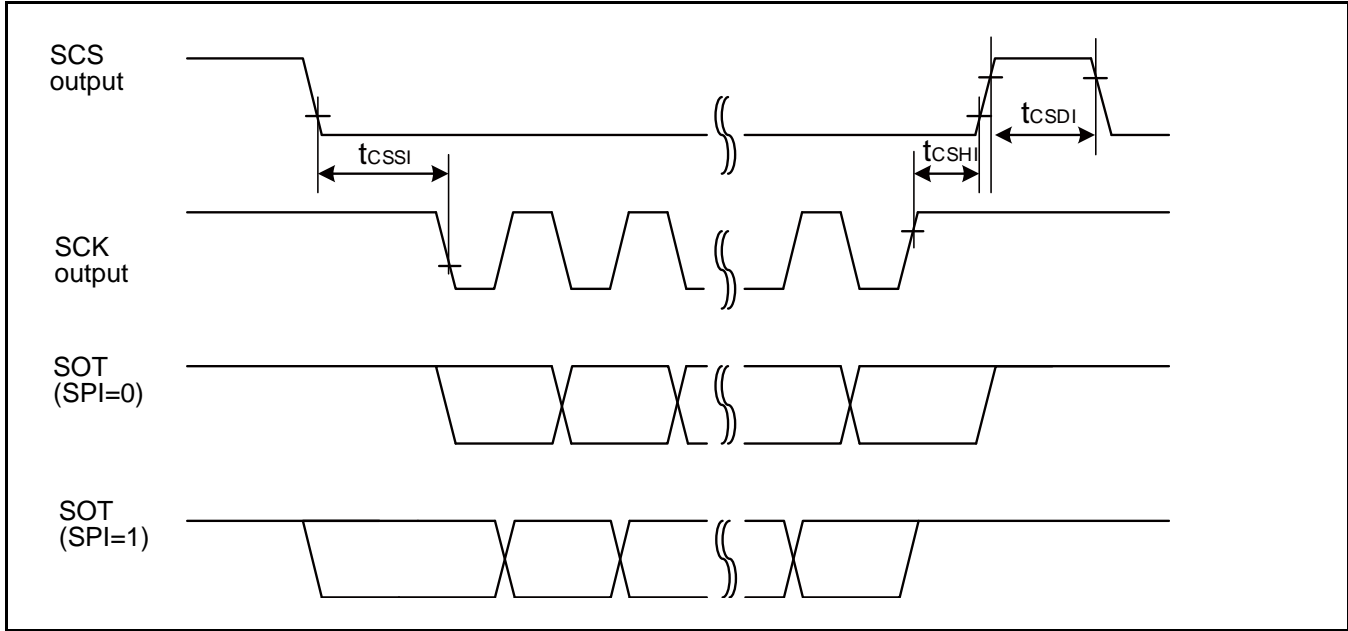

When Using High-Speed Synchronous Serial Chip Select (SPI = 1, SCINV = 1, MS = 0, CSLVL = 1)

 (V_{CC} = 2.7V to 5.5V, V_{SS} = 0V)

| Parameter | Symbol | Conditions | V _{CC} < 4.5 V | | V _{CC} ≥ 4.5 V | | Unit |
|----------------------|-------------------|--------------------------------|--------------------------------|--------------------------------|--------------------------------|--------------------------------|------|
| | | | Min | Min | Min | Max | |
| SCS↓→SCK↓ setup time | t _{CSSI} | Internal shift clock operation | (*1)-20 | (*1)+0 | (*1)-20 | (*1)+0 | ns |
| SCK↑→SCS↑ hold time | t _{CShI} | | (*2)+0 | (*2)+20 | (*2)+0 | (*2)+20 | ns |
| SCS deselect time | t _{CSDI} | | (*3)-20 +5t _{CYCP} | (*3)+20 +5t _{CYCP} | (*3)-20 +5t _{CYCP} | (*3)+20 +5t _{CYCP} | ns |
| SCS↓→SCK↑ setup time | t _{CSE} | External shift clock operation | 3t _{CYCP} +15 | - | 3t _{CYCP} +15 | - | ns |
| SCK↑→SCS↑ hold time | t _{CSE} | | 0 | - | 0 | - | ns |
| SCS deselect time | t _{CSE} | | 3t _{CYCP} +15 | - | 3t _{CYCP} +15 | - | ns |
| SCS↓→SOT delay time | t _{DSE} | | - | 25 | - | 25 | ns |
| SCS↑→SOT delay time | t _{DEE} | | 0 | - | 0 | - | ns |

(*1): CSSU bit value × serial chip select timing operating clock cycle [ns]

(*2): CSHD bit value × serial chip select timing operating clock cycle [ns]

(*3): CSDS bit value × serial chip select timing operating clock cycle [ns]

Notes:

- t_{CYCP} indicates the APB bus clock cycle time. For more information about the APB bus number to which the multi-function serial is connected, see 8. Block Diagram in this data sheet.
- For more information about CSSU, CSHD, CSDS, and the serial chip select timing operating clock, see FM4 Family Peripheral Manual Main Part (MN709-00001).
- When the external load capacitance C_L = 30 pF.

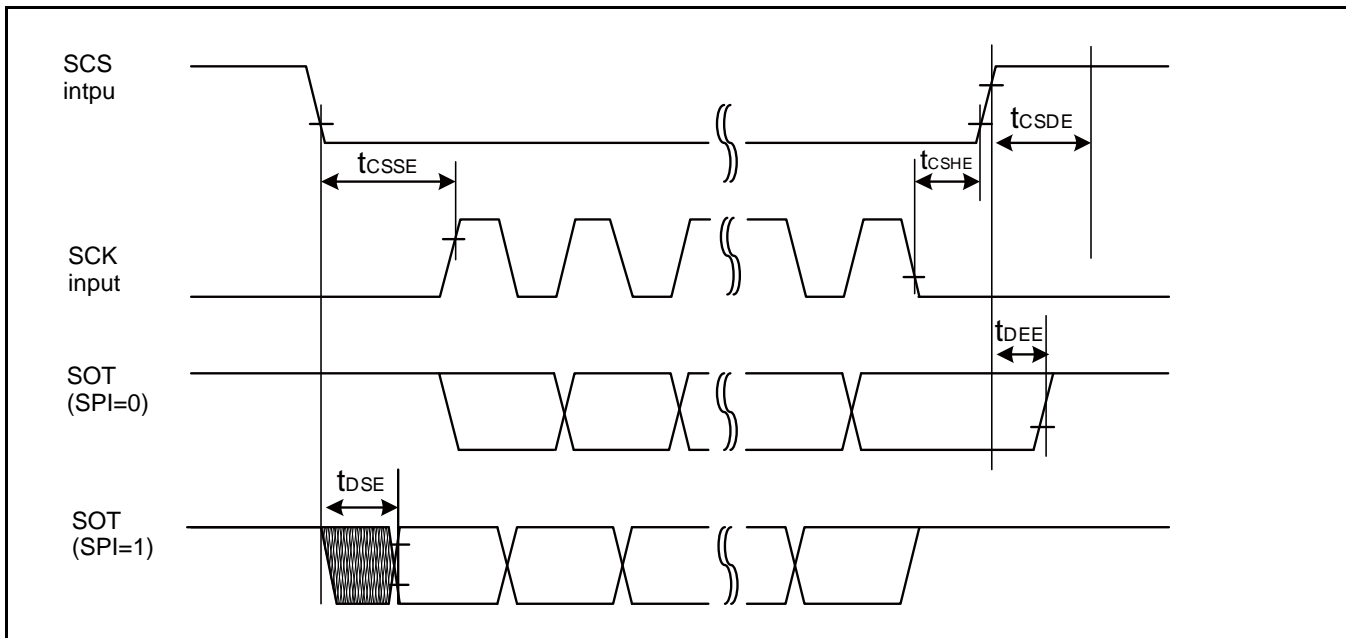
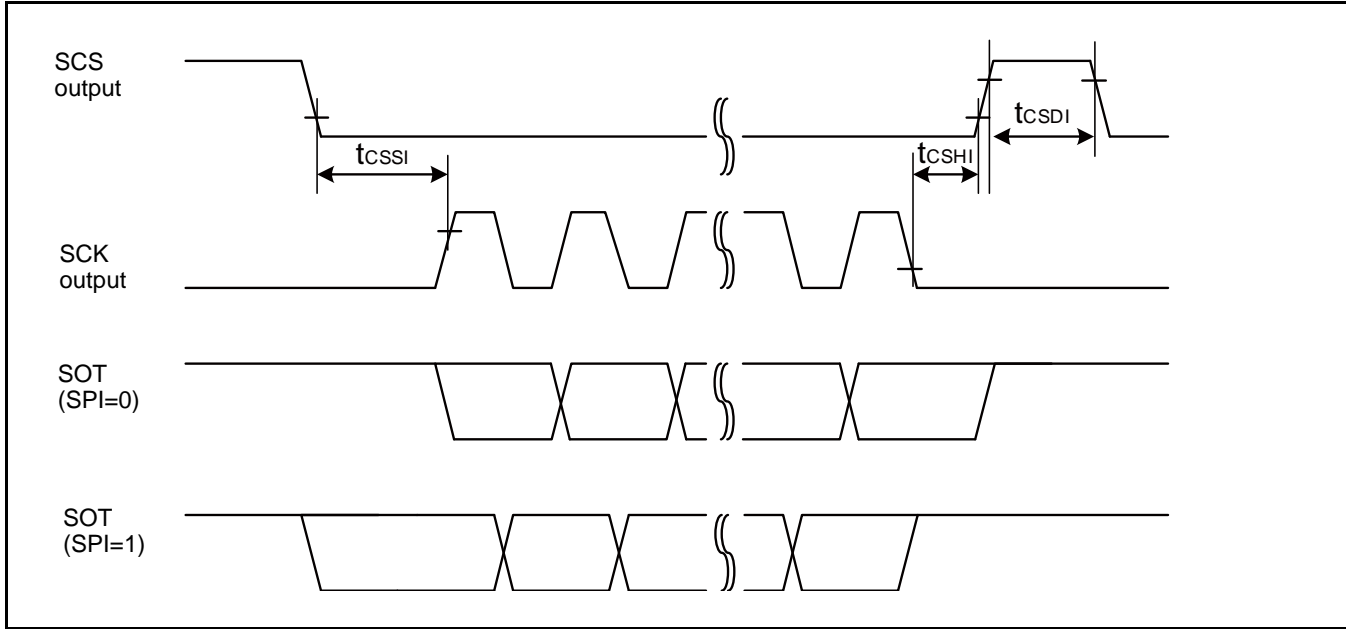

When Using High-Speed Synchronous Serial Chip Select (SPI = 1, SCINV = 0, MS = 0, CSLVL = 0)

(V_{CC} = 2.7V to 5.5V, V_{SS} = 0V)

| Parameter | Symbol | Conditions | V _{CC} < 4.5 V | | V _{CC} ≥ 4.5 V | | Unit |
|----------------------|-------------------|--------------------------------|--------------------------------|--------------------------------|--------------------------------|--------------------------------|------|
| | | | Min | Max | Min | Max | |
| SCS↑→SCK↓ setup time | t _{CSSI} | Internal shift clock operation | (*1)-20 | (*1)+0 | (*1)-20 | (*1)+0 | ns |
| SCK↑→SCS↓ hold time | t _{CShI} | | (*2)+0 | (*2)+20 | (*2)+0 | (*2)+20 | ns |
| SCS deselect time | t _{CSDI} | | (*3)-20 +5t _{CYCP} | (*3)+20 +5t _{CYCP} | (*3)-20 +5t _{CYCP} | (*3)+20 +5t _{CYCP} | ns |
| SCS↑→SCK↓ setup time | t _{CSE} | External shift clock operation | 3t _{CYCP} +15 | - | 3t _{CYCP} +15 | - | ns |
| SCK↑→SCS↓ hold time | t _{CSE} | | 0 | - | 0 | - | ns |
| SCS deselect time | t _{CSE} | | 3t _{CYCP} +15 | - | 3t _{CYCP} +15 | - | ns |
| SCS↑→SOT delay time | t _{DSE} | | - | 25 | - | 25 | ns |
| SCS↓→SOT delay time | t _{DEE} | | 0 | - | 0 | - | ns |

(*1): CSSU bit value × serial chip select timing operating clock cycle [ns]

(*2): CSHD bit value × serial chip select timing operating clock cycle [ns]

(*3): CSDS bit value × serial chip select timing operating clock cycle [ns]

Notes:

- t_{CYCP} indicates the APB bus clock cycle time. For more information about the APB bus number to which the multi-function serial is connected, see 8. Block Diagram in this data sheet.
- For more information about CSSU, CSHD, CSDS, and the serial chip select timing operating clock, see FM4 Family Peripheral Manual Main Part (MN709-00001).
- When the external load capacitance C_L = 30 pF.

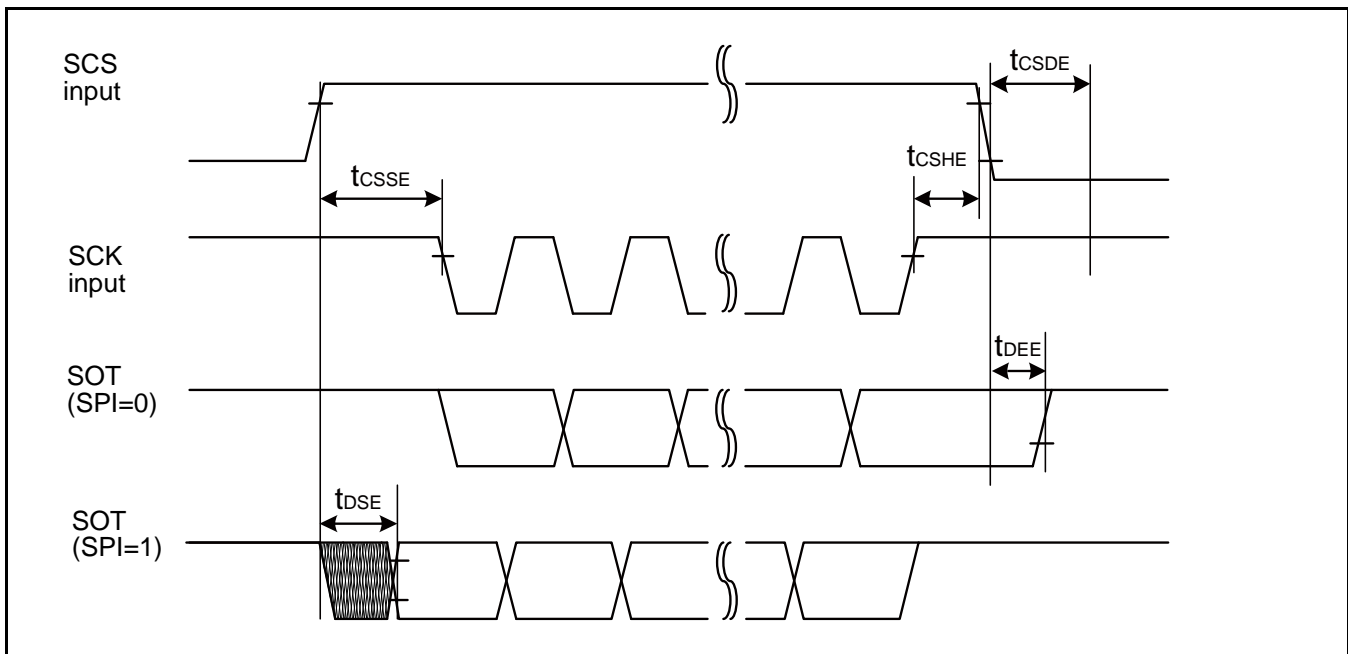
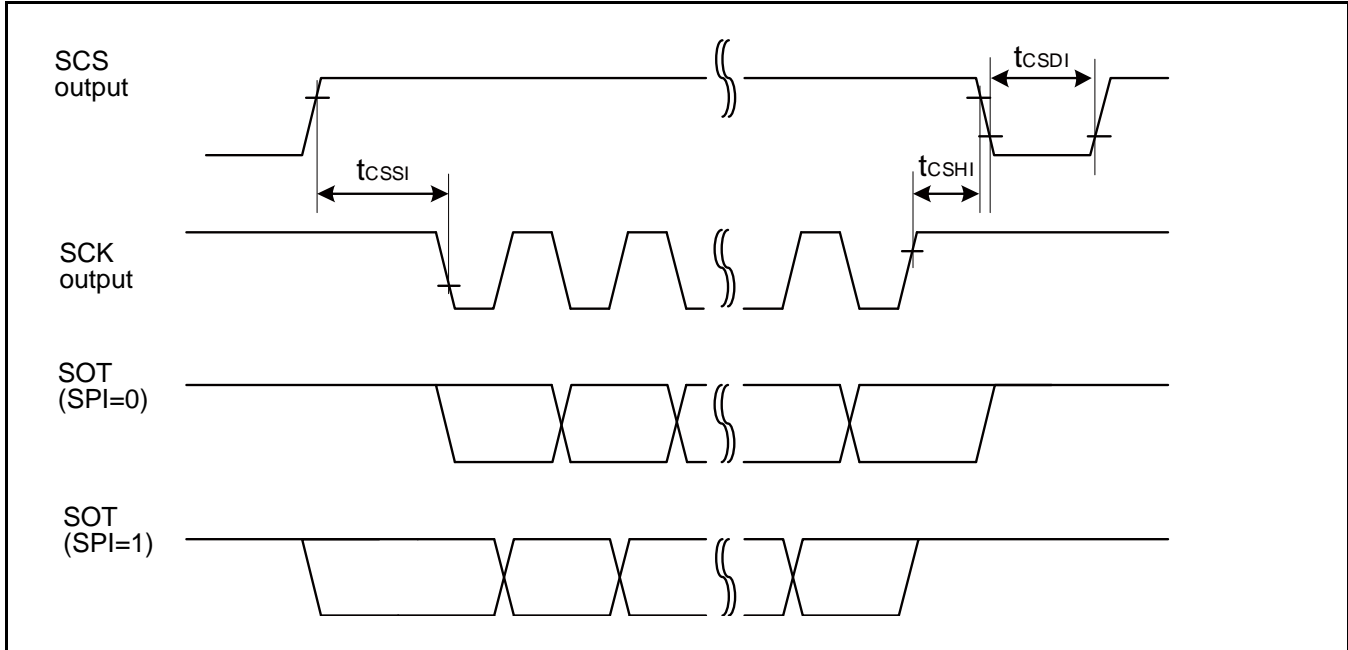

When Using High-Speed Synchronous Serial Chip Select (SPI = 1, SCINV = 1, MS = 0, CSLVL = 0)

(V_{CC} = 2.7V to 5.5V, V_{SS} = 0V)

| Parameter | Symbol | Conditions | V _{CC} < 4.5 V | | V _{CC} ≥ 4.5 V | | Unit |
|---|-------------------|--------------------------------|--------------------------------|--------------------------------|--------------------------------|--------------------------------|------|
| | | | Min | Max | Min | Max | |
| SCS _↓ →SCK _↓ setup time | t _{CSSI} | Internal shift clock operation | (*1)-20 | (*1)+0 | (*1)-20 | (*1)+0 | ns |
| SCK _↑ →SCS _↓ hold time | t _{CSHI} | | (*2)+0 | (*2)+20 | (*2)+0 | (*2)+20 | ns |
| SCS deselect time | t _{CSDI} | | (*3)-20 +5t _{CYCP} | (*3)+20 +5t _{CYCP} | (*3)-20 +5t _{CYCP} | (*3)+20 +5t _{CYCP} | ns |
| SCS _↑ →SCK _↑ setup time | t _{CSSE} | External shift clock operation | 3t _{CYCP} +15 | - | 3t _{CYCP} +15 | - | ns |
| SCK _↓ →SCS _↓ hold time | t _{CSHE} | | 0 | - | 0 | - | ns |
| SCS deselect time | t _{CSDE} | | 3t _{CYCP} +15 | - | 3t _{CYCP} +15 | - | ns |
| SCS _↑ →SOT delay time | t _{DSE} | | - | 40 | - | 40 | ns |
| SCS _↓ →SOT delay time | t _{DEE} | | 0 | - | 0 | - | ns |

(*1): CSSU bit value × serial chip select timing operating clock cycle [ns]

(*2): CSHD bit value × serial chip select timing operating clock cycle [ns]

(*3): CSDS bit value × serial chip select timing operating clock cycle [ns]

Notes:

- t_{CYCP} indicates the APB bus clock cycle time. For more information about the APB bus number to which the multi-function serial is connected, see 8. Block Diagram in this data sheet.
- For more information about CSSU, CSHD, CSDS, and the serial chip select timing operating clock, see FM4 Family Peripheral Manual Main Part (MN709-00001).
- When the external load capacitance C_L = 30 pF.

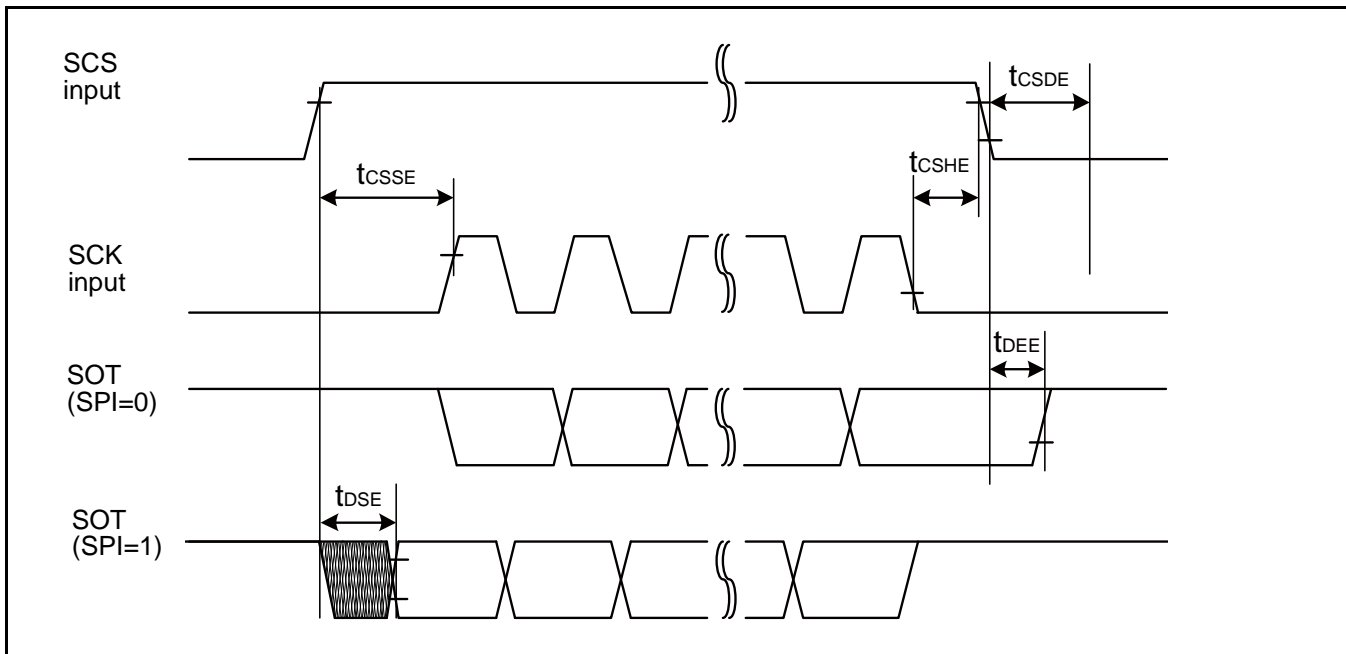
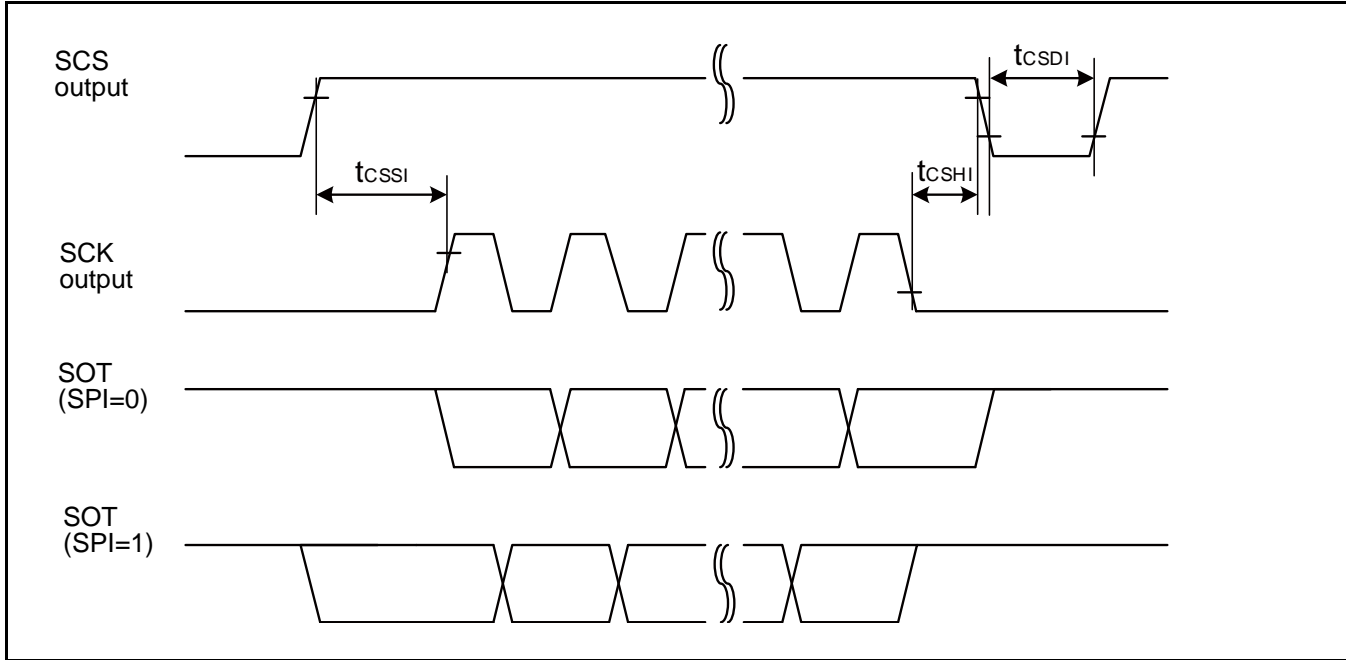

External Clock (EXT = 1): When in Asynchronous Mode Only

($V_{CC} = 2.7V$ to $5.5V$, $V_{SS} = 0V$)

| Parameter | Symbol | Condition | Value | | Unit | Remarks |
|----------------------------|------------|----------------------|-----------------|-----|------|---------|
| | | | Min | Max | | |
| Serial clock L pulse width | t_{SLSH} | $C_L = 30\text{ pF}$ | $t_{CYCP} + 10$ | - | ns | |
| Serial clock H pulse width | t_{SHSL} | | $t_{CYCP} + 10$ | - | ns | |
| SCK fall time | t_F | | - | 5 | ns | |
| SCK rise time | t_R | | - | 5 | ns | |

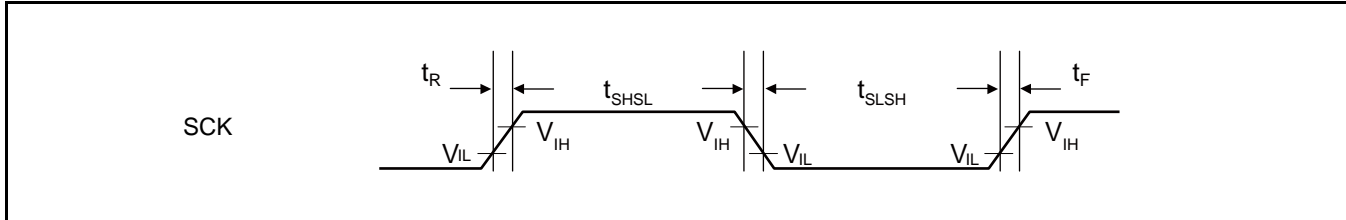

12.4.13 External Input Timing

 (V_{CC} = 2.7V to 5.5V, V_{SS} = 0V)

| Parameter | Symbol | Pin Name | Conditions | Value | | Unit | Remarks |
|-------------------|-------------------------------------|----------------------|------------|--|----------------------|------|-----------------------------|
| | | | | Min | Max | | |
| Input pulse width | t _{INH} , t _{INL} | ADTGx | - | 2t _{CYCP} ^{*1} | - | ns | A/D converter trigger input |
| | | FRCKx | | | | | Free-run timer input clock |
| | | ICxx | | | | | Input capture |
| | | DTTIXX | - | 2t _{CYCP} ^{*1} | - | ns | Waveform generator |
| | | INT00 to INT31, NMIX | - | 2t _{CYCP} + 100 ^{*1} | - | ns | External interrupt, NMI |
| | | | | | | | |
| WKUPx | - | 500 ^{*3} | - | ns | Deep standby wake up | | |

1: t_{CYCP} indicates the APB bus clock cycle time except stop when in Stop mode, in Timer mode. For more information about the APB bus number to which the A/D converter, multi-function timer, and external interrupt are connected, see 8. Block Diagram in this data sheet.

2: When in Stop mode, in Timer mode

3: When in Deep Standby RTC mode, in Deep Standby Stop mode

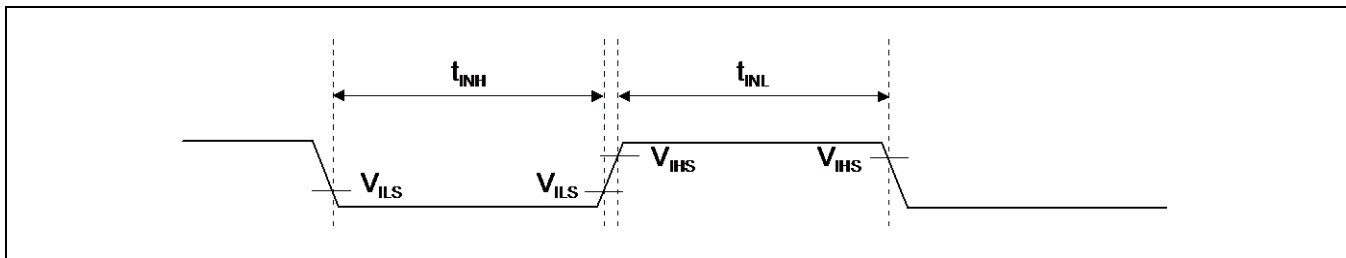

12.4.14 Quadrature Position/Revolution Counter Timing

($V_{CC} = AV_{CC} = 2.7V$ to $5.5V$, $V_{SS} = AV_{SS} = 0V$, $T_a = -40^{\circ}C$ to $+105^{\circ}C$)

| Parameter | Symbol | Conditions | Value | | Unit |
|--|------------|----------------------|---------------|-----|------|
| | | | Min | Max | |
| AIN pin H width | t_{AHL} | - | $2t_{CYCP}^*$ | - | ns |
| AIN pin L width | t_{ALL} | - | | | |
| BIN pin H width | t_{BHL} | - | | | |
| BIN pin L width | t_{BLL} | - | | | |
| BIN rise time from AIN pin H level | t_{AUBU} | PC_Mode2 or PC_Mode3 | | | |
| AIN fall time from BIN pin H level | t_{BUAD} | PC_Mode2 or PC_Mode3 | | | |
| BIN fall time from AIN pin L level | t_{ADBD} | PC_Mode2 or PC_Mode3 | | | |
| AIN rise time from BIN pin L level | t_{BDAU} | PC_Mode2 or PC_Mode3 | | | |
| AIN rise time from BIN pin H level | t_{BUAU} | PC_Mode2 or PC_Mode3 | | | |
| BIN fall time from AIN pin H level | t_{AUBD} | PC_Mode2 or PC_Mode3 | | | |
| AIN fall time from BIN pin L level | t_{BDAD} | PC_Mode2 or PC_Mode3 | | | |
| BIN rise time from AIN pin L level | t_{ADBU} | PC_Mode2 or PC_Mode3 | | | |
| ZIN pin H width | t_{ZHL} | QCR: CGSC = 0 | | | |
| ZIN pin L width | t_{ZLL} | QCR: CGSC = 0 | | | |
| AIN/BIN rise and fall time from determined ZIN level | t_{ZABE} | QCR: CGSC = 1 | | | |
| Determined ZIN level from AIN/BIN rise and fall time | t_{ABEZ} | QCR: CGSC = 1 | | | |

*: t_{CYCP} indicates the APB bus clock cycle time except when in Stop mode, in Timer mode. For more information about the APB bus number to which the quadrature position/revolution counter is connected, see 8. Block Diagram in this data sheet.

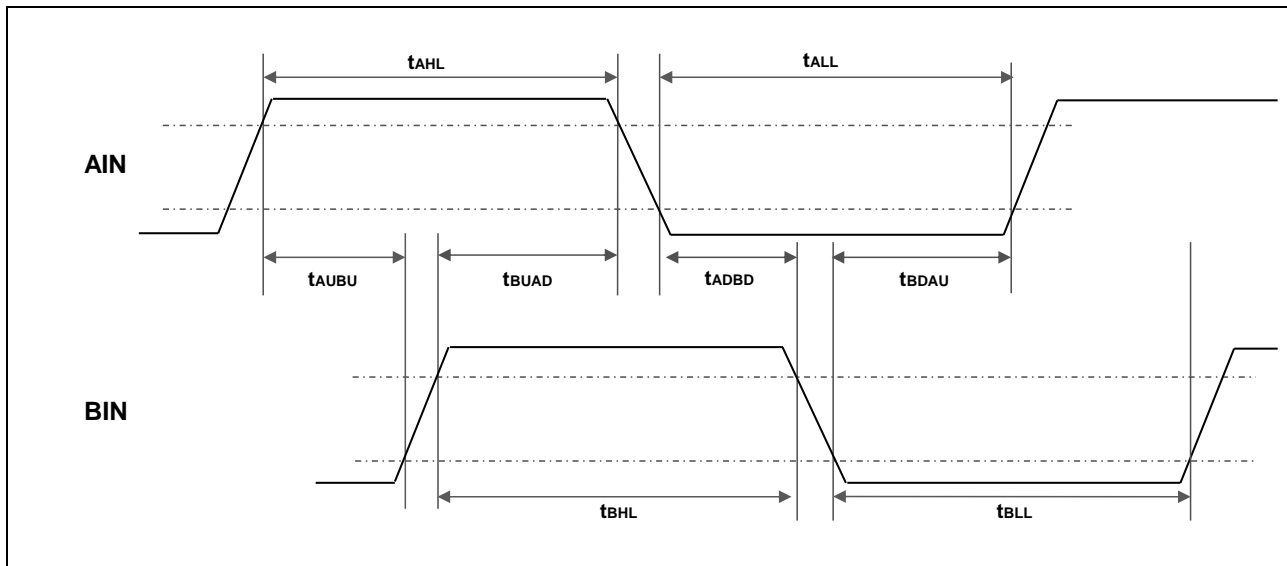

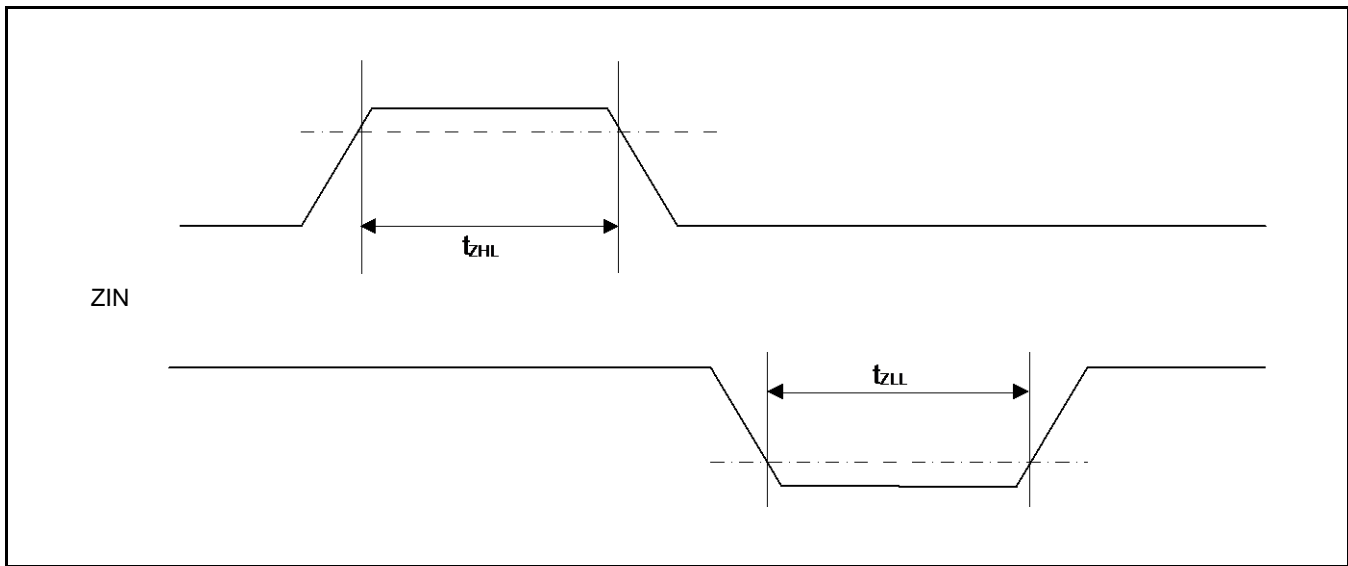
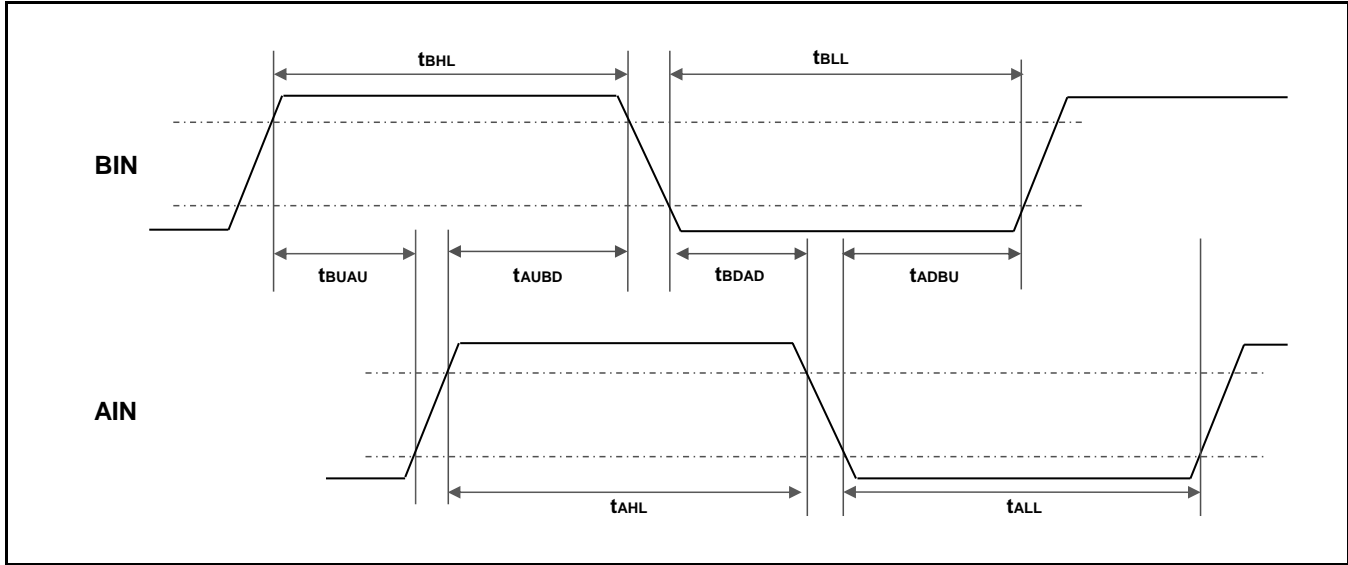

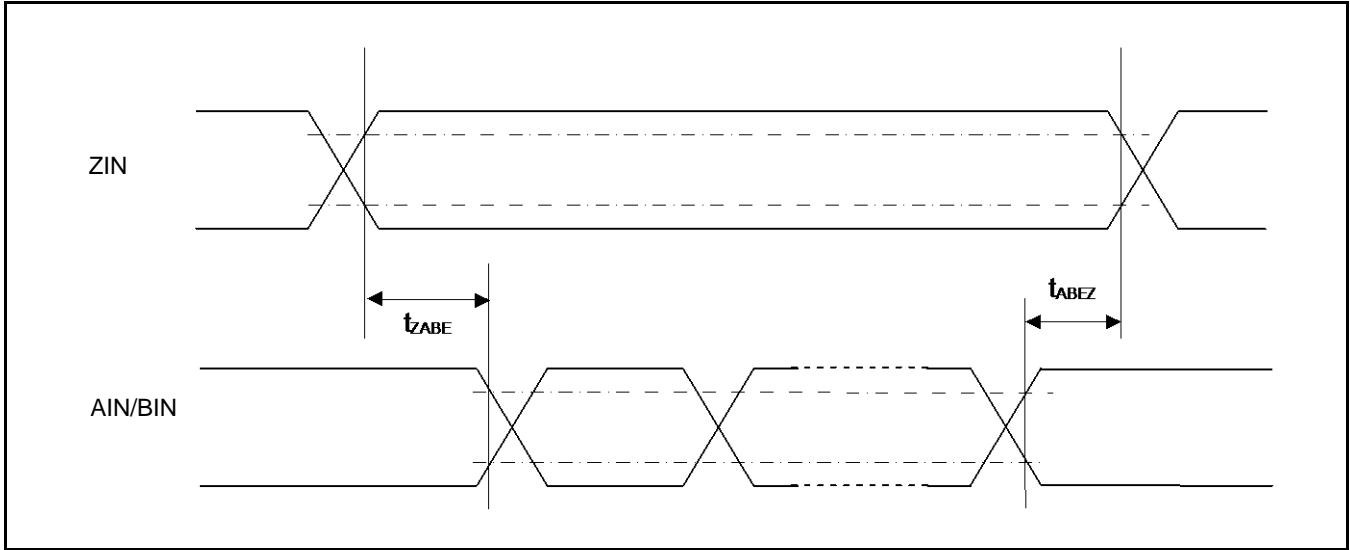

12.4.15 I²C Timing

Standard-Mode, Fast-Mode

(V_{CC} = 2.7V to 5.5V, V_{SS} = 0V)

| Parameter | Symbol | Conditions | Standard-Mode | | Fast-Mode | | Unit | Remarks |
|--|--------------------|---|------------------------------------|-----------------------------------|-----------------------------------|-----------------------------------|------|---------|
| | | | Min | Max | Min | Max | | |
| SCL clock frequency | f _{SCL} | C _L = 30 pF, R = (V _p /I _{OL}) ^{*1} | 0 | 100 | 0 | 400 | kHz | |
| (Repeated) START condition hold time SDA ↓ → SCL ↓ | t _{HDSTA} | | 4.0 | - | 0.6 | - | μs | |
| SCL clock L width | t _{LOW} | | 4.7 | - | 1.3 | - | μs | |
| SCL clock H width | t _{HIGH} | | 4.0 | - | 0.6 | - | μs | |
| (Repeated) START condition setup time SCL ↑ → SDA ↓ | t _{SUSTA} | | 4.7 | - | 0.6 | - | μs | |
| Data hold time SCL ↓ → SDA ↓ ↑ | t _{HDDAT} | | 0 | 3.45 ^{*2} | 0 | 0.9 ^{*3} | μs | |
| Data setup time SDA ↓ ↑ → SCL ↑ | t _{SUDAT} | | 250 | - | 100 | - | ns | |
| Stop condition setup time SCL ↑ → SDA ↑ | t _{SUSTO} | | 4.0 | - | 0.6 | - | μs | |
| Bus free time between "Stop condition" and "START condition" | t _{BUF} | | 4.7 | - | 1.3 | - | μs | |
| Noise filter | t _{SP} | | 2 MHz ≤ t _{CYCP} < 40 MHz | 2 t _{CYCP} ^{*4} | - | 2 t _{CYCP} ^{*4} | - | ns |
| | | 40 MHz ≤ t _{CYCP} < 60 MHz | 4 t _{CYCP} ^{*4} | - | 4 t _{CYCP} ^{*4} | - | ns | |
| | | 60 MHz ≤ t _{CYCP} < 80 MHz | 6 t _{CYCP} ^{*4} | - | 6 t _{CYCP} ^{*4} | - | ns | |
| | | 80 MHz ≤ t _{CYCP} ≤ 100 MHz | 8 t _{CYCP} ^{*4} | - | 8 t _{CYCP} ^{*4} | - | ns | |

- 1: R and C_L represent the pull-up resistance and load capacitance of the SCL and SDA lines, respectively. V_p indicates the power supply voltage of the pull-up resistance and I_{OL} indicates V_{OL} guaranteed current.
- 2: The maximum t_{HDDT} must not extend beyond the low period (t_{LOW}) of the device's SCL signal.
- 3: Fast-mode I²C bus device can be used on a Standard-mode I²C bus system as long as the device satisfies the requirement of t_{SUDAT} ≥ 250 ns.
- 4: t_{CYCP} is the APB bus clock cycle time. For more information about the APB bus number to which the I²C is connected, see 8.Block Diagram in this data sheet.
When using Standard-mode, the peripheral bus clock must be set more than 2 MHz.
When using Fast-mode, the peripheral bus clock must be set more than 8 MHz.
- 5: The noise filter time can be changed by register settings. Change the number of the noise filter steps according to the APB bus clock frequency.

Fast Mode Plus (Fm+)

(V_{CC} = 2.7V to 5.5V, V_{SS} = 0V)

| Parameter | Symbol | Conditions | Fast Mode Plus (Fm+)*6 | | Unit | Remarks |
|--|--------------------|---|-------------------------------------|------------------------|------|---------|
| | | | Min | Max | | |
| SCL clock frequency | f _{SCL} | C _L = 30 pF, R = (V _p /I _{OL})*1 | 0 | 1000 | kHz | |
| (Repeated) Start condition hold time SDA ↓ → SCL ↓ | t _{HDSTA} | | 0.26 | - | μs | |
| SCL clock L width | t _{LOW} | | 0.5 | - | μs | |
| SCL clock H width | t _{HIGH} | | 0.26 | - | μs | |
| SCL clock frequency | t _{SUSTA} | | 0.26 | - | μs | |
| (Repeated) Start condition hold time SDA ↓ → SCL ↓ | t _{HDDAT} | | 0 | 0.45*2, *3 | μs | |
| Data setup time SDA ↓ ↑ → SCL ↑ | t _{SUDAT} | | 50 | - | ns | |
| Stop condition setup time SCL ↑ → SDA ↑ | t _{SUSTO} | | 0.26 | - | μs | |
| Bus free time between Stop condition and Start condition | t _{BUF} | | 0.5 | - | μs | |
| Noise filter | t _{SP} | | 60 MHz ≤ t _{CYCP} < 80 MHz | 6 t _{CYCP} *4 | - | ns |
| | | 80 MHz ≤ t _{CYCP} ≤ 100 MHz | 8 t _{CYCP} *4 | - | ns | |

- 1: R and C_L represent the pull-up resistance and load capacitance of the SCL and SDA lines, respectively. V_p indicates the power supply voltage of the pull-up resistance and I_{OL} indicates V_{OL} guaranteed current.
- 2: The maximum t_{HDDT} must not extend beyond the low period (t_{LOW}) of the device's SCL signal.
- 3: The Fast mode I²C bus device can be used on a Standard-mode I²C bus system as long as the device satisfies the requirement of t_{SUDAT} ≥ 250 ns."
- 4: t_{CYCP} is the APB bus clock cycle time. For more information about the APB bus number to which the I²C is connected, see 8.Block Diagram in this data sheet.
To use fast mode plus (Fm+), set the peripheral bus clock at 64 MHz or more.
- 5: The noise filter time can be changed by register settings. Change the number of the noise filter steps according to the APB bus clock frequency.
- 6: When using fast mode plus (Fm+), set the I/O pin to the mode corresponding to I²C Fm+ in the EPFR register. See Chapter 12: I/O Port in FM4 Family Peripheral Manual Main Part (MN709-00001) for the details.

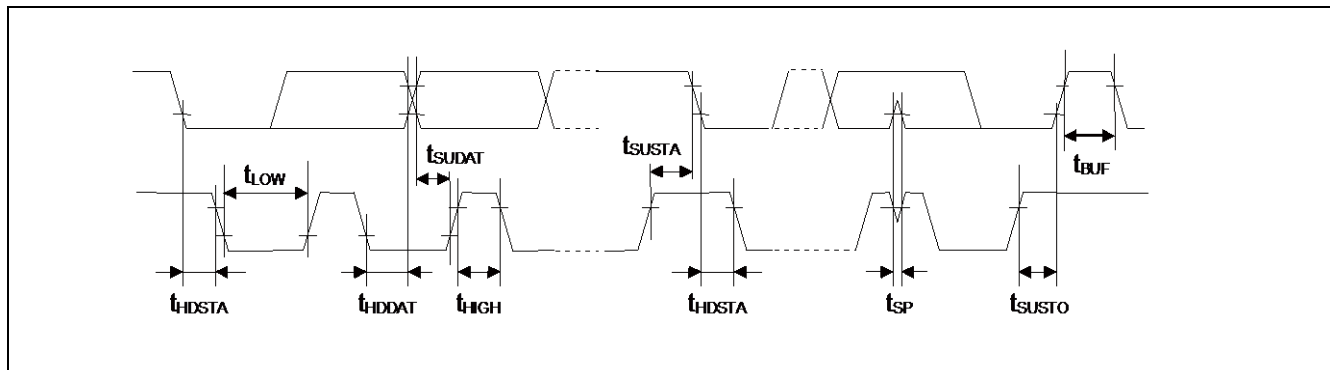

12.4.16 ETM/HTM Timing

 ($V_{CC} = 2.7V$ to $5.5V$, $V_{SS} = 0V$)

| Parameter | Symbol | Pin Name | Conditions | Value | | Unit | Remarks |
|----------------------|---------------|----------------------------|---------------------|-------|-----|------|---------|
| | | | | Min | Max | | |
| Data hold | t_{ETMH} | TRACECLK, TRACED[15: 0] | $V_{CC} \geq 4.5 V$ | 2 | 9 | ns | |
| | | | $V_{CC} < 4.5 V$ | 2 | 15 | | |
| TRACECLK frequency | $1/t_{TRACE}$ | TRACECLK | $V_{CC} \geq 4.5 V$ | | 50 | MHz | |
| | | | $V_{CC} < 4.5 V$ | | 32 | | |
| TRACECLK clock cycle | t_{TRACE} | | $V_{CC} \geq 4.5 V$ | 20 | - | ns | |
| | | | $V_{CC} < 4.5 V$ | 31.25 | - | | |

Note:

- When the external load capacitance $C_L = 30 pF$.

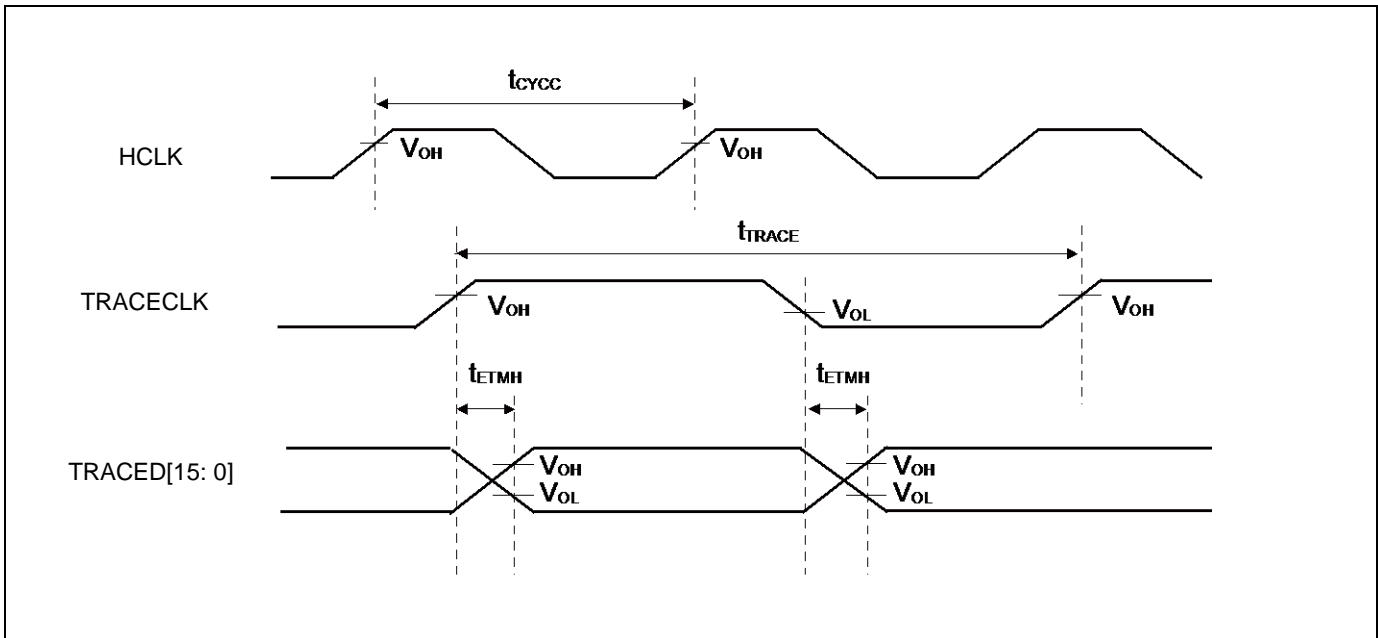

12.4.17 JTAG Timing

 ($V_{CC} = 2.7V$ to $5.5V$, $V_{SS} = 0V$)

| Parameter | Symbol | Pin Name | Conditions | Value | | Unit | Remarks |
|---------------------|-------------|------------------|---------------------|-------|-----|------|---------|
| | | | | Min | Max | | |
| TMS, TDI setup time | t_{JTAGS} | TCK, TMS, TDI | $V_{CC} \geq 4.5 V$ | 15 | - | ns | |
| | | | $V_{CC} < 4.5 V$ | | | | |
| TMS, TDI hold time | t_{JTAGH} | TCK, TMS, TDI | $V_{CC} \geq 4.5 V$ | 15 | - | ns | |
| | | | $V_{CC} < 4.5 V$ | | | | |
| TDO delay time | t_{JTAGD} | TCK, TDO | $V_{CC} \geq 4.5 V$ | - | 25 | ns | |
| | | | $V_{CC} < 4.5 V$ | - | 45 | | |

Note:

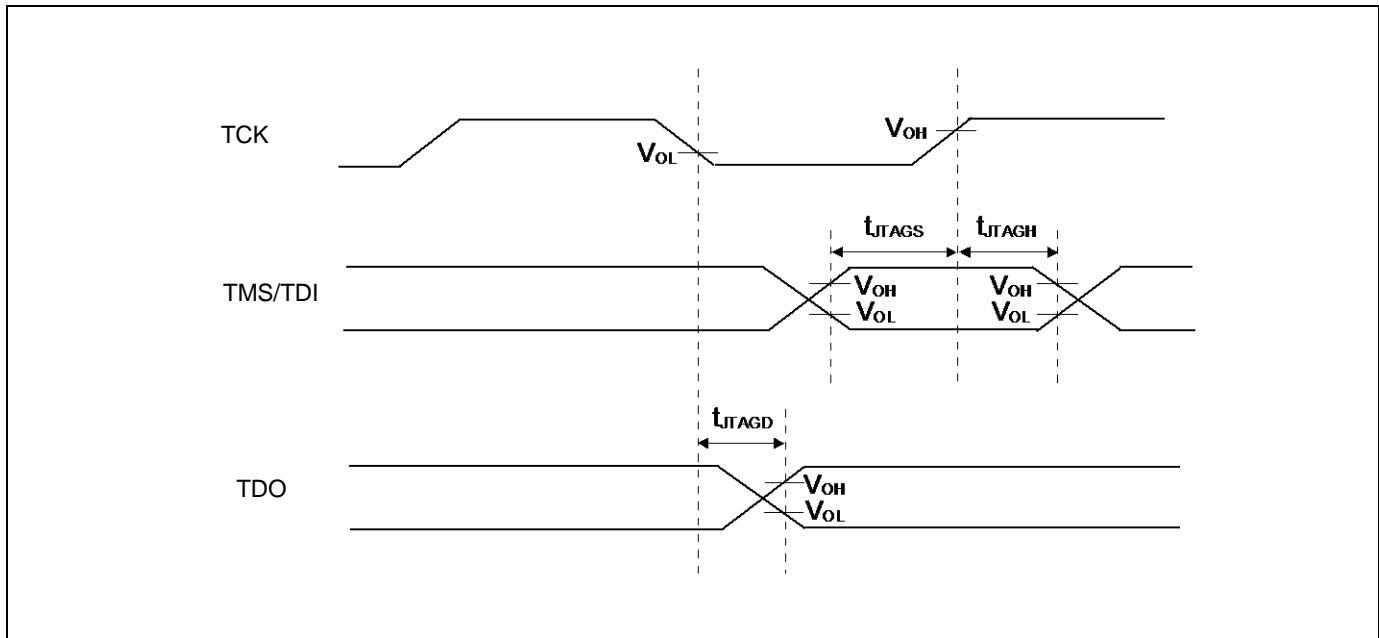
 - When the external load capacitance $C_L = 30 pF$.

12.4.18 Ethernet-MAC Timing

RMII Transmission (100 Mbps/10 Mbps)

(ETHV_{CC} = 3.0V to 3.6V, 4.5V to 5.5V^{*1}, V_{SS} = 0V, C_L = 25 pF)

| Parameter | Symbol | Pin Name | Conditions | Value | | Unit |
|---|----------------------|--|---|-------|-----|------|
| | | | | Min | Max | |
| Reference clock cycle time ^{*2} | t _{REFCYC} | E_RXCK_REFCK | 20 ns (typical) | - | - | ns |
| Reference clock High-pulse-width duty cycle | t _{REFCYCH} | E_RXCK_REFCK | t _{REFCYCH} /t _{REFCYC} | 35 | 65 | % |
| Reference clock Low-pulse-width duty cycle | t _{REFCYCL} | E_RXCK_REFCK | t _{REFCYCL} /t _{REFCYC} | 35 | 65 | % |
| Transmitted data → REFCK ↑ delay time | t _{RMIITX} | E_TX03, E_RX02, E_TX01, E_TX00, E_TXEN | - | - | 12 | ns |

- 1: When ETHV = 4.5 V to 5.5 V, it is recommended to add a series resistor at the output pin to suppress the output current.
- 2: The reference clock is fixed to 50 MHz in the RMII specifications. The clock accuracy should meet the PHY-device specifications.

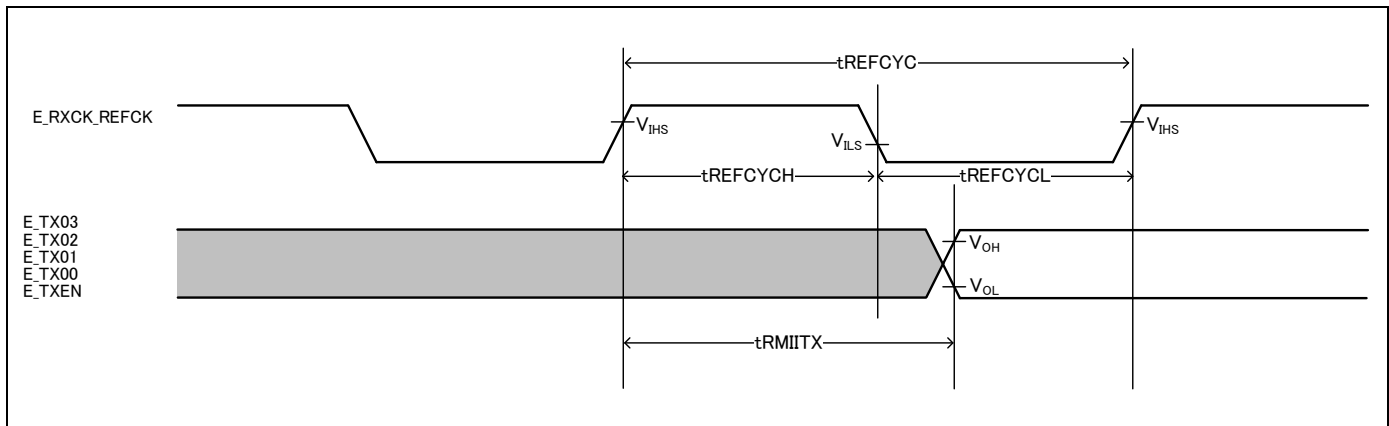

RMII Receiving (100 Mbps/10 Mbps)

(ETHV_{CC} = 3.0V to 3.6V, 4.5V to 5.5V, V_{SS} = 0V, C_L = 25 pF)

| Parameter | Symbol | Pin Name | Conditions | Value | | Unit |
|---|----------------------|--|---|-------|-----|------|
| | | | | Min | Max | |
| Reference clock cycle time* | t _{REFCYC} | E_RXCK_REFCK | 20 ns (typical) | - | - | ns |
| Reference clock High-pulse-width duty cycle | t _{REFCYCH} | E_RXCK_REFCK | t _{REFCYCH} /t _{REFCYC} | 35 | 65 | % |
| Reference clock Low-pulse-width duty cycle | t _{REFCYCL} | E_RXCK_REFCK | t _{REFCYCL} /t _{REFCYC} | 35 | 65 | % |
| Received data → REFCK ↑ Setup time | t _{RMIIRXS} | E_RX03, E_RX02, E_RX01, E_RX00, E_RXDV | - | 4 | - | ns |
| Received data → REFCK ↑ Hold time | t _{RMIIRXH} | E_RX03, E_RX02, E_RX01, E_RX00, E_RXDV | - | 2 | - | ns |

*: The reference clock is fixed to 50 MHz in the RMII specifications.
The clock accuracy should meet the PHY-device specifications.

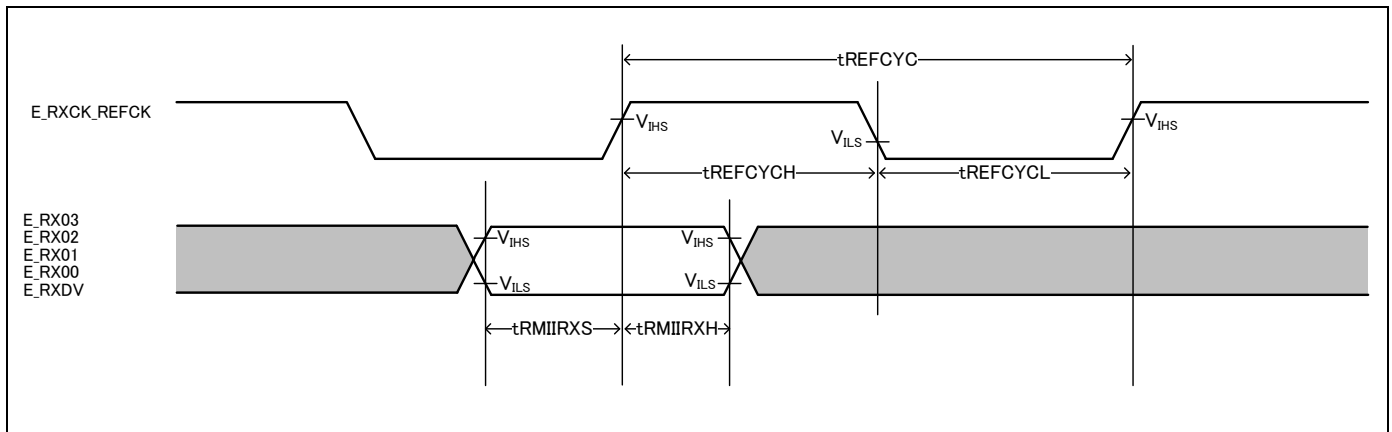

Management Interface

(ETHV_{CC} = 3.0V to 3.6V, 4.5V to 5.5V, V_{SS} = 0V, C_L = 25 pF)

| Parameter | Symbol | Pin Name | Conditions | Value | | Unit |
|--|---------------------|----------|--|-------|-----|------|
| | | | | Min | Max | |
| Management clock cycle time* | t _{MDCYCY} | E_MDC | - | 400 | - | ns |
| Management clock High pulse width duty cycle | t _{MDCYCH} | E_MDC | t _{MDCYCH} /t _{MDCYCY} | 35 | 65 | % |
| Management clock Low pulse width duty cycle | t _{MDCYCL} | E_MDC | t _{MDCYCL} /t _{MDCYCY} | 35 | 65 | % |
| MDC ↓ → MDIO Delay time | t _{MDO} | E_MDIO | - | - | 60 | ns |
| MDIO → MDC ↑ Setup time | t _{MDIS} | E_MDIO | - | 20 | - | ns |
| MDC ↑ → MDIO Hold time | t _{MDIH} | E_MDIO | - | 0 | - | ns |

*: The clock time should be set to a value greater than the minimum value by setting the Ethernet-MAC setting register.

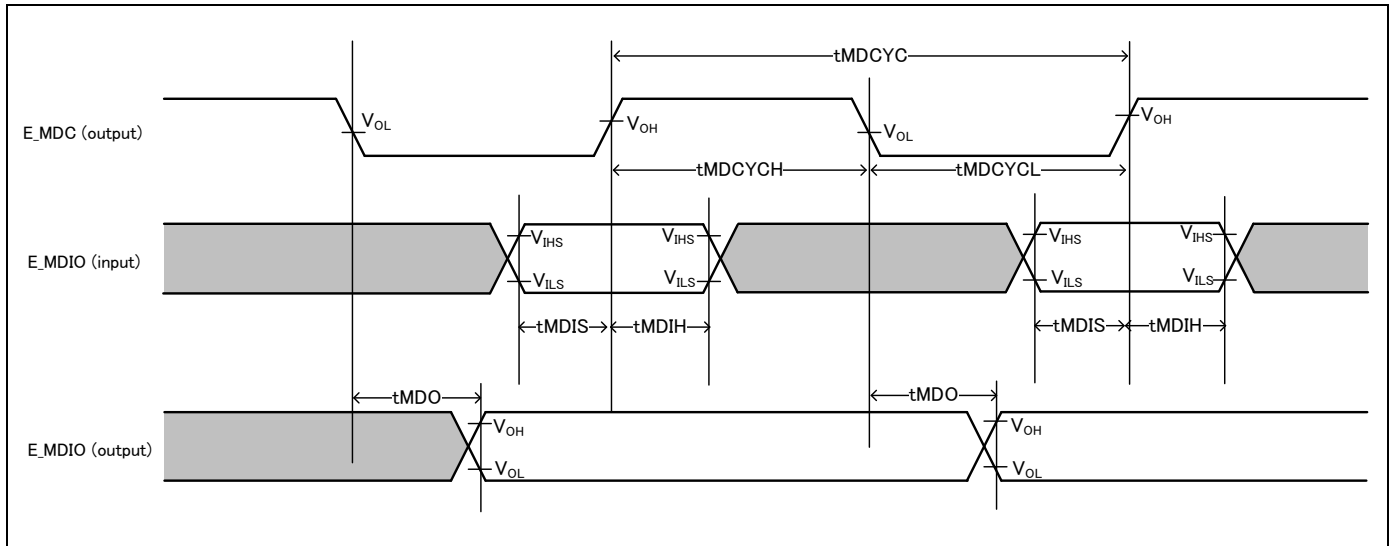

MII Transmission (100 Mbps/10 Mbps)

(ETHV_{CC} = 3.0V to 3.6V, 4.5V to 5.5V^{*1}; V_{SS} = 0V, C_L = 25 pF)

| Parameter | Symbol | Pin Name | Conditions | Value | | Unit |
|---|---------------------|--|---|-------|-----|------|
| | | | | Min | Max | |
| Transmission clock Cycle time*2 | t _{TXCYC} | E_TCK | 100 Mbps 40 ns (typical) | - | - | ns |
| | | | 100 Mbps 400 ns (typical) | - | - | ns |
| Transmission clock High-pulse-width duty cycle | t _{TXCYCH} | E_TCK | t _{TXCYCH} /t _{TXCYC} | 35 | 65 | % |
| Transmission clock Low-pulse-width duty cycle | t _{TXCYCL} | E_TCK | t _{TXCYCL} /t _{TXCYC} | 35 | 65 | % |
| TXCK ↑ → Transmitted data delay time | t _{MIITX} | E_TX03, E_TX02, E_TX01, E_TX00, E_TXEN | - | - | 24 | ns |

- 1: When ETHV = 4.5 V to 5.5 V, it is recommended to add a series resistor at the output pin to suppress the output current.
- 2: The transmission clock is fixed to 25 MHz or 2.5 MHz in the MII specifications. The clock accuracy should meet the PHY-device specifications.

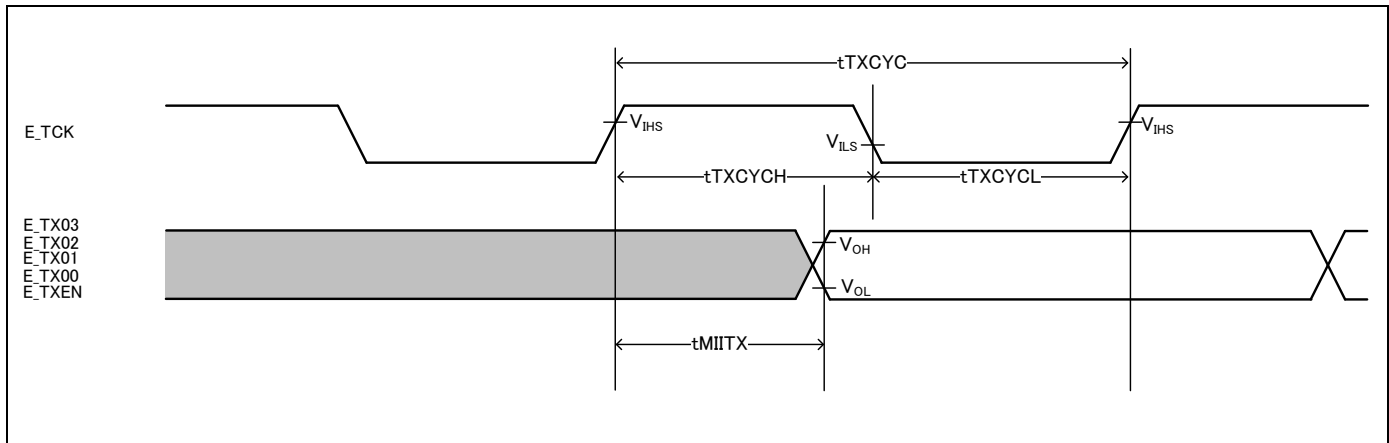

MII Receiving (100 Mbps/10 Mbps)

 (ETHV_{CC} = 3.0V to 3.6V, 4.5V to 5.5V, V_{SS} = 0V, C_L = 25 pF)

| Parameter | Symbol | Pin Name | Conditions | Value | | Unit |
|---|---------------------|--|---|-------|-----|------|
| | | | | Min | Max | |
| Receiving clock cycle time* | t _{RXCYC} | E_RXCK_REFCK | 100 Mbps 40 ns (typical) | - | - | ns |
| | | | 100 Mbps 400 ns (typical) | - | - | ns |
| Receiving clock High pulse width duty cycle | t _{RXCYCH} | E_RXCK_REFCK | t _{RXCYCH} /t _{RXCYC} | 35 | 65 | % |
| Receiving clock Low pulse width duty cycle | t _{RXCYCL} | E_RXCK_REFCK | t _{RXCYCL} /t _{RXCYC} | 35 | 65 | % |
| Received data → REFCK ↑ Setup time | t _{MIRXS} | E_RX03, E_RX02, E_RX01, E_RX00, E_RXDV | - | 5 | - | ns |
| REFCK ↑ → Received data Hold time | t _{MIRXH} | E_RX03, E_RX02, E_RX01, E_RX00, E_RXDV | - | 2 | - | ns |

*: The reference clock is fixed to 50 MHz in the RMII specifications.
 The clock accuracy should meet the PHY-device specifications.

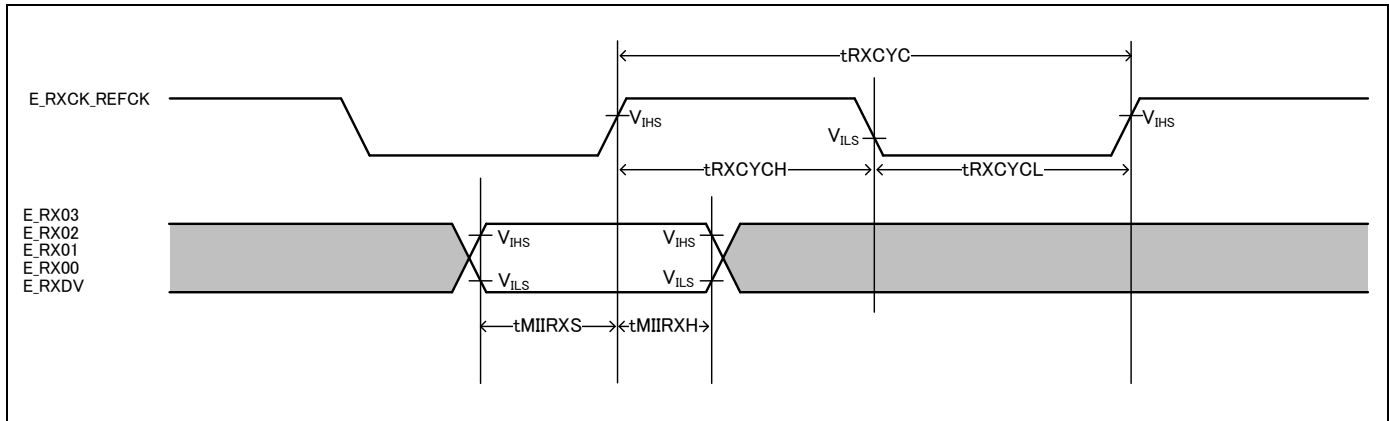

12.4.19 I²S Timing (Multi-function Serial Interface)

(V_{CC} = 2.7V to 5.5V, V_{SS} = 0V)

| Parameter | Symbol | Pin Name | Conditions | Value | | Unit | Remarks |
|----------------------------|--------------------|---------------------|------------|----------------------|-------|------|---------|
| | | | | Min | Max | | |
| I2SCK max frequency (*1) | f _{I2SCK} | MI2SCKx | - | - | 6.144 | MHz | |
| I2S clock cycle time (*1) | t _{ICYC} | MI2SCKx | - | 4 t _{CYCP2} | - | % | |
| I2S clock Duty cycle | Δ | MI2SCKx | | 45 | 55 | % | |
| I2SCK ↓ → I2SWS delay time | t _{SWDT} | MI2SCKx, MI2SWSx | - | -20 | +20 | ns | |
| I2SCK ↓ → I2SDO delay time | t _{SDDT} | MI2SCKx, MI2SDOx | - | -20 | +20 | ns | |
| I2SDI → I2SCK ↑ setup time | t _{DSST} | MI2SCKx, MI2SDIx | - | 36 | - | ns | |
| I2SCK ↑ → I2SDI hold time | t _{SDHT} | | - | 0 | - | ns | |
| I2SCK falling time | t _F | MI2SCKx | - | - | 5 | ns | |
| I2SCK rising time | t _R | | - | - | 5 | ns | |

*1: I2S clock should meet the multiple of PCLK (t_{ICYC}) and the frequency less than f_{I2SCK} meantime.

Notes:

- See Chapter 1-6: I²S (Inter-IC Sound bus) Interface in FM4 Family Peripheral Manual Communication Macro Part (MN709-00004) for the details.

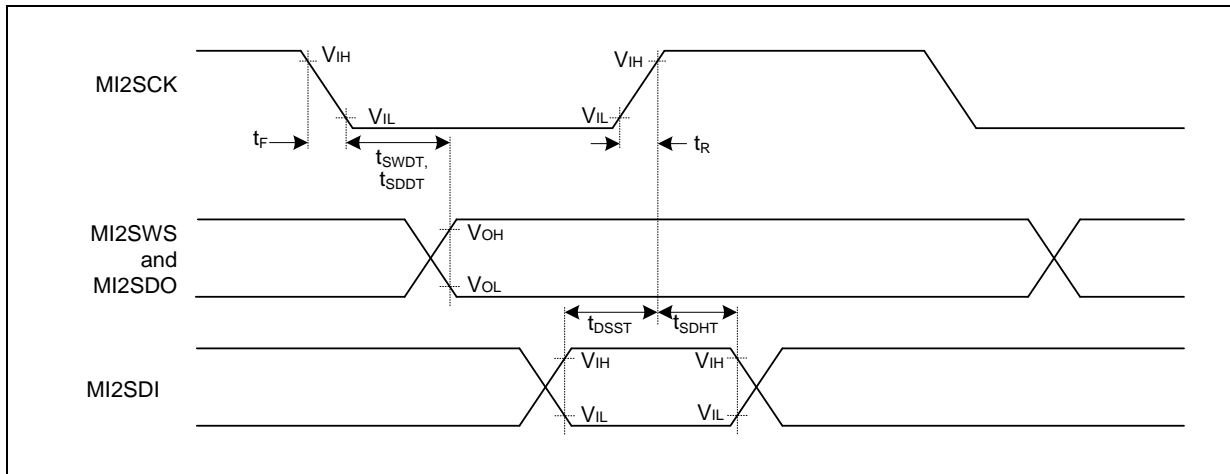

12.5 12-bit A/D Converter

Electrical Characteristics for the A/D Converter

($V_{CC} = AV_{CC} = 2.7V$ to $5.5V$, $V_{SS} = AV_{SS} = AV_{RL} = 0V$)

| Parameter | Symbol | Pin Name | Value | | | Unit | Remarks |
|---|-----------|----------|-----------------------|------|-----------------------|------|--------------------------------------|
| | | | Min | Typ | Max | | |
| Resolution | - | - | - | - | 12 | bit | |
| Integral nonlinearity | - | - | - 4.5 | - | + 4.5 | LSB | AVRH = 2.7 V to 5.5 V |
| Differential nonlinearity | - | - | - 2.5 | - | + 2.5 | LSB | |
| Zero transition voltage | V_{ZT} | ANxx | - 15 | - | + 15 | mV | |
| Full-scale transition voltage | V_{FST} | ANxx | AVRH - 15 | - | AVRH + 15 | mV | |
| | | | AV _{CC} - 15 | - | AV _{CC} + 15 | mV | |
| Conversion time | - | - | 0.5 ^{*1} | - | - | μs | AV _{CC} ≥ 4.5 V |
| Sampling time *2 | t_s | - | 0.15 | - | 10 | μs | AV _{CC} ≥ 4.5 V |
| | | | 0.3 | - | | | AV _{CC} < 4.5 V |
| Compare clock cycle *3 | t_{CCK} | - | 25 | - | 1000 | ns | AV _{CC} ≥ 4.5 V |
| | | | 50 | - | 1000 | | AV _{CC} < 4.5 V |
| State transition time to operation permission | t_{STT} | - | - | - | 1.0 | μs | |
| Power supply current (analog + digital) | - | AVCC | - | 0.69 | 0.92 | mA | A/D 1 unit operation |
| | | | - | 1.3 | 22 | μA | When A/D stop |
| Reference power supply current (AVRH) | - | AVRH | - | 1.1 | 1.97 | mA | A/D 1 unit operation AVRH = 5.5 V |
| | | | - | 0.3 | 6.3 | μA | When A/D stop |
| Analog input capacity | C_{AIN} | - | - | - | 12.05 | pF | |
| Analog input resistance | R_{AIN} | - | - | - | 1.2 | kΩ | AV _{CC} ≥ 4.5 V |
| | | | | | 1.8 | | AV _{CC} < 4.5 V |
| Interchannel disparity | - | - | - | - | 4 | LSB | |
| Analog port input leak current | - | ANxx | - | - | 5 | μA | |
| Analog input voltage | - | ANxx | AV _{SS} | - | AVRH | V | |
| | | | AV _{SS} | - | AV _{CC} | V | |
| Reference voltage | - | AVRH | 4.5 | - | AV _{CC} | V | T _{cck} < 50 ns |
| | | | 2.7 | - | AV _{CC} | | T _{cck} ≥ 50 ns |
| | | AVRL | AV _{SS} | - | AV _{SS} | V | |

1: The conversion time is the value of sampling time (t_s) + compare time (t_c).

The condition of the minimum conversion time is when the value of $T_s = 150$ ns and $T_c = 350$ ns ($AV_{CC} \geq 4.5V$). Ensure that it satisfies the value of sampling time (t_s) and compare clock cycle (t_{CCK}).

For setting of sampling time and compare clock cycle, see Chapter 1-1: A/D Converter in FM4 Family Peripheral Manual Analog Macro Part (MN709-00003). The register setting of the A/D converter is reflected by the APB bus clock timing. For more information about the APB bus number to which the A/D converter is connected, see 8. Block Diagram in this data sheet.

The sampling clock and compare clock are set at base clock (HCLK).

2: A necessary sampling time changes by external impedance. Ensure that it sets the sampling time to satisfy (Equation 1).

3: The compare time (t_c) is the value of (Equation 2).

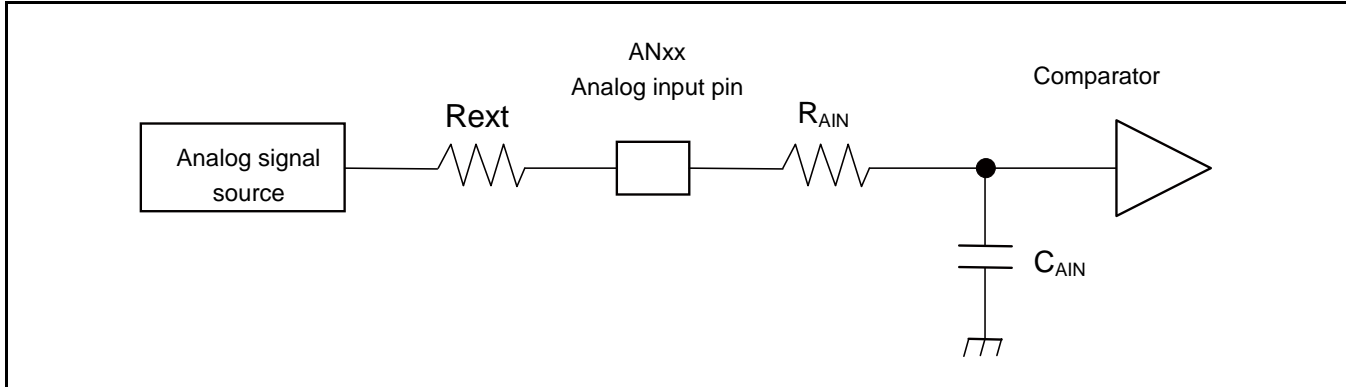

(Equation 1) $t_S \geq (R_{AIN} + R_{ext}) \times C_{AIN} \times 9$

t_S : Sampling time

R_{AIN} : Input resistance of A/D = 1.2 k Ω at 4.5 V $\leq AV_{CC} \leq$ 5.5 V

Input resistance of A/D = 1.8 k Ω at 2.7 V $\leq AV_{CC} <$ 4.5 V

C_{AIN} : Input capacity of A/D = 12.05 pF at 2.7 V $\leq AV_{CC} \leq$ 5.5 V

R_{ext} : Output impedance of external circuit

(Equation 2) $t_C = t_{CCK} \times 14$

t_C : Compare time

t_{CCK} : Compare clock cycle

Definition of 12-bit A/D Converter Terms

- Resolution: Analog variation that is recognized by an A/D converter.
- Integral nonlinearity: Deviation of the line between the zero-transition point (0b000000000000 ↔ 0b000000000001) and the full-scale transition point (0b111111111110 ↔ 0b111111111111) from the actual conversion characteristics.
- Differential nonlinearity: Deviation from the ideal value of the input voltage that is required to change the output code by 1 LSB.

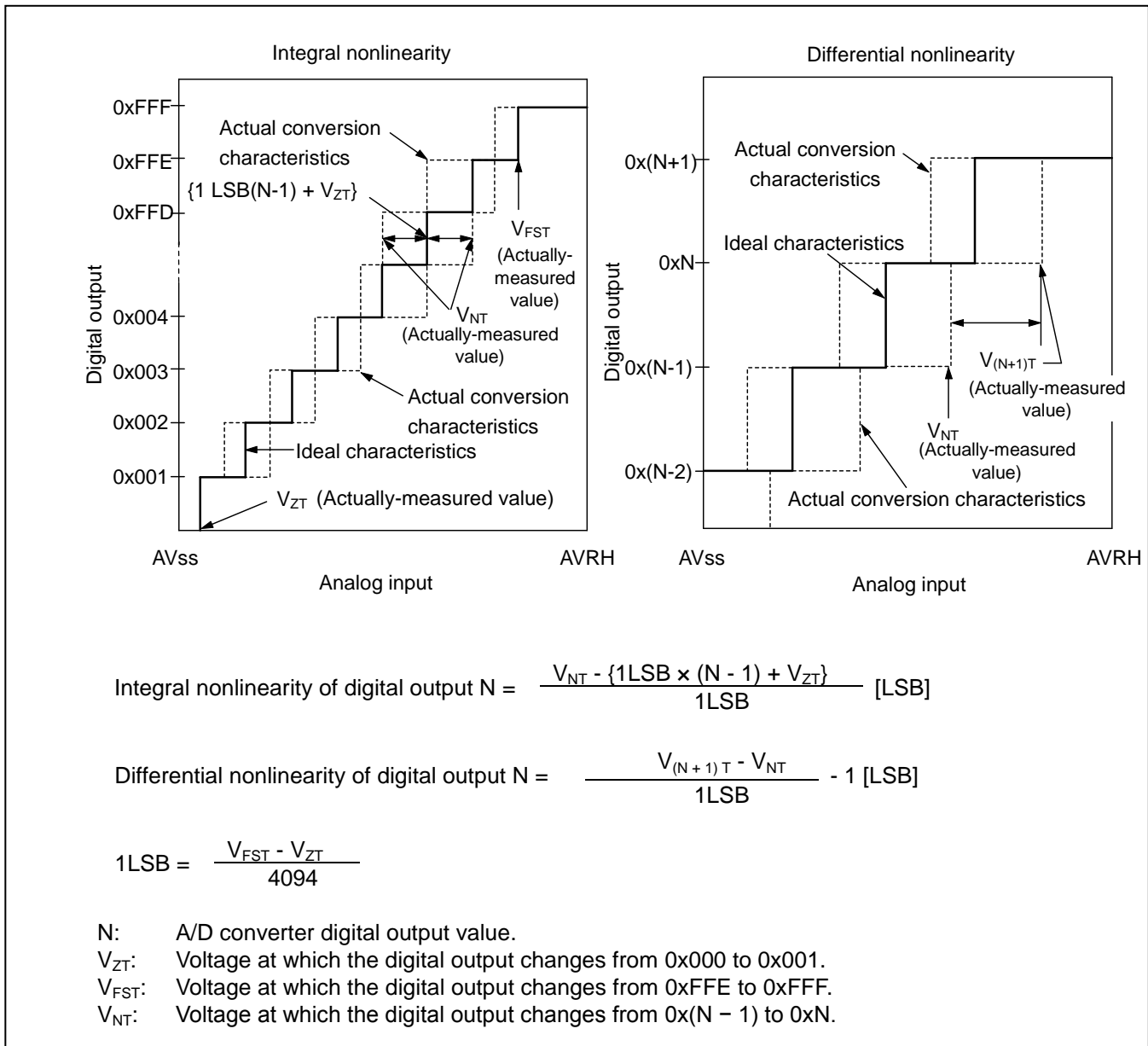

12.6 USB Characteristics

($V_{CC} = AV_{CC} = 2.7V$ to $5.5V$, $USBV_{CC0} = USBV_{CC1} = 3.0V$ to $3.6V$, $V_{SS} = AV_{SS} = 0V$)

| Parameter | Symbol | Pin Name | Conditions | Value | | Unit | Remarks |
|------------------------|--------------------------------|------------|---|----------------|-------------------|----------|---------|
| | | | | Min | Max | | |
| Input characteristics | Input H level voltage | V_{IH} | - | 2.0 | $USBV_{CC} + 0.3$ | V | *1 |
| | Input L level voltage | V_{IL} | - | $V_{SS} - 0.3$ | 0.8 | V | *1 |
| | Differential input sensitivity | V_{DI} | - | 0.2 | - | V | *2 |
| | Different common mode range | V_{CM} | - | 0.8 | 2.5 | V | *2 |
| Output characteristics | Output H level voltage | V_{OH} | External pull-down resistance = 15 k Ω | 2.8 | 3.6 | V | *3 |
| | Output L level voltage | V_{OL} | External pull-up resistance = 1.5 k Ω | 0.0 | 0.3 | V | *3 |
| | Crossover voltage | V_{CRS} | - | 1.3 | 2.0 | V | *4 |
| | Rise time | t_{FR} | Full-Speed | 4 | 20 | ns | *5 |
| | Fall time | t_{FF} | Full-Speed | 4 | 20 | ns | *5 |
| | Rise/fall time matching | t_{FRFM} | Full-Speed | 90 | 111.11 | % | *5 |
| | Output impedance | Z_{DRV} | Full-Speed | 28 | 44 | Ω | *6 |
| | Rise time | t_{LR} | Low-Speed | 75 | 300 | ns | *7 |
| | Fall time | t_{LF} | Low-Speed | 75 | 300 | ns | *7 |
| | Rise/fall time matching | t_{LRFM} | Low-Speed | 80 | 125 | % | *7 |

1: The switching threshold voltage of the single-end-receiver of USB I/O buffer is set as within V_{IL} (Max) = 0.8 V, V_{IH} (Min) = 2.0 V (TTL input standard).

There is some hysteresis applied to lower noise sensitivity.

2: Use differential-receiver to receive USB differential data signal. Differential-receiver has 200 mV of differential input sensitivity when the differential data input is within 0.8 V to 2.5 V to the local ground reference level.

Above voltage range is the common mode input voltage range.

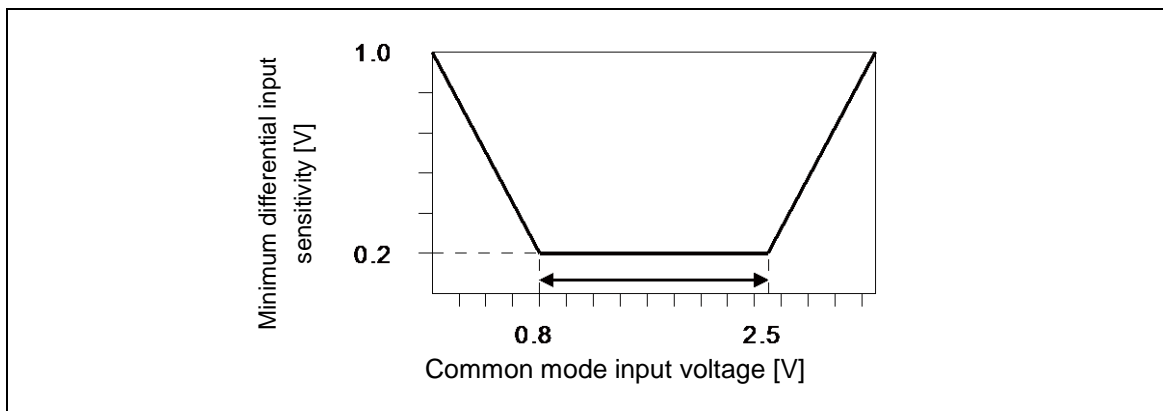

- 3: The output drive capability of the driver is below 0.3 V at low state (V_{OL}) (to 3.6 V and 1.5 k Ω load), and 2.8 V or above (to the VSS and 1.5 k Ω load) at high state (V_{OH}).
- 4: The cross voltage of the external differential output signal (D +/D -) of USB I/O buffer is within 1.3 V to 2.0 V.

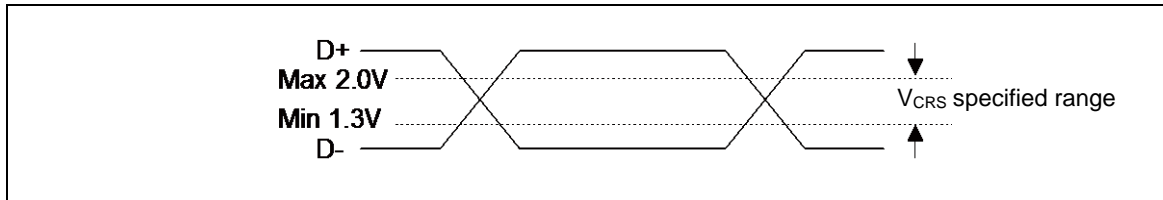

- 5: They indicate rise time (t_{RISE}) and fall time (t_{FALL}) of the full-speed differential data signal. They are defined by the time between 10% and 90% of the output signal voltage. For full-speed buffer, t_r/t_f ratio is regulated as within $\pm 10\%$ to minimize RFI emission.

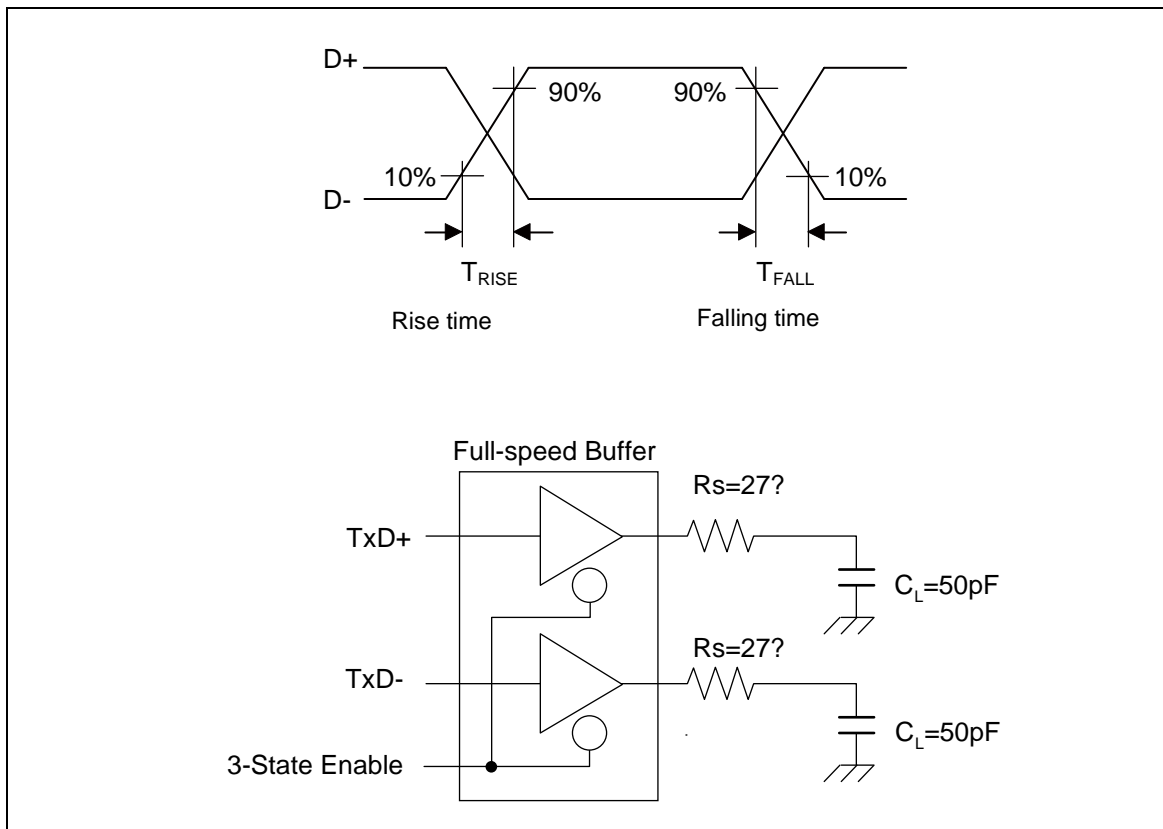

6: USB Full-speed connection is performed via twisted-pair cable shield with $90\Omega \pm 15\%$ characteristic impedance (differential mode).

USB standard defines that the output impedance of the USB driver must be in the range from 28Ω to 44Ω . So, a discrete series resistor (R_s) addition is defined in order to satisfy the above definition and keep balance. When using this USB I/O, use it with 25Ω to 30Ω (recommended value 27Ω) series resistor R_s .

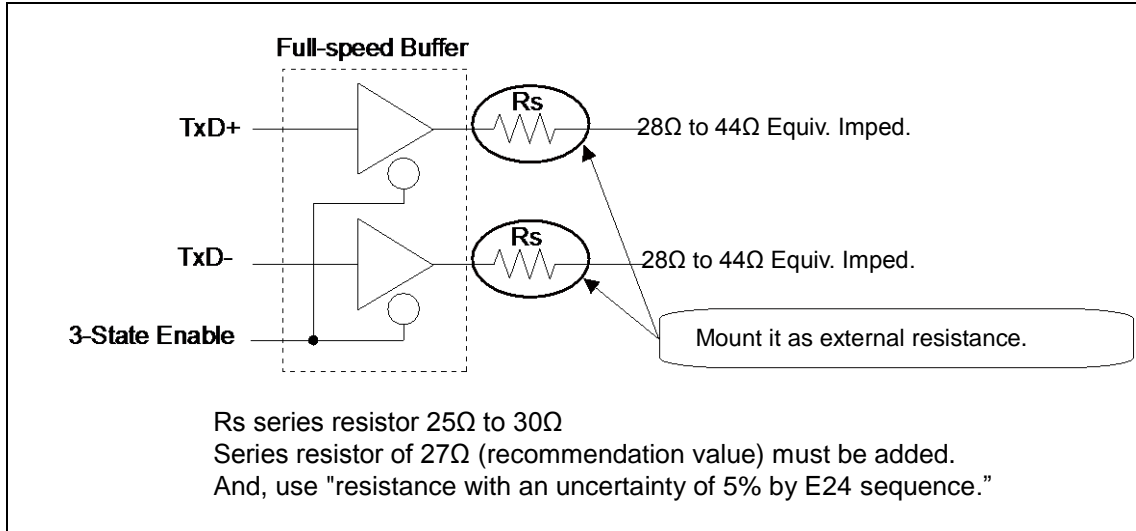

7: They indicate rise time (t_{RISE}) and fall time (t_{FALL}) of the low-speed differential data signal. They are defined by the time between 10% and 90% of the output signal voltage.

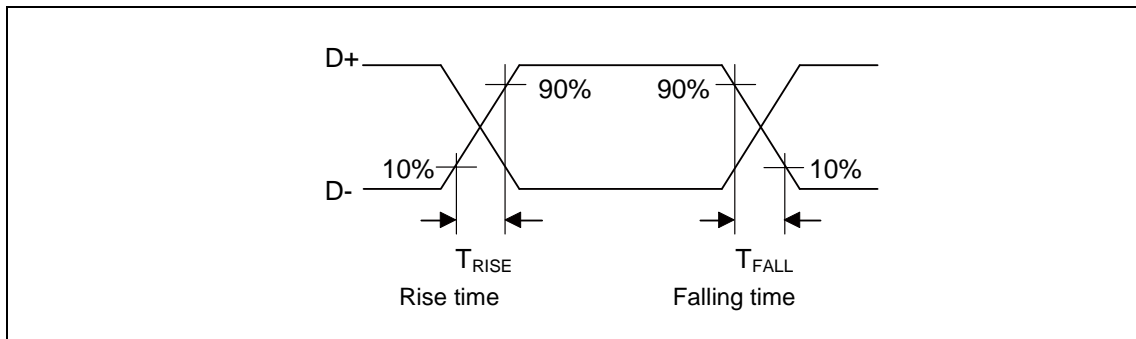

Note:

- See Low-Speed Load (Compliance Load) for conditions of external load.

Low-Speed Load (Upstream Port Load) - Reference 1

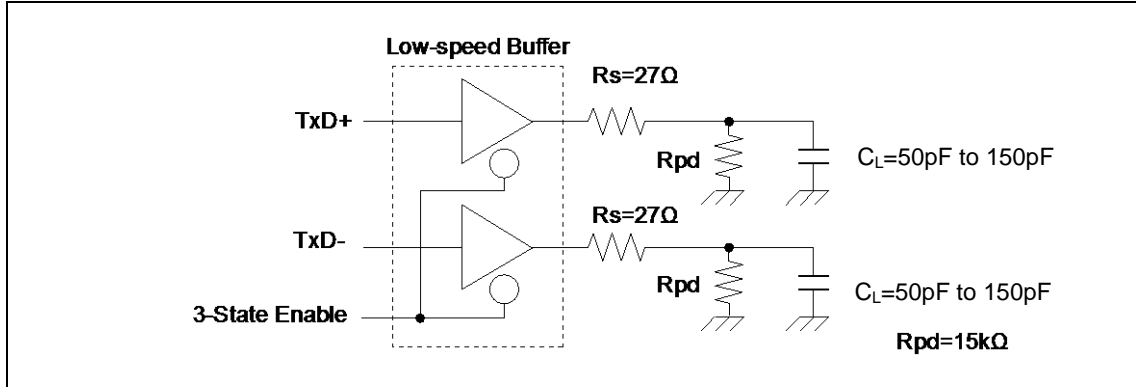

Low-Speed Load (Downstream Port Load) - Reference 2

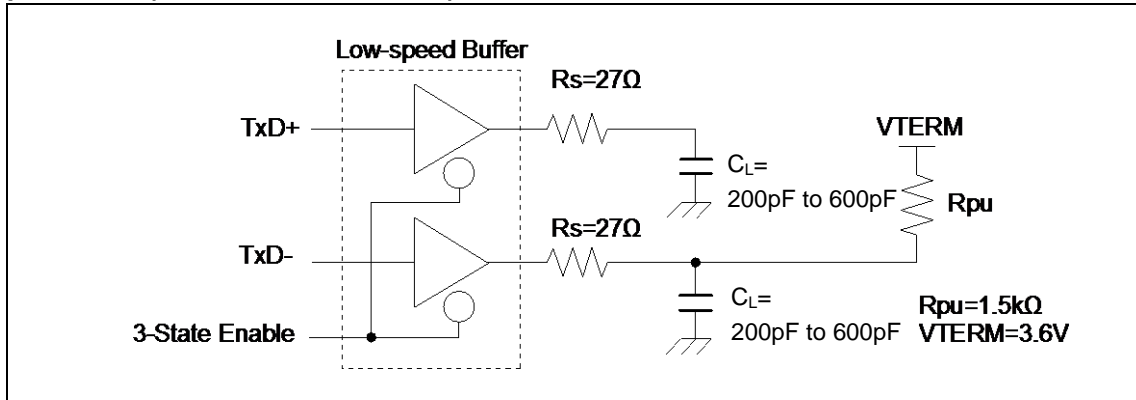

Low-Speed Load (Compliance Load)

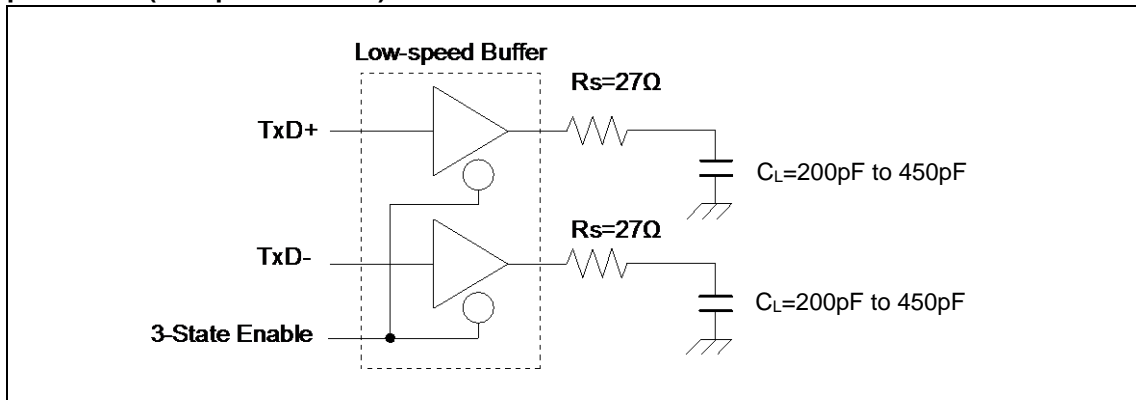

12.7 Low-Voltage Detection Characteristics

12.7.1 Low-Voltage Detection Reset

| Parameter | Symbol | Conditions | Value | | | Unit | Remarks |
|------------------|--------|------------|-------|------|------|------|--------------------|
| | | | Min | Typ | Max | | |
| Detected voltage | VDL | - | 2.46 | 2.55 | 2.64 | V | When voltage drops |
| Released voltage | VDH | - | 2.51 | 2.60 | 2.69 | V | When voltage rises |

12.7.2 Interrupt of Low-Voltage Detection

| Parameter | Symbol | Conditions | Value | | | Unit | Remarks |
|-----------------------------|-------------------|--------------|-------|------|--------------------------|------|--------------------|
| | | | Min | Typ | Max | | |
| Detected voltage | VDL | SVHI = 00111 | 2.80 | 2.90 | 3.00 | V | When voltage drops |
| Released voltage | VDH | | 2.90 | 3.00 | 3.11 | V | When voltage rises |
| Detected voltage | VDL | SVHI = 00100 | 2.99 | 3.10 | 3.21 | V | When voltage drops |
| Released voltage | VDH | | 3.09 | 3.20 | 3.31 | V | When voltage rises |
| Detected voltage | VDL | SVHI = 01100 | 3.18 | 3.30 | 3.42 | V | When voltage drops |
| Released voltage | VDH | | 3.28 | 3.40 | 3.52 | V | When voltage rises |
| Detected voltage | VDL | SVHI = 01111 | 3.67 | 3.80 | 3.93 | V | When voltage drops |
| Released voltage | VDH | | 3.76 | 3.90 | 4.04 | V | When voltage rises |
| Detected voltage | VDL | SVHI = 01110 | 3.76 | 3.90 | 4.04 | V | When voltage drops |
| Released voltage | VDH | | 3.86 | 4.00 | 4.14 | V | When voltage rises |
| Detected voltage | VDL | SVHI = 01001 | 4.05 | 4.20 | 4.35 | V | When voltage drops |
| Released voltage | VDH | | 4.15 | 4.30 | 4.45 | V | When voltage rises |
| Detected voltage | VDL | SVHI = 01000 | 4.15 | 4.30 | 4.45 | V | When voltage drops |
| Released voltage | VDH | | 4.25 | 4.40 | 4.55 | V | When voltage rises |
| Detected voltage | VDL | SVHI = 11000 | 4.25 | 4.40 | 4.55 | V | When voltage drops |
| Released voltage | VDH | | 4.34 | 4.50 | 4.66 | V | When voltage rises |
| LVD stabilization wait time | t _{LVDW} | - | - | - | 6000xt _{CYCP} * | µs | |

*: t_{CYCP} indicates the APB2 bus clock cycle time.

12.8 MainFlash Memory Write/Erase Characteristics

(V_{CC} = 2.7V to 5.5V)

| Parameter | | Value | | | Unit | Remarks |
|-------------------------------|--------------------------|-------|------|-----|------|---|
| | | Min | Typ | Max | | |
| Sector erase time | Large Sector | - | 0.7 | 3.7 | s | Includes write time prior to internal erase |
| | Small Sector | - | 0.3 | 1.1 | s | |
| Half word (16-bit) write time | Write cycles ≤ 100 times | - | 12 | 100 | μs | Not including system-level overhead time |
| | Write cycles > 100 times | | | 200 | | |
| Chip erase time* | | - | 13.6 | 68 | s | Includes write time prior to internal erase |

*: It indicates the chip erase time of 1MB MainFlash memory
 For devices with 1.5 MB or 2 MB of MainFlash memory, two erase cycles are required.
 See 3.2.2 Command Operating Explanations and 3.3.3 Flash Erase Operation in this product's Flash Programming Manual for the detail.

Write Cycles and Data Retention Time

| Erase/Write Cycles (Cycle) | Data Retention Time (Year) |
|----------------------------|----------------------------|
| 1,000 | 20* |
| 10,000 | 10* |
| 100,000 | 5* |

*: This value comes from the technology qualification (using Arrhenius equation to translate high temperature acceleration test result into average temperature value at + 85°C).

12.9 Standby Recovery Time

12.9.1 Recovery Cause: Interrupt/WKUP

The time from the interrupt occurring to the time of program operation start is shown.

Recovery Count Time

(V_{CC} = 2.7V to 5.5V, V_{SS} = 0V)

| Parameter | Symbol | Value | | Unit | Remarks |
|---|-------------------|--------|------|------|-----------------------|
| | | Typ | Max* | | |
| Sleep mode | t _{ICNT} | HCLKx1 | | μs | |
| High-speed CR Timer mode Main Timer mode PLL Timer mode | | 40 | 80 | μs | |
| Low-speed CR Timer mode | | 450 | 900 | μs | |
| Sub Timer mode | | 896 | 1136 | μs | |
| RTC mode Stop mode (High-speed CR/Main/PLL Run mode return) | | 316 | 581 | μs | |
| RTC mode Stop mode (Low-speed CR/sub Run mode return) | | 270 | 540 | μs | |
| Deep Standby RTC mode with RAM retention | | 365 | 667 | μs | without RAM retention |
| Deep Standby Stop mode with RAM retention | | 365 | 667 | μs | with RAM retention |

*: The maximum value depends on the built-in CR accuracy.

Example of Standby Recovery Operation (when in External Interrupt Recovery*)

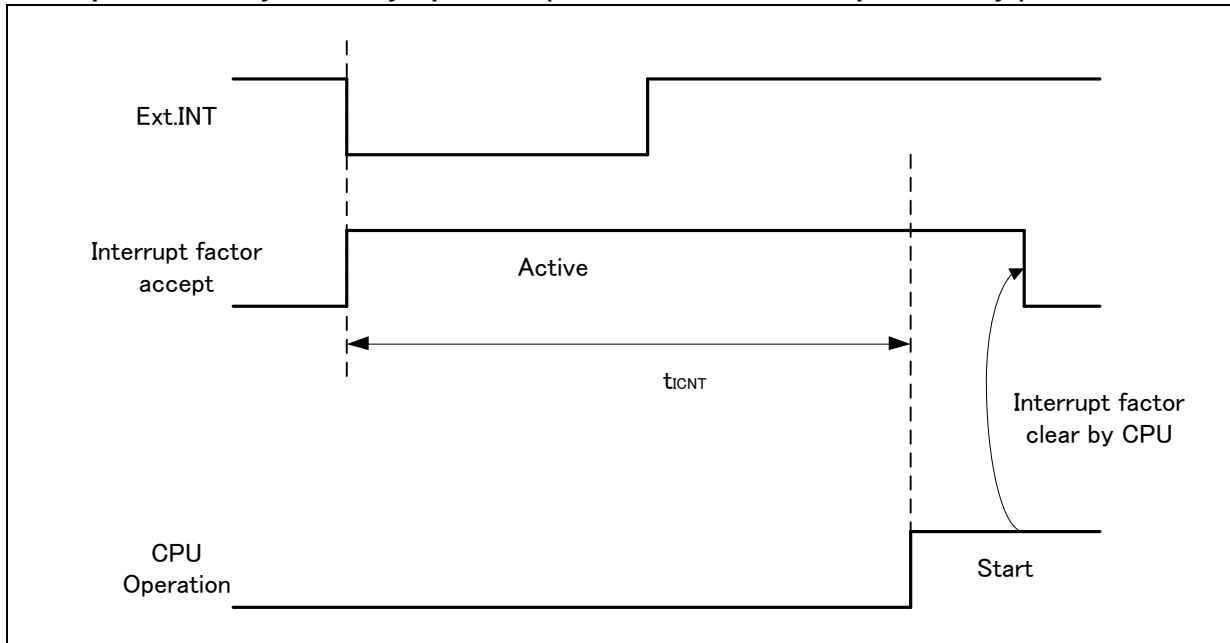

*: External interrupt is set to detecting fall edge.

Example of Standby Recovery Operation (when in Internal Resource Interrupt Recovery*)

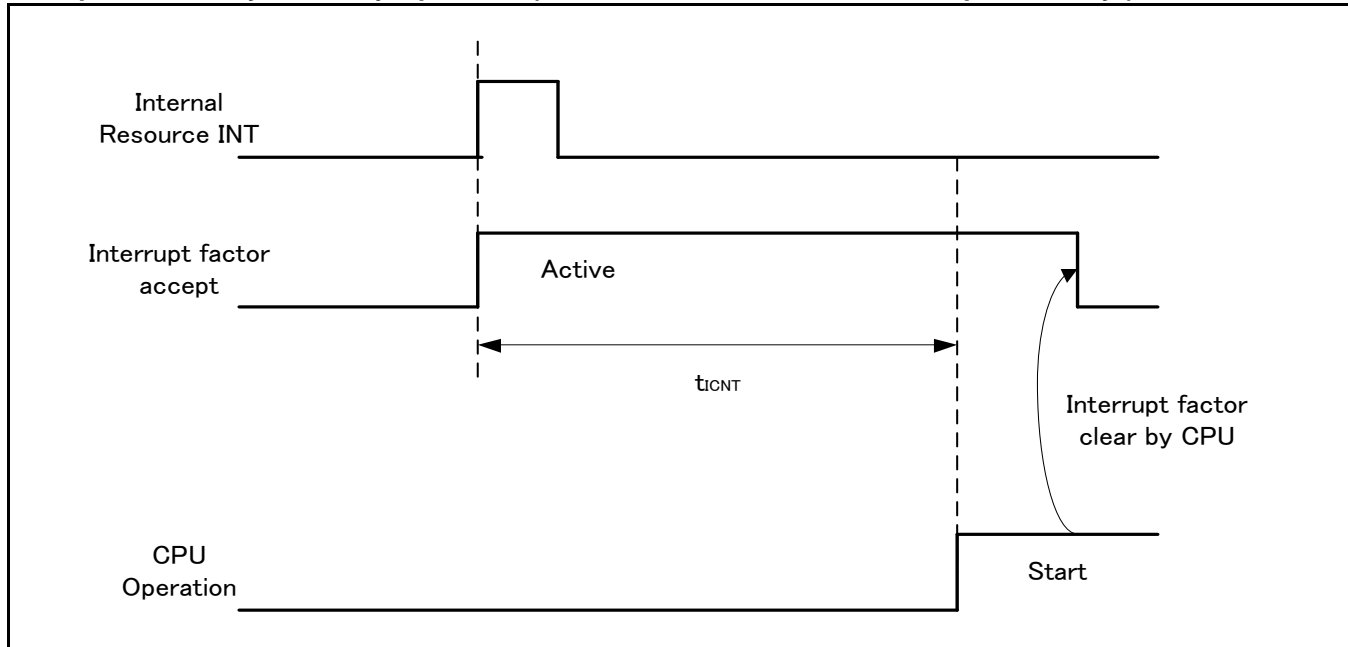

*: Depending on the standby mode, interrupt from the internal resource is not included in the recovery cause.

Notes:

- The return factor is different in each low-power consumption mode. See Chapter 6: Low Power Consumption mode and Operations of Standby modes in FM4 Family Peripheral Manual Main Part (MN709-00001).
- The recovery process is unique for each operating mode. See Chapter 6: Low Power Consumption mode in FM4 Family Peripheral Manual Main Part (MN709-00001).

12.9.2 Recovery Cause: Reset

The time from reset release to the program operation start is shown.

Recovery Count Time

($V_{CC} = 2.7V$ to $5.5V$, $V_{SS} = 0V$)

| Parameter | Symbol | Value | | Unit | Remarks |
|---|-------------------|-------|------|------|-----------------------|
| | | Typ | Max* | | |
| Sleep mode | t _{RCNT} | 155 | 266 | μs | |
| High-speed CR Timer mode Main Timer mode PLL Timer mode | | 155 | 266 | μs | |
| Low-speed CR Timer mode | | 315 | 567 | μs | |
| Sub Timer mode | | 315 | 567 | μs | |
| RTC mode Stop mode | | 315 | 567 | μs | |
| Deep Standby RTC mode with RAM retention Deep Standby Stop mode with RAM retention | | 336 | 667 | μs | without RAM retention |
| | | 336 | 667 | μs | with RAM retention |

*: The maximum value depends on the built-in CR accuracy.

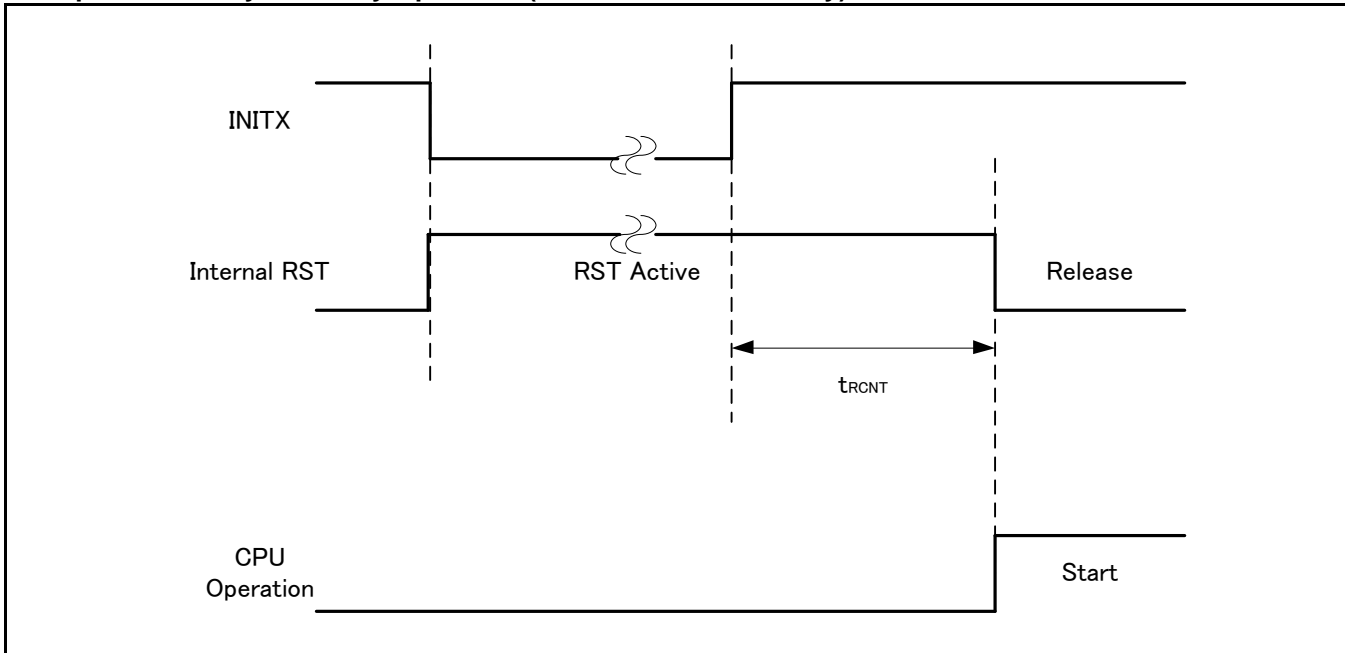
Example of Standby Recovery Operation (when in INITX Recovery)

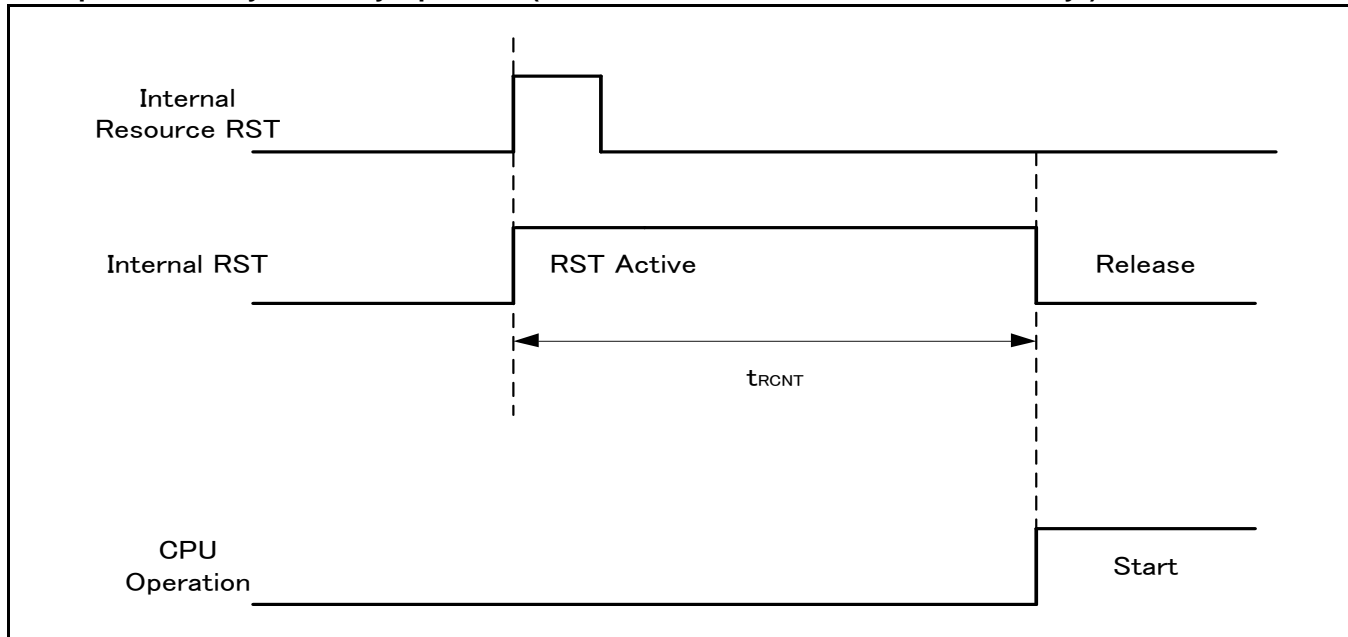
Example of Standby Recovery Operation (when in Internal Resource Reset Recovery*)

*: Depending on the low-power consumption mode, the reset issue from the internal resource is not included in the recovery cause.

Notes:

- The return factor is different in each low power consumption mode. See Chapter 6: Low Power Consumption mode and Operations of Standby modes in "FM4 Family Peripheral Manual Main Part (MN709-00001).
- The recovery process is unique for each operating mode. See Chapter 6: Low Power Consumption mode in FM4 Family Peripheral Manual Main Part (MN709-00001).
- When the power-on reset/low-voltage detection reset, they are not included in the return factor. See 12.4.8 Power-On Reset Timing.
- In recovering from reset, CPU changes to High-speed Run mode. In the case of using the main clock and PLL clock, they need further main clock oscillation stabilization wait time and oscillation stabilization wait time of Main PLL clock.
- Internal resource reset indicates Watchdog reset and CSV reset.

13. Ordering Information

| Part Number | Flash | RAM | Crypto | Package |
|-------------------|--------|--------|--------|--|
| S6E2GK6H0AGV20000 | 512 KB | 128 KB | N/A | Plastic LQFP (0.5 mm pitch), 144 pin (FPT-144P-M08) |
| S6E2GK8H0AGV20000 | 1 MB | 192 KB | N/A | |
| S6E2GK6HHAGV20000 | 512 KB | 128 KB | Yes | |
| S6E2GK8HHAGV20000 | 1 MB | 192 KB | Yes | |
| S6E2GK6J0AGV20000 | 512 MB | 128 KB | N/A | Plastic LQFP (0.5 mm pitch), 176 pin (FPT-176P-M07) |
| S6E2GK8J0AGV20000 | 1 MB | 192 KB | N/A | |
| S6E2GK6JHAGV20000 | 512 MB | 128 KB | Yes | |
| S6E2GK8JHAGV20000 | 1 MB | 192 KB | Yes | |

14. Package Dimensions

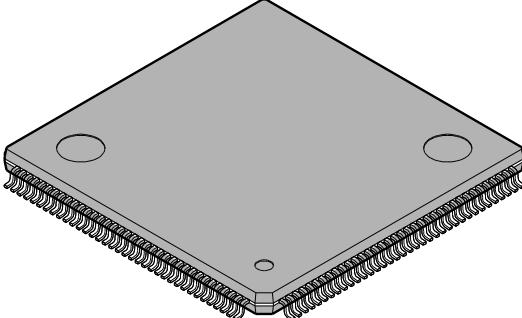
| | | |
|---|--------------------------------|-----------------------|
| <p style="text-align: center;">144-pin plastic LQFP</p>  <p style="text-align: center;">(FPT-144P-M08)</p> | Lead pitch | 0.50 mm |
| | Package width × package length | 20.0 × 20.0 mm |
| | Lead shape | Gullwing |
| | Sealing method | Plastic mold |
| | Mounting height | 1.70 mm MAX |
| | Weight | 1.20 g |
| | Code (Reference) | P-LFQFP144-20×20-0.50 |

144-pin plastic LQFP (FPT-144P-M08)

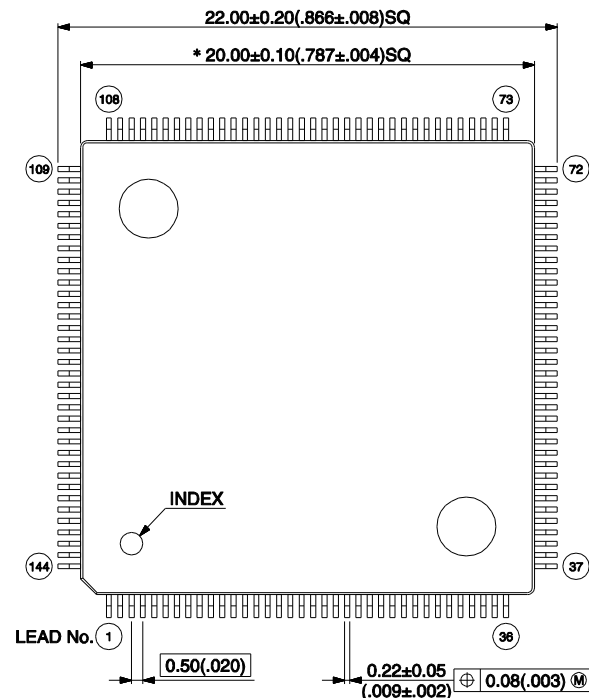

LEAD No. ①

0.50(.020)

0.22±0.05
(.009±.002) ⊕ 0.08(.003) M

**Note 1) *:Values do not include resin protrusion.
Resin protrusion is +0.25(.010)Max(each side).**

Note 2) Pins width and pins thickness include plating thickness.

Note 3) Pins width do not include tie bar cutting remainder.

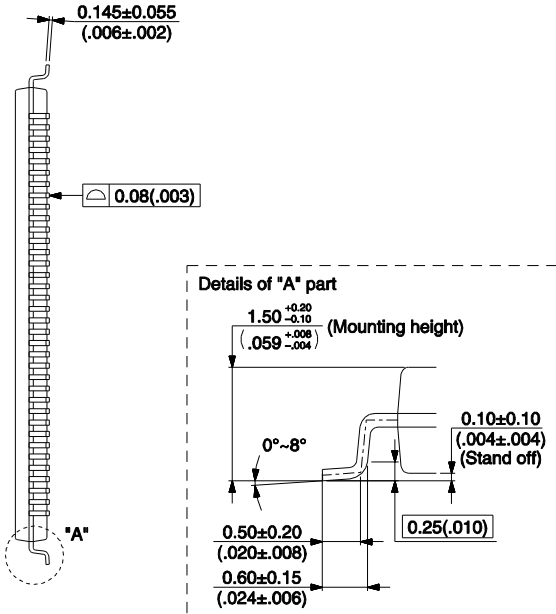

Details of "A" part

1.50^{+0.20}/_{-0.10} (Mounting height)
(.059^{+0.008}/_{-0.004})

0°~8°

0.10±0.10 (.004±.004) (Stand off)

0.50±0.20 (.020±.008)

0.60±0.15 (.024±.006)

0.25(.010)

© 2003-2010 FUJITSU SEMICONDUCTOR LIMITED F144019S-c-4-8

Dimensions in mm (inches).
Note: The values in parentheses are reference values.

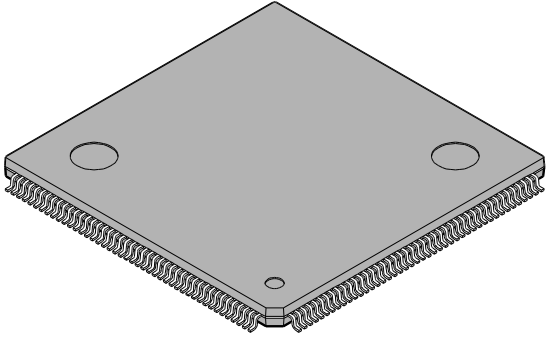
| | | |
|---|--------------------------------|-----------------------|
| <p>176-pin plastic LQFP</p>  <p>(FPT-176P-M07)</p> | Lead pitch | 0.50 mm |
| | Package width × package length | 24.0 × 24.0 mm |
| | Lead shape | Gullwing |
| | Sealing method | Plastic mold |
| | Mounting height | 1.70 mm MAX |
| | Code (Reference) | P-LQFP-0176-2424-0.50 |
| | | |

176-pin plastic LQFP (FPT-176P-M07)

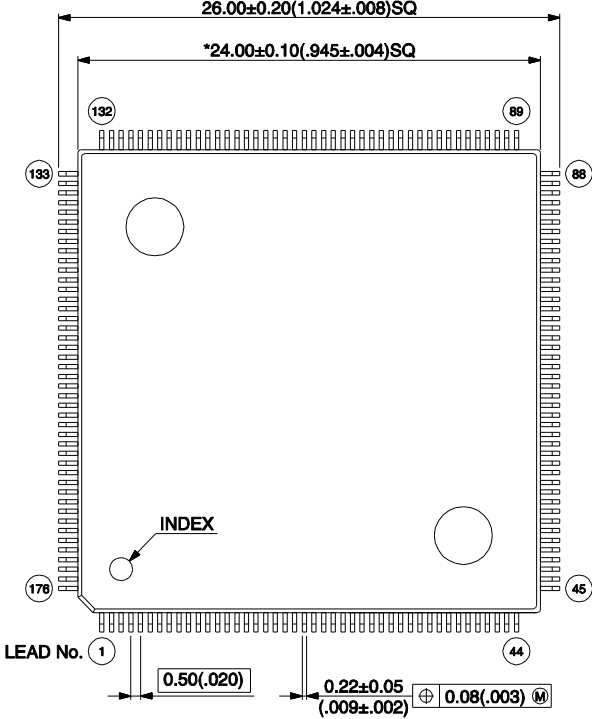

LEAD No. 1

INDEX

0.50(.020)

0.22±0.05 (.009±.002) ⊕ 0.08(.003) M

Note 1) * : Values do not include resin protrusion.
Resin protrusion is +0.25(.010)Max(each side).

Note 2) Pins width and pins thickness include plating thickness

Note 3) Pins width do not include tie bar cutting remainder.

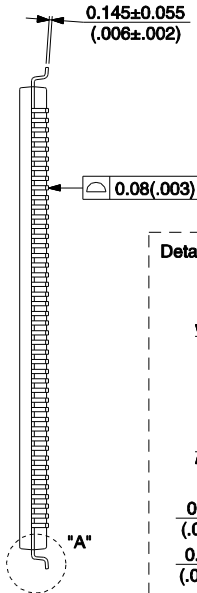

Details of "A" part

1.50^{+0.20}_{-0.10} (.059^{+0.008}_{-0.004}) (Mounting height)

0°~8°

0.10±0.10 (.004±.004) (Stand off)

0.50±0.20 (.020±.008)

0.60±0.15 (.024±.006)

0.25(.010)

© 2004-2010 FUJITSU SEMICONDUCTOR LIMITED F176013S-c-1-3

Dimensions in mm (inches).
Note: The values in parentheses are reference values.

Document History

Document Title: S6E2G26H0A, S6E2G28H0A, S6E2G26J0A, S6E2G28J0A, S6E2G26HHA, S6E2G28HHA, S6E2G26JHA, S6E2G28JHA 32-bit ARM® Cortex®-M4F FM4 Microcontroller

Document Number: 001-99446

| Revision | ECN | Orig. of Change | Submission Date | Description of Change |
|----------|---------|-----------------|-----------------|-----------------------|
| ** | 4861788 | YOHO | 08/11/2015 | New Spec. |

Sales, Solutions, and Legal Information

Worldwide Sales and Design Support

Cypress maintains a worldwide network of offices, solution centers, manufacturer's representatives, and distributors. To find the office closest to you, visit us at [Cypress Locations](#).

Products

| | |
|--|---|
| Automotive | cypress.com/go/automotive |
| Clocks & Buffers | cypress.com/go/clocks |
| Interface | cypress.com/go/interface |
| Lighting & Power Control | cypress.com/go/powerpsoc |
| Memory | cypress.com/go/memory |
| PSoC | cypress.com/go/psoc |
| Touch Sensing | cypress.com/go/touch |
| USB Controllers | cypress.com/go/USB |
| Wireless/RF | cypress.com/go/wireless |
| Spansion Products | spansion.com/Products |

PSoC® Solutions

[psoc.cypress.com/solutions](#)

[PSoC 1](#) | [PSoC 3](#) | [PSoC 4](#) | [PSoC 5LP](#)

Cypress Developer Community

[Community](#) | [Forums](#) | [Blogs](#) | [Video](#) | [Training](#)

Technical Support

[cypress.com/go/support](#)

Cypress, the Cypress logo, Spansion®, the Spansion logo, MirrorBit®, MirrorBit® Eclipse™, ORNAND™, Easy DesignSim™, Traveo™ and combinations thereof, are trademarks and registered trademarks of Cypress Semiconductor Corp. ARM and Cortex are the registered trademarks of ARM Limited in the EU and other countries. All other trademarks or registered trademarks referenced herein are the property of their respective owners.

© Cypress Semiconductor Corporation, 2015. The information contained herein is subject to change without notice. Cypress Semiconductor Corporation assumes no responsibility for the use of any circuitry other than circuitry embodied in a Cypress product. Nor does it convey or imply any license under patent or other rights. Cypress products are not warranted nor intended to be used for medical, life support, life saving, critical control or safety applications, unless pursuant to an express written agreement with Cypress. Furthermore, Cypress does not authorize its products for use as critical components in life-support systems where a malfunction or failure may reasonably be expected to result in significant injury to the user. The inclusion of Cypress products in life-support systems application implies that the manufacturer assumes all risk of such use and in doing so indemnifies Cypress against all charges.

This Source Code (software and/or firmware) is owned by Cypress Semiconductor Corporation (Cypress) and is protected by and subject to worldwide patent protection (United States and foreign), United States copyright laws and international treaty provisions. Cypress hereby grants to licensee a personal, non-exclusive, non-transferable license to copy, use, modify, create derivative works of, and compile the Cypress Source Code and derivative works for the sole purpose of creating custom software and or firmware in support of licensee product to be used only in conjunction with a Cypress integrated circuit as specified in the applicable agreement. Any reproduction, modification, translation, compilation, or representation of this Source Code except as specified above is prohibited without the express written permission of Cypress.

Disclaimer: CYPRESS MAKES NO WARRANTY OF ANY KIND, EXPRESS OR IMPLIED, WITH REGARD TO THIS MATERIAL, INCLUDING, BUT NOT LIMITED TO, THE IMPLIED WARRANTIES OF MERCHANTABILITY AND FITNESS FOR A PARTICULAR PURPOSE. Cypress reserves the right to make changes without further notice to the materials described herein. Cypress does not assume any liability arising out of the application or use of any product or circuit described herein. Cypress does not authorize its products for use as critical components in life-support systems where a malfunction or failure may reasonably be expected to result in significant injury to the user. The inclusion of Cypress' product in a life-support systems application implies that the manufacturer assumes all risk of such use and in doing so indemnifies Cypress against all charges.

Use may be limited by and subject to the applicable Cypress software license agreement.