

FM4 S6E2C2 Series

32-bit ARM® Cortex®-M4F based Microcontroller
S6E2C28H0A/S6E2C29H0A/S6E2C2AH0A/
S6E2C28J0A/S6E2C29J0A/S6E2C2AJ0A/
S6E2C28L0A/S6E2C29L0A/S6E2C2AL0A



Data Sheet (Preliminary)

Notice to Readers: This document states the current technical specifications regarding the Spansion product(s) described herein. The Preliminary status of this document indicates that product qualification has been completed, and that initial production has begun. Due to the phases of the manufacturing process that require maintaining efficiency and quality, this document may be revised by subsequent versions or modifications due to changes in technical specifications.

Notice On Data Sheet Designations

SpanSion Inc. issues data sheets with advance information or preliminary designations to advise readers of product information or intended specifications throughout the product life cycle, including development, qualification, initial production, and full production. In all cases, however, readers are encouraged to verify that they have the latest information before finalizing their design. The following descriptions of SpanSion data sheet designations are presented here to highlight their presence and definitions.

Advance Information

The Advance Information designation indicates that SpanSion Inc. is developing one or more specific products, but has not committed any design to production. Information presented in a document with this designation is likely to change, and in some cases, development on the product may discontinue. SpanSion Inc. therefore places the following conditions upon Advance Information content:

“This document contains information on one or more products under development at SpanSion Inc. The information is intended to help you evaluate this product. Do not design in this product without contacting the factory. SpanSion Inc. reserves the right to change or discontinue work on this proposed product without notice.”

Preliminary

The Preliminary designation indicates that the product development has progressed such that a commitment to production has taken place. This designation covers several aspects of the product life cycle, including product qualification, initial production, and the subsequent phases in the manufacturing process that occur before full production begins. Changes to the technical specifications presented in a Preliminary document should be expected while keeping these aspects of production under consideration. SpanSion places the following conditions upon Preliminary content:

“This document states the current technical specifications regarding the SpanSion product(s) described herein. The Preliminary status of this document indicates that product qualification has been completed and that initial production has begun. Due to the phases of the manufacturing process that require maintaining efficiency and quality, this document may be revised by subsequent versions or modifications to accommodate changes in technical specifications.”

Combination

Some data sheets contain a combination of products with different designations (Advance Information, Preliminary, or Full Production). This type of document distinguishes these products and their designations wherever necessary, typically on the first page, the ordering information page, and pages with the DC Characteristics table and the AC Erase and Program table (in the table notes). The disclaimer on the first page refers the reader to the notice on this page.

Full Production (No Designation on Document)

When a product has been in production for a period of time such that no changes or only nominal changes are expected, the Preliminary designation is removed from the data sheet. Nominal changes may include those affecting the number of ordering part numbers available, such as the addition or deletion of a speed option, temperature range, package type, or VIO range. Changes may also include those needed to clarify a description or to correct a typographical error or incorrect specification. SpanSion Inc. applies the following conditions to documents in this category:

“This document states the current technical specifications regarding the SpanSion product(s) described herein. SpanSion Inc. deems the products to have been in sufficient production volume such that subsequent versions of this document are not expected to change. However, typographical or specification corrections, or modifications to the valid combinations offered may occur.”

Questions regarding these document designations may be directed to your local sales office.

FM4 S6E2C2 Series



32-bit ARM® Cortex®-M4F based Microcontroller
S6E2C28H0A/S6E2C29H0A/S6E2C2AH0A/
S6E2C28J0A/S6E2C29J0A/S6E2C2AJ0A/
S6E2C28L0A/S6E2C29L0A/S6E2C2AL0A

Data Sheet (Preliminary)

1. Description

S6E2C2 Series is a family of highly integrated 32-bit microcontrollers dedicated for embedded controllers with high performance and competitive cost.

This series is based on the ARM Cortex-M4F processor with on-chip flash memory and SRAM, and has peripherals such as motor control timers, A/D converters, and communications interfaces (USB, CAN, UART, CSIO (SPI), I²C, LIN).

The products that are described in this data sheet are placed into TYPE3-M4 product categories "FM4 Family Peripheral Manual Main Part (MN709-00001)."

Note:

- *ARM and Cortex are the registered trademarks of ARM Limited in the EU and other countries.*



Publication Number S6E2C2_DS709-00013 Revision 0.1 Issue Date September 30, 2014

This document states the current technical specifications regarding the Spansion product(s) described herein. The Preliminary status of this document indicates that product qualification has been completed, and that initial production has begun. Due to the phases of the manufacturing process that require maintaining efficiency and quality, this document may be revised by subsequent versions or modifications due to changes in technical specifications.

Table of Contents

1. Description	3
2. Features	6
3. Product Lineup	14
4. Packages	16
5. Pin Assignments	17
6. Pin Descriptions	21
7. I/O Circuit Type	73
8. Handling Precautions	81
8.1. Precautions for Product Design	81
8.2. Precautions for Package Mounting	82
8.3. Precautions for Use Environment	84
9. Handling Devices	85
10. Block Diagram	88
11. Memory Size	89
12. Memory Map	89
13. Pin Status In Each CPU State	95
14. Electrical Characteristics	105
14.1. Absolute Maximum Ratings	105
14.2. Recommended Operating Conditions	107
14.3. DC Characteristics	112
14.3.1. Current Rating.....	112
14.3.2. Pin Characteristics	122
14.4. AC Characteristics.....	124
14.4.1. Main Clock Input Characteristics.....	124
14.4.2. Sub Clock Input Characteristics	125
14.4.3. Built-In CR Oscillation Characteristics	125
14.4.4. Operating Conditions of Main PLL (in the case of using main clock for input clock of PLL)	126
14.4.5. Operating Conditions of USB/Ethernet PLL · I ² S PLL (in the case of using main clock for input clock of PLL).....	126
14.4.6. Operating Conditions of Main PLL (in the case of using built-in high-speed CR clock for input clock of main PLL).....	127
14.4.7. Reset Input Characteristics.....	127
14.4.8. Power-On Reset Timing.....	128
14.4.9. GPIO Output Characteristics	128
14.4.10. External Bus Timing.....	129
14.4.11. Base Timer Input Timing.....	140
14.4.12. CSIO (SPI) Timing	141
14.4.13. External Input Timing	174
14.4.14. Quadrature Position/Revolution Counter Timing.....	175
14.4.15. I ² C Timing	177
14.4.16. SD Card Interface Timing	179
14.4.17. ETM/ HTM Timing.....	181
14.4.18. JTAG Timing.....	182
14.4.19. Ethernet-MAC Timing	183
14.4.20. I ² S Timing	188
14.4.21. High-Speed Quad SPI Timing.....	193
14.5. 12-bit A/D Converter	195
14.6. 12-bit D/A Converter	198
14.7. USB Characteristics	199
14.8. Low-Voltage Detection Characteristics	203

14.8.1. Low-Voltage Detection Reset	203
14.8.2. Interrupt of Low-Voltage Detection.....	203
14.9. MainFlash Memory Write/Erase Characteristics	204
14.10. Dual Flash Memory Write/Erase Characteristics.....	204
14.11. Standby Recovery Time.....	205
14.11.1. Recovery cause: Interrupt/WKUP	205
14.11.2. Recovery Cause: Reset	207
15. ORDERING INFORMATION	209
16. PACKAGE DIMENSIONS	210
17. Major Changes.....	214

2. Features

32-bit ARM Cortex-M4F Core

- Processor version: r0p1
- Up to 200 MHz frequency operation
- FPU built-in
- Support DSP instructions
- Memory protection unit (MPU): improves the reliability of an embedded system
- Integrated nested vectored interrupt controller (NVIC): 1 NMI (non-maskable interrupt) and 128 peripheral interrupts and 16 priority levels
- 24-bit system timer (Sys Tick): system timer for OS task management

On-chip Memories

- Flash memory

This series is based on two independent on-chip flash memories.

- Up to 2048 Kbytes
- Built-in flash accelerator system with 16 Kbytes trace buffer memory
- Read access to flash memory that can be achieved without wait-cycle up to an operating frequency of 72 MHz. Even at the operating frequency more than 72 MHz, an equivalent single cycle access to flash memory can be obtained by the flash accelerator system.
- Security function for code protection

- SRAM

This is composed of three independent SRAMs (SRAM0, SRAM1 and SRAM2). SRAM0 is connected to the I-code bus or D-code bus of Cortex-M4F core. SRAM1 and SRAM2 are connected to system bus of Cortex-M4F core.

- SRAM0: up to 192 Kbytes
- SRAM1: 32 Kbytes
- SRAM2: 32 Kbytes

External Bus Interface

- Supports SRAM, NOR, NAND flash and SDRAM device
- Up to 9 chip selects CS0 to CS8 (CS8 is only for SDRAM)
- 8/16/32-bit data width
- Up to 25-bit address bus
- Supports address/data multiplexing
- Supports external RDY function
- Supports scramble function
- Possible to set the validity/invalidity of the scramble function for the external areas 0x6000_0000 to 0xDFFF_FFFF in 4 Mbytes units.
- Possible to set two kinds of the scramble key

Note: It is necessary to use the Spansion provided software library to use the scramble function.

USB Interface (Max 2 Channels)

The USB interface is composed of a function and a host.

- USB function
 - USB 2.0 Full-speed supported
 - Max 6 EndPoint supported
 - EndPoint 0 is control transfer
 - EndPoint 1, 2 can be selected bulk-transfer, interrupt-transfer or isochronous-transfer
 - EndPoint 3 to 5 can select bulk-transfer or interrupt-transfer
 - EndPoint 1 to 5 comprise double buffer
 - The size of each endpoint is as follows.
 - Endpoint 0, 2 to 5: 64 byte
 - EndPoint 1: 256 byte
- USB host
 - USB2.0 Full-Speed/Low-Speed supported
 - Bulk-transfer, interrupt-transfer, and isochronous-transfer support
 - USB Device connected/dis-connected automatically detect
 - IN/OUT token handshake packet automatically
 - Max 256-byte packet length supported
 - Wake-up function supported

Multi-function Serial Interface (Max 16 channels)

- Separate 64 byte receive and transmit FIFO buffers for channels 0 to 7.
- Operation mode is selectable for each channel from the following:
 - UART
 - CSIO (SPI)
 - LIN
 - I²C
- UART
 - Full-duplex double buffer
 - Selection with or without parity supported
 - Built-in dedicated baud rate generator
 - External clock available as a serial clock
 - Various error detect functions available (parity errors, framing errors, and overrun errors)
- CSIO (SPI)
 - Full-duplex double buffer
 - Built-in dedicated baud rate generator
 - Overrun error detect function available
 - Serial chip select function (ch 6 and ch 7 only)
 - Supports high-speed SPI (ch 4 and ch 6 only)
 - Data length 5 to 16-bit
- LIN
 - LIN protocol Rev.2.1 supported
 - Full-duplex double buffer
 - Master/slave mode supported
 - LIN break field generation (can change to 13- to 16-bit length)
 - LIN break delimiter generation (can change to 1- to 4-bit length)
 - Various error detect functions available (parity errors, framing errors, and overrun errors)
- I²C
 - Standard mode (Max 100 kbps)/Fast mode (Max 400 kbps) supported
 - Fast mode Plus (Fm+) (Max 1000 kbps, only for ch 3 = ch A and ch 7 = ch B) supported

DMA Controller (8 channels)

DMA controller has an independent bus, so the CPU and DMA controller can process simultaneously.

- Eight independently configured and operated channels
- Transfer can be started by software or request from the built-in peripherals
- Transfer address area: 32-bit (4 GB)
- Transfer mode: Block transfer/Burst transfer/Demand transfer
- Transfer data type: bytes/half-word/word
- Transfer block count: 1 to 16
- Number of transfers: 1 to 65536

DSTC (Descriptor System data Transfer Controller; 256 Channels)

The DSTC can transfer data at high-speed without going via the CPU. The DSTC adopts the descriptor system and, following the specified contents of the descriptor that has already been constructed on the memory, can access directly the memory/peripheral device and perform the data-transfer operation.

It supports the software activation, the hardware activation, and the chain activation functions.

A/D Converter (Max 32 channels)

- 12-bit A/D Converter
 - Successive approximation type
 - Built-in three units
 - Conversion time: 0.5 μ s at 5V
 - Priority conversion available (priority at two levels)
 - Scanning conversion mode
 - Built-in FIFO for conversion data storage (for SCAN conversion: 16 steps, for priority conversion: 4 steps)

D/A Converter (Max 2 Channels)

- R-2R type
- 12-bit resolution

Base Timer (Max 16 Channels)

Operation mode is selected from the following for each channel:

- 16-bit PWM timer
- 16-bit PPG timer
- 16/32-bit reload timer
- 16/32-bit PWC timer

General Purpose I/O Port

This series can use its pins as general purpose I/O ports when they are not used for external bus or peripherals; moreover, the port relocate function is built in. It can set the I/O port to which the peripheral function can be allocated.

- Capable of pull-up control per pin
- Capable of reading pin level directly
- Built-in port-relocate function
- Up to 120 high-speed general-purpose I/O ports in 144 pin package
- Some pins 5V tolerant I/O.

See "6. Pin Descriptions" and "7. I/O Circuit Type" for the corresponding pins.

Multi-function Timer (Max 3 Units)

The multi-function timer is composed of the following blocks:

Minimum resolution: 5.00 ns

- 16-bit free-run timer × 3 ch/unit
- Input capture × 4 ch/unit
- Output compare × 6 ch/unit
- A/D activation compare × 6 ch/unit
- Waveform generator × 3 ch/unit
- 16-bit PPG timer × 3 ch/unit

The following functions can be used to achieve the motor control:

- PWM signal output function
- DC chopper waveform output function
- Dead time function
- Input capture function
- A/D convertor activate function
- DTIF (motor emergency stop) interrupt function

Real-Time Clock (RTC)

The real-time clock can count year, month, day, hour, minute, second, or day of the week from 01 to 99.

- Interrupt function with specifying date and time (year/month/day/hour/minute/second/day of the week) is available. This function is also available by specifying only year, month, day, hour, or minute.
- Timer interrupt function after set time or each set time.
- Capable of rewriting the time with continuing the time count.
- Leap year automatic count is available.

Quadrature Position/Revolution Counter (QPRC; Max 4 Channels)

The Quadrature Position/Revolution Counter (QPRC) is used to measure the position of the position encoder. It is also possible to use up/down counter.

- The detection edge of the three external event input pins AIN, BIN and ZIN is configurable.
- 16-bit position counter
- 16-bit revolution counter
- Two 16-bit compare registers

Dual Timer (32/16-bit Down Counter)

The dual timer consists of two programmable 32/16-bit down counters.

Operation mode is selectable from the following for each channel:

- Free-running
- Periodic (= Reload)
- One shot

Watch Counter

The watch counter is used for wake up from low-power consumption mode. It is possible to select the main clock, sub clock, built-in high-speed CR clock, or built-in low-speed CR clock as the clock source.

- Interval timer: up to 64 s (max) with a sub clock of 32.768 kHz

External Interrupt Controller Unit

- External interrupt input pin: Max 32 pins
- Include one non-maskable interrupt (NMI)

Watchdog Timer (2 Channels)

A watchdog timer can generate interrupts or a reset when a time-out value is reached.

This series consists of two different watchdogs: a "hardware" watchdog and a "software" watchdog.

The hardware watchdog timer is clocked by low-speed internal CR oscillator. The hardware watchdog is thus active in any power saving mode except RTC mode and Stop mode.

Cyclic Redundancy Check (CRC) Accelerator

The CRC accelerator helps to verify data transmission or storage integrity.

CCITT CRC16 and IEEE-802.3 CRC32 are supported.

- CCITT CRC16 generator polynomial: 0x1021
- IEEE-802.3 CRC32 generator polynomial: 0x04C11DB7

Programmable Cyclic Redundancy Check (PRGCRC) Accelerator

The CRC accelerator helps a verify data transmission or storage integrity.

CCITT CRC16, IEEE-802.3 CRC32 and generating polynomial are supported.

- CCITT CRC16 generator polynomial: 0x1021
- IEEE-802.3 CRC32 generator polynomial: 0x04C11DB7
- Generating polynomial

SD Card Interface

It is possible to use the SD card that conforms to the following standards.

- Part 1 Physical Layer Specification version 3.01
- Part E1 SDIO Specification version 3.00
- Part A2 SD Host Controller Standard Specification version 3.00
- 1-bit or 4-bit data bus

Ethernet-MAC

- Compliant with IEEE802.3 specification
- 10 Mbps/100 Mbps data transfer rates supported
- MII/RMII for external PHY device supported.
- MII: Max one channel
- RMII: Max one channel
- Full-duplex and half-duplex mode supported.
- Wake-ON-LAN supported
- Built-in dedicated descriptor-system DMAC
- Built-in 2 Kbytes transmit FIFO and 2 Kbytes receive FIFO.
- Compliant IEEE1588-2008 (PTP)

I²S (Inter-IC Sound Bus) Interface (TX x 1 channel, RX x 1 channel)

- Supports three transfer protocols
 - I²S
 - Left justified
 - DSP mode
 - Separate clock generation block for flexible system integration options
- Master/slave mode selectable
- RX Only, TX Only or TX and RX simultaneous operation selectable
- Word length is programmable from 7-bits to 32 bits
- RX/TX FIFO integrated (RX: 66 words x 32-bits, TX: 66 words x 32-bits)
- DMA, interrupts, or polling based data transfer supported

HDMI-CEC/Remote Control Receiver (Max 2 Channels)

- HDMI-CEC transmitter
 - Header block automatic transmission by judging signal free
 - Generating status interrupt by detecting arbitration lost
 - Generating START, EOM, ACK automatically to output CEC transmission by setting 1 byte data
 - Generating transmission status interrupt when transmitting 1 block (1 byte data and EOM/ACK)
- HDMI-CEC receiver
 - Automatic ACK reply function available
 - Line-error detection function available
- Remote control receiver
 - 4 bytes reception buffer
 - Repeat code detection function available

High-Speed Quad SPI

Up to 66 MHz clock rates for very fast data transfers to and from SPI compatible devices.
Up to 256 Mbytes of memory mapped address space.

- Single data rate (SDR)
- Supports single, dual, and quad data modes
- Built-in direct mode and command sequencer mode
 - Direct mode: Access by use of transmission FIFO/reception FIFO (up to 16 word x 32 bit)
 - Command sequencer mode: Automatic access assigned to external device area.

Clock and Reset

- Clocks

Five clock sources (two external oscillators, two internal CR oscillators, and main PLL) that are dynamically selectable.

 - Main clock : 4 MHz to 48 MHz
 - Sub clock : 30 kHz to 100 kHz
 - High-speed internal CR clock : 4 MHz
 - Low-speed internal CR clock : 100 kHz
 - Main PLL Clock
- Resets
 - Reset requests from INITX pin
 - Power on reset
 - Software reset
 - Watchdog timer reset
 - Low-voltage detector reset
 - Clock supervisor reset

Clock Supervisor (CSV)

Clocks generated by internal CR oscillators are used to supervise abnormality of the external clocks.

- External OSC clock failure (clock stop) is detected, reset is asserted.
- External OSC frequency anomaly is detected, interrupt or reset is asserted.

Low-Voltage Detector (LVD)

This Series include two-stage monitoring of voltage on the VCC pins. when the voltage falls below the voltage that has been set, the low-voltage detector function generates an interrupt or reset.

- LVD1: error reporting via interrupt
- LVD2: auto-reset operation

Low-power Consumption Mode

Six low power consumption modes are supported.

- Sleep
- Timer
- RTC
- Stop
- Deep standby RTC (selectable from with/without RAM retention)
- Deep standby stop (selectable from with/without RAM retention)

Peripheral Clock Gating

The system can reduce the current consumption of the total system with gating the operation clocks of peripheral functions not used.

VBAT

The consumption power during the RTC operation can be reduced by supplying the power supply independent from the RTC (calendar circuit)/32 kHz oscillation circuit. The following circuits can also be used.

- RTC
- 32-kHz oscillation circuit
- Power-on circuit
- Back up register: 32 bytes
- Port circuit

Debug

- Serial wire JTAG debug port (SWJ-DP)
- Embedded trace macrocells (ETM) provide comprehensive debug and trace facilities.
- AHB trace macrocells (HTM)

Unique ID

Unique value of the device (41-bit) is set.

Power Supply

- Five power supplies
 - Wide range voltage : VCC = 2.7V to 5.5V
 - Power supply for USB ch 0 I/O : USBVCC0 = 3.0V to 3.6V (when USB is used)
= 2.7V to 5.5V (when GPIO is used)
 - Power supply for USB ch 1 I/O : USBVCC1 = 3.0V to 3.6V (when USB is used)
= 2.7V to 5.5V (when GPIO is used)
 - Power supply for Ethernet-MAC I/O : ETHVCC = 3.0V to 5.5V (when Ethernet is used.)
= 2.7V to 5.5V (when GPIO is used)
 - Power supply for VBAT : VBAT = 1.65V to 5.5V

3. Product Lineup

Memory Size

Product Name		S6E2C28H/J/L	S6E2C29H/J/L	S6E2C2AH/J/L
On-chip flash memory		1024 Kbytes	1536 Kbytes	2048 Kbytes
On-chip	SRAM	128 Kbytes	192 Kbytes	256 Kbytes
	SRAM0	64 Kbytes	128 Kbytes	192 Kbytes
	SRAM1	32 Kbytes	32 Kbytes	32 Kbytes
	SRAM2	32 Kbytes	32 Kbytes	32 Kbytes

Function

Product Name		S6E2C28H0A S6E2C29H0A S6E2C2AH0A	S6E2C28J0A S6E2C29J0A S6E2C2AJ0A	S6E2C28L0A S6E2C29L0A S6E2C2AL0A
Pin count		144	176/192	216
CPU		Cortex-M4F, MPU, NVIC 128 ch		
Freq.		200 MHz		
Power supply voltage range		2.7V to 5.5V		
USB2.0 (function/host)		2 ch		
Ethernet-MAC		MII: 1 ch /RMII: 1 ch		
DMAC		8ch		
DSTC		256 ch		
External bus interface		Addr: 25-bit (Max), Data: 8/16-bit CS: 9 (Max), SRAM, NOR flash NAND flash	Addr: 25-bit (Max), Data: 8/16-bit CS: 9 (Max), SRAM, NOR flash , NAND flash SDRAM	Addr: 25-bit (Max), Data: 8/16/32-bit CS: 9 (Max), SRAM, NOR flash , NAND flash, SDRAM
Multi-function serial interface (UART/CSIO/LIN/I ² C)		16ch (Max) ch 0 to ch 7 : FIFO, ch 8 to ch 15 : No FIFO		
Base timer (PWC/Reload timer/PWM/PPG)		16 ch (Max)		
MF timer	A/D activation compare	6 ch	3 units (Max)	
	Input capture	4 ch		
	Free-run timer	3 ch		
	Output compare	6 ch		
	Waveform generator	3 ch		
	PPG	3 ch		
SD card interface		1 unit		
I ² S		-	1 unit	
HDMI-CEC/ remote control receiver		2 ch		
High-speed quad SPI		-	1 unit	
QPRC		4 ch (Max)		
Dual timer		1 unit		
Real-time clock		1 unit		
Watch counter		1 unit		
CRC accelerator		Yes (fixed, programmable)		
Watchdog timer		1 ch (SW) + 1 ch (HW)		

Product Name	S6E2C28H0A S6E2C29H0A S6E2C2AH0A	S6E2C28J0A S6E2C29J0A S6E2C2AJ0A	S6E2C28L0A S6E2C29L0A S6E2C2AL0A
External interrupts	32 pins (Max)+ NMI x 1		
I/O ports	120 pins (Max)	152 pins (Max)	190 pins (Max)
12-bit A/D converter	24 ch (3 units)	32 ch (3 units)	
12-bit D/A converter	2 units (Max)		
CSV (clock supervisor)	Yes		
LVD (low-voltage detector)	2 ch		
Built-in CR	High-speed	4 MHz ($\pm 2\%$)	
	Low-speed	100 kHz (Typ)	
Debug function	SWJ-DP/ETM/HTM		
Unique ID	Yes		

Notes:

- All signals of the peripheral function in each product cannot be allocated by limiting the pins of package.
It is necessary to use the port relocate function of the I/O port according to your function use.
- See "14.4.3 Built-In CR Oscillation Characteristics" for the accuracy of the built-in CR.

4. Packages

Package	Product Name	S6E2C28H0A S6E2C29H0A S6E2C2AH0A	S6E2C28J0A S6E2C29J0A S6E2C2AJ0A	S6E2C28L0A S6E2C29L0A S6E2C2AL0A
LQFP: FPT-144P-M08 (0.5-mm pitch)		○	-	-
LQFP: FPT-176P-M07 (0.5-mm pitch)		-	○	-
BGA : LBE192 (0.8-mm pitch)		-	○	-
LQFP: FPT-216P-M01 (0.4-mm pitch)		-	-	○

○ : Supported

Note:

- See "16. PACKAGE DIMENSIONS" for detailed information on each package.

5. Pin Assignments

FPT-144P-M08

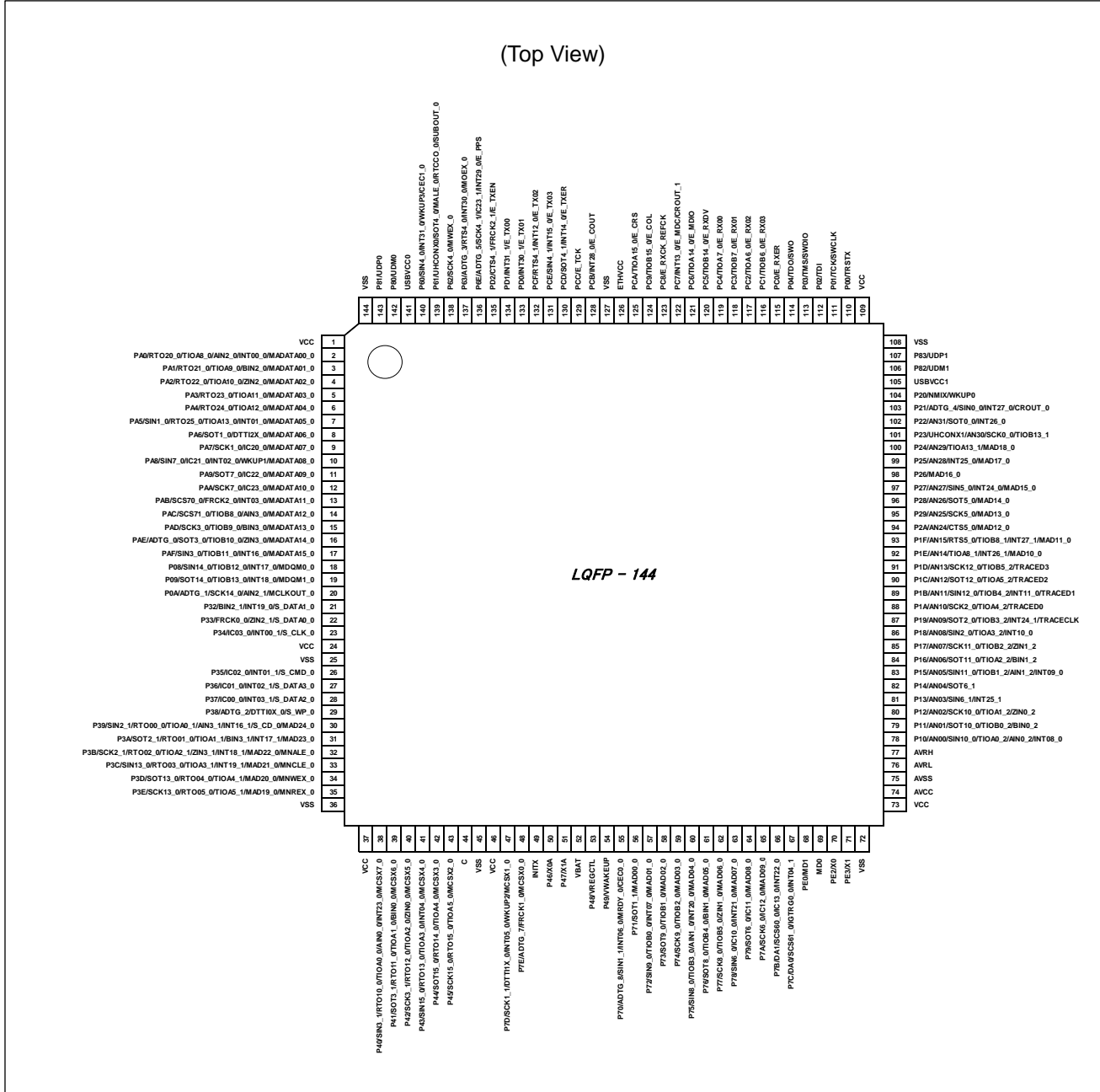

Note:

- The number after the underscore ("_") in pin names such as XXX_1 and XXX_2 indicates the relocated port number. For these pins, there are multiple pins that provide the same function for the same channel. Use the extended port function register (EPFR) to select the pin.

FPT-176P-M07

(Top View)

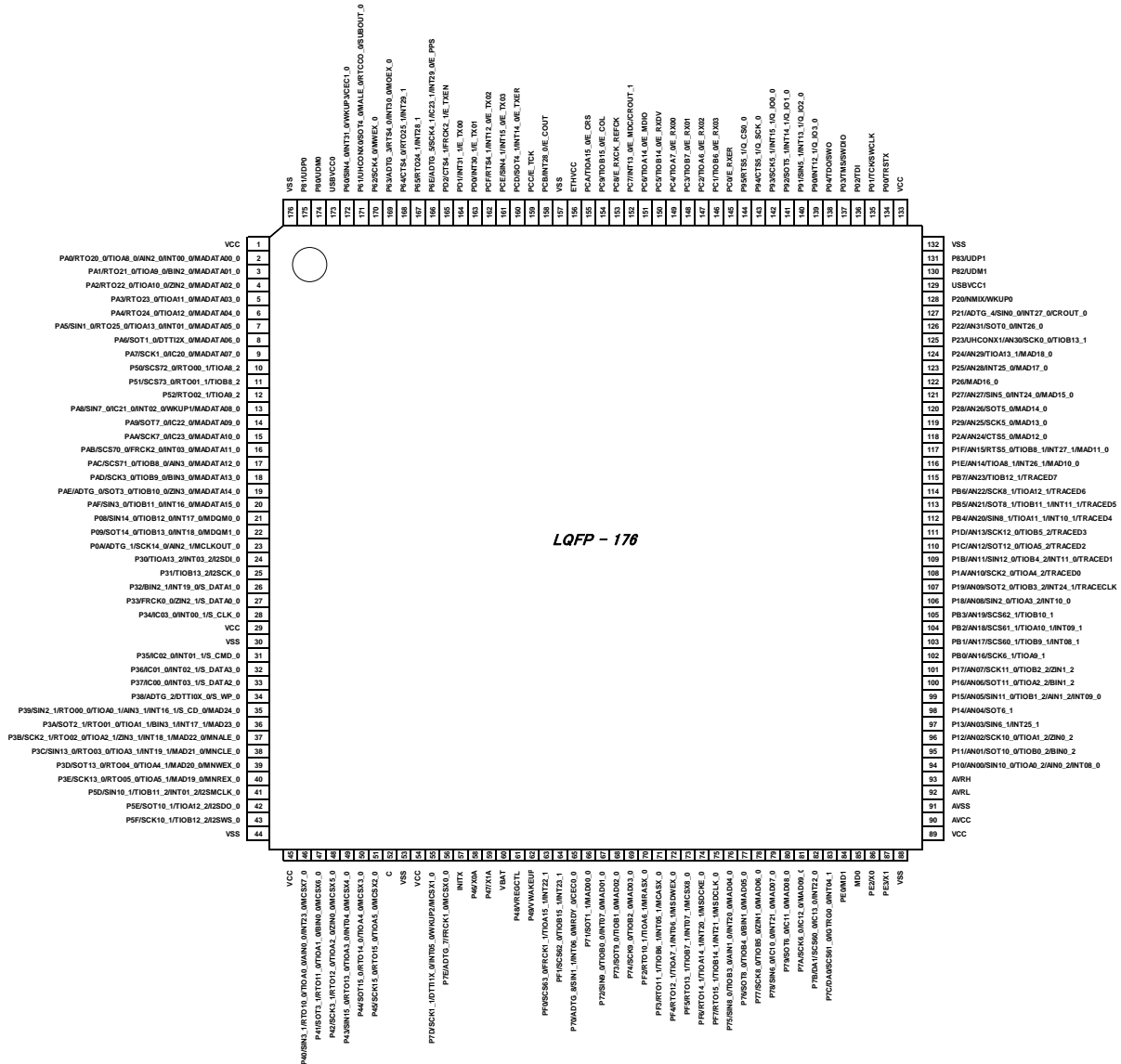

Note:

- The number after the underscore ("_") in pin names such as XXX_1 and XXX_2 indicates the relocated port number. For these pins, there are multiple pins that provide the same function for the same channel. Use the extended port function register (EPFR) to select the pin.

FPT-216P-M01

(Top View)

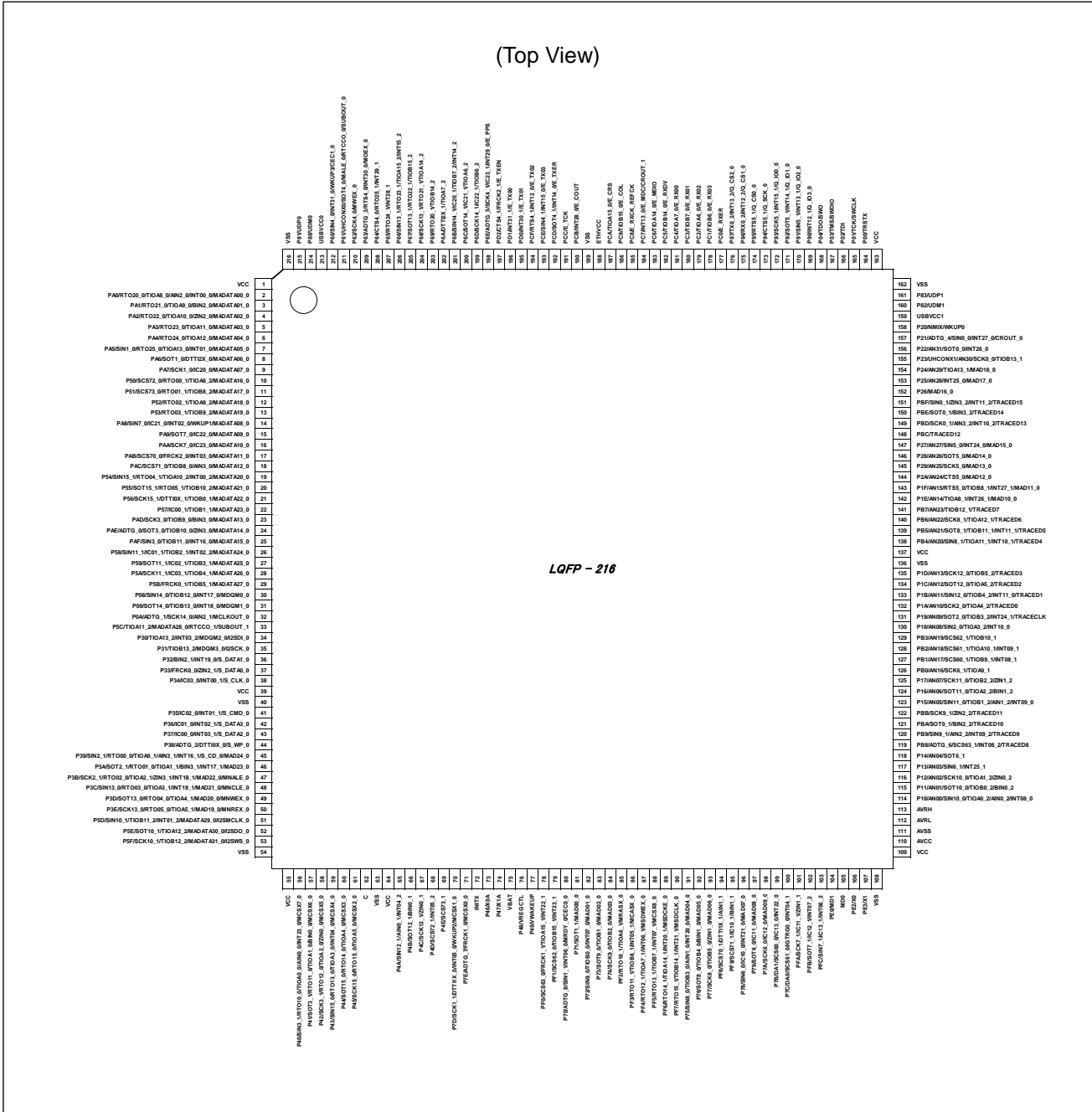

Note:

- The number after the underscore ("_") in pin names such as XXX_1 and XXX_2 indicates the relocated port number. For these pins, there are multiple pins that provide the same function for the same channel.

Use the extended port function register (EPFR) to select the pin.

LBE192

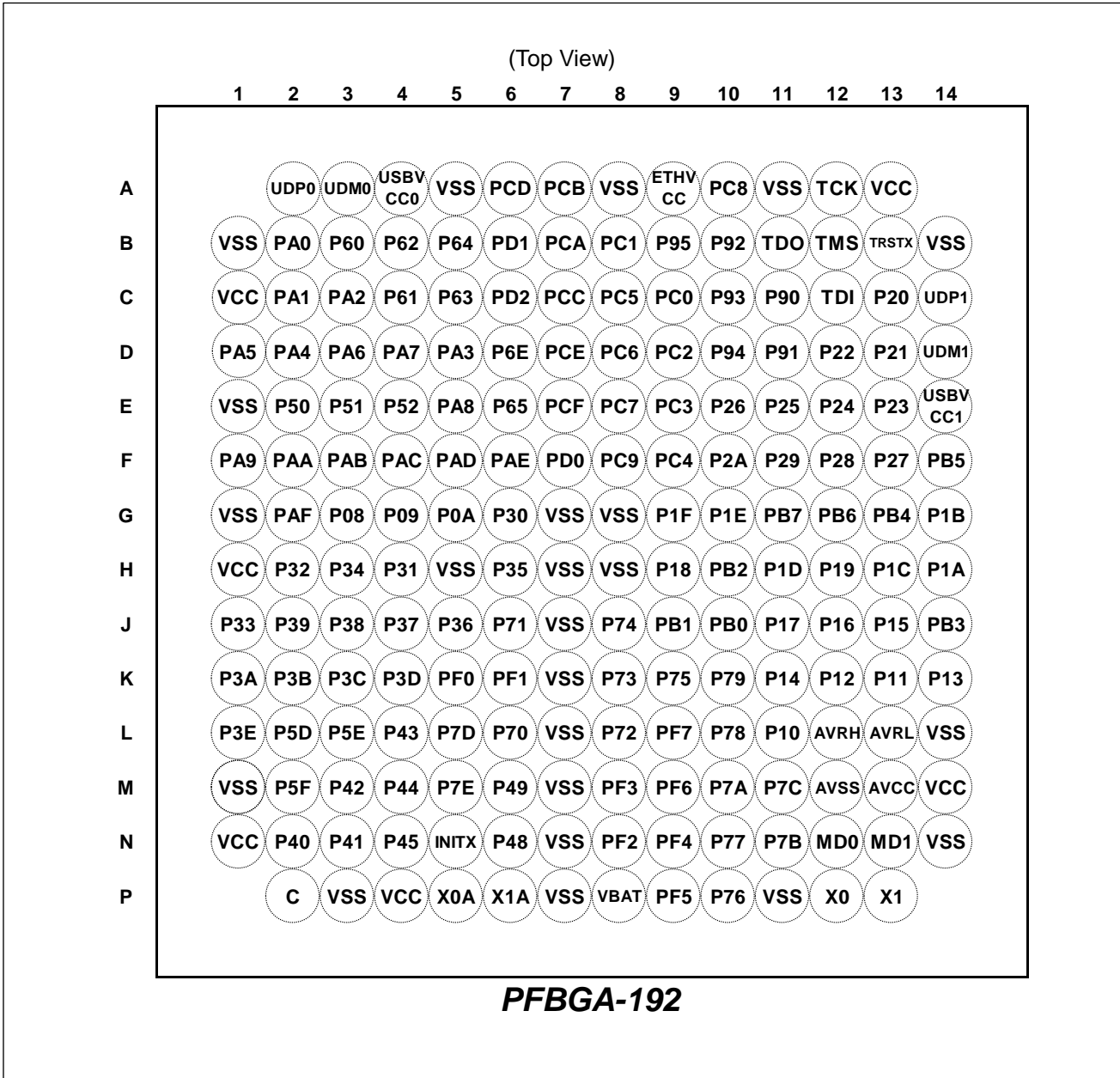

Note:

- The number after the underscore ("_") in pin names such as XXX_1 and XXX_2 indicates the relocated port number. For these pins, there are multiple pins that provide the same function for the same channel.
Use the extended port function register (EPFR) to select the pin.

6. Pin Descriptions

List of Pin Functions

The number after the underscore ("_") in pin names such as XXX_1 and XXX_2 indicates the relocated port number. For these pins, there are multiple pins that provide the same function for the same channel.

Use the extended port function register (EPFR) to select the pin.

Pin Number				Pin Name	I/O Circuit Type	Pin State Type
LQFP-216	LQFP-176	LQFP-144	LBE192			
1	1	1	C1	VCC	-	-
2	2	2	B2	PA0	G	K
				RTO20_0 (PPG20_0)		
				TIOA8_0		
				AIN2_0		
				INT00_0		
MADATA00_0						
3	3	3	C2	PA1	G	I
				RTO21_0 (PPG20_0)		
				TIOA9_0		
				BIN2_0		
MADATA01_0						
4	4	4	C3	PA2	G	I
				RTO22_0 (PPG22_0)		
				TIOA10_0		
				ZIN2_0		
MADATA02_0						
5	5	5	D5	PA3	G	I
				RTO23_0 (PPG22_0)		
				TIOA11_0		
MADATA03_0						
6	6	6	D2	PA4	G	I
				RTO24_0 (PPG24_0)		
				TIOA12_0		
MADATA04_0						
7	7	7	D1	PA5	G	K
				SIN1_0		
				RTO25_0 (PPG24_0)		
				TIOA13_0		
				INT01_0		
MADATA05_0						



Pin Number				Pin Name	I/O Circuit Type	Pin State Type
LQFP-216	LQFP-176	LQFP-144	LBE192			
8	8	8	D3	PA6	E	I
				SOT1_0 (SDA1_0))		
				DTTI2X_0		
				MADATA06_0		
9	9	9	D4	PA7	E	I
				SCK1_0 (SCL1_0)		
				IC20_0		
				MADATA07_0		
10	10	-	E2	P50	E	I
				SCS72_0		
				RTO00_1 (PPG00_1)		
				TIOA8_2		
				MADATA16_0		
11	11	-	E3	P51	E	I
				SCS73_0		
				RTO01_1 (PPG00_1)		
				TIOB8_2		
				MADATA17_0		
12	12	-	E4	P52	E	I
				RTO02_1 (PPG02_1)		
				TIOA9_2		
				MADATA18_0		
13	-	-	-	P53	E	I
				RTO03_1 (PPG02_1)		
				TIOB9_2		
				MADATA19_0		
14	13	10	E5	PA8	I	Q
				SIN7_0		
				IC21_0		
				INT02_0		
				WKUP1		
				MADATA08_0		
15	14	11	F1	PA9	N	I
				SOT7_0 (SDA7_0)		
				IC22_0		
				MADATA09_0		
16	15	12	F2	PAA	N	I
				SCK7_0 (SCL7_0)		
				IC23_0		
				MADATA10_0		

Pin Number				Pin Name	I/O Circuit Type	Pin State Type
LQFP-216	LQFP-176	LQFP-144	LBE192			
17	16	13	F3	PAB	E	K
				SCS70_0		
				FRCK2_0		
				INT03_0		
				MADATA11_0		
18	17	14	F4	PAC	E	I
				SCS71_0		
				TIOB8_0		
				AIN3_0		
				MADATA12_0		
19	-	-	-	P54	E	K
				SIN15_1		
				RTO04_1 (PPG04_1)		
				TIOA10_2		
				INT00_2		
				MADATA20_0		
20	-	-	-	P55	E	I
				SOT15_1 (SDA15_1)		
				RTO05_1 (PPG04_1)		
				TIOB10_2		
				MADATA21_0		
21	-	-	-	P56	E	I
				SCK15_1 (SCL15_1)		
				DTTI0X_1		
				TIOB0_1		
				MADATA22_0		
22	-	-	-	P57	E	I
				IC00_1		
				TIOB1_1		
				MADATA23_0		
23	18	15	F5	PAD	N	I
				SCK3_0 (SCL3_0)		
				TIOB9_0		
				BIN3_0		
				MADATA13_0		



Pin Number				Pin Name	I/O Circuit Type	Pin State Type
LQFP-216	LQFP-176	LQFP-144	LBE192			
24	19	16	F6	PAE	N	I
				ADTG_0		
				SOT3_0 (SDA3_0)		
				TIOB10_0		
				ZIN3_0		
				MADATA14_0		
25	20	17	G2	PAF	I	K
				SIN3_0		
				TIOB11_0		
				INT16_0 MADATA15_0		
26	-	-	-	P58	E	K
				SIN11_1		
				IC01_1		
				TIOB2_1		
				INT02_2 MADATA24_0		
27	-	-	-	P59	E	I
				SOT11_1 (SDA11_1)		
				IC02_1		
				TIOB3_1		
				MADATA25_0		
28	-	-	-	P5A	E	I
				SCK11_1 (SCL11_1)		
				IC03_1		
				TIOB4_1		
				MADATA26_0		
29	-	-	-	P5B	E	I
				FRCK0_1		
				TIOB5_1		
				MADATA27_0		
30	21	18	G3	P08	E	K
				SIN14_0		
				TIOB12_0		
				INT17_0		
				MDQM0_0		
31	22	19	G4	P09	E	K
				SOT14_0 (SDA14_0)		
				TIOB13_0		
				INT18_0		
				MDQM1_0		

Pin Number				Pin Name	I/O Circuit Type	Pin State Type
LQFP-216	LQFP-176	LQFP-144	LBE192			
32	23	20	G5	P0A	L	I
				ADTG_1		
				SCK14_0 (SCL14_0)		
				AIN2_1		
				MCLKOUT_0		
33	-	-	-	P5C	E	I
				TIOA11_2		
				MADATA28_0		
				RTCCO_1		
				SUBOUT_1		
34	24	-	G6	P30	E	K
				TIOA13_2		
				INT03_2		
				MDQM2_0		
				I2SDI_0		
35	25	-	H4	P31	E	I
				TIOB13_2		
				MDQM3_0		
				I2SCK_0		
36	26	21	H2	P32	L	K
				BIN2_1		
				INT19_0		
				S_DATA1_0		
37	27	22	J1	P33	L	I
				FRCK0_0		
				ZIN2_1		
				S_DATA0_0		
38	28	23	H3	P34	L	K
				IC03_0		
				INT00_1		
				S_CLK_0		
39	29	24	H1	VCC	-	-
40	30	25	H5	VSS	-	-
41	31	26	H6	P35	L	K
				IC02_0		
				INT01_1		
				S_CMD_0		
42	32	27	J5	P36	L	K
				IC01_0		
				INT02_1		
				S_DATA3_0		
43	33	28	J4	P37	L	K
				IC00_0		
				INT03_1		
				S_DATA2_0		



Pin Number				Pin Name	I/O Circuit Type	Pin State Type
LQFP-216	LQFP-176	LQFP-144	LBE192			
44	34	29	J3	P38	E	I
				ADTG_2		
				DTTI0X_0		
				S_WP_0		
45	35	30	J2	P39	G	K
				SIN2_1		
				RTO00_0 (PPG00_0)		
				TIOA0_1		
				AIN3_1		
				INT16_1		
				S_CD_0		
MAD24_0						
46	36	31	K1	P3A	G	K
				SOT2_1 (SDA2_1)		
				RTO01_0 (PPG00_0)		
				TIOA1_1		
				BIN3_1		
				INT17_1		
MAD23_0						
47	37	32	K2	P3B	G	K
				SCK2_1 (SCL2_1)		
				RTO02_0 (PPG02_0)		
				TIOA2_1		
				ZIN3_1		
				INT18_1		
				MAD22_0		
MNALE_0						
48	38	33	K3	P3C	G	K
				SIN13_0		
				RTO03_0 (PPG02_0)		
				TIOA3_1		
				INT19_1		
				MAD21_0		
MNCLE_0						
49	39	34	K4	P3D	G	I
				SOT13_0 (SDA13_0)		
				RTO04_0 (PPG04_0)		
				TIOA4_1		
				MAD20_0		
MNWEX_0						

Pin Number				Pin Name	I/O Circuit Type	Pin State Type
LQFP-216	LQFP-176	LQFP-144	LBE192			
50	40	35	L1	P3E	G	I
				SCK13_0 (SCL13_0)		
				RTO05_0 (PPG04_0)		
				TIOA5_1		
				MAD19_0		
				MNREX_0		
51	41	-	L2	P5D	E	K
				SIN10_1		
				TIOB11_2		
				INT01_2		
				MADATA29_0		
I2SMCLK_0						
52	42	-	L3	P5E	E	I
				SOT10_1 (SDA10_1)		
				TIOA12_2		
				MADATA30_0		
53	43	-	M2	P5F	E	I
				SCK10_1 (SCL10_1)		
				TIOB12_2		
				MADATA31_0		
54	44	36	M1	VSS	-	-
				55		
56	46	38	N2	P40	G	K
				SIN3_1		
				RTO10_0 (PPG10_0)		
				TIOA0_0		
				AIN0_0		
				INT23_0		
				MCSX7_0		
57	47	39	N3	P41	G	I
				SOT3_1 (SDA3_1)		
				RTO11_0 (PPG10_0)		
				TIOA1_0		
				BIN0_0		
				MCSX6_0		



Pin Number				Pin Name	I/O Circuit Type	Pin State Type
LQFP-216	LQFP-176	LQFP-144	LBE192			
58	48	40	M3	P42	G	I
				SCK3_1 (SCL3_1)		
				RTO12_0 (PPG12_0)		
				TIOA2_0		
				ZIN0_0		
MCSX5_0						
59	49	41	L4	P43	G	K
				SIN15_0		
				RTO13_0 (PPG12_0)		
				TIOA3_0		
				INT04_0		
MCSX4_0						
60	50	42	M4	P44	G	I
				SOT15_0 (SDA15_0)		
				RTO14_0 (PPG14_0)		
				TIOA4_0		
				MCSX3_0		
61	51	43	N4	P45	G	I
				SCK15_0 (SCL15_0)		
				RTO15_0 (PPG14_0)		
				TIOA5_0		
				MCSX2_0		
62	52	44	P2	C	-	-
63	53	45	P3	VSS	-	-
64	54	46	P4	VCC	-	-
65	-	-	-	P4A	E	K
				SIN12_1		
				AIN0_1		
				INT04_2		
66	-	-	-	P4B	E	I
				SOT12_1 (SDA12_1)		
				BIN0_1		
67	-	-	-	P4C	E	I
				SCK12_1 (SCL12_1)		
				ZIN0_1		
68	-	-	-	P4D	E	K
				SCS72_1		
				INT05_2		

Pin Number				Pin Name	I/O Circuit Type	Pin State Type
LQFP-216	LQFP-176	LQFP-144	LBE192			
69	-	-	-	P4E	E	I
				SCS73_1		
70	55	47	L5	P7D	L	Q
				SCK1_1 (SCL1_1)		
				RX2_0		
				DTT1X_0		
				INT05_0		
				WKUP2		
				MCSX1_0		
71	56	48	M5	P7E	L	I
				ADTG_7		
				FRCK1_0		
				MCSX0_0		
72	57	49	N5	INITX	B	C
73	58	50	P5	P46	P	S
				X0A		
74	59	51	P6	P47	Q	T
				X1A		
75	60	52	P8	VBAT	-	-
76	61	53	N6	P48	O	U
				VREGCTL		
77	62	54	M6	P49	O	U
				VWAKEUP		
78	63	-	K5	PF0	E	K
				SCS63_0		
				FRCK1_1		
				TIOA15_1		
79	64	-	K6	INT22_1	E	K
				PF1		
				SCS62_0		
				TIOB15_1		
80	65	55	L6	INT23_1	I	X
				P70		
				ADTG_8		
				SIN1_1		
				INT06_0		
MRDY_0						
81	66	56	J6	CEC0_0	E	I
				P71		
				SOT1_1 (SDA1_1)		
				MAD00_0		
82	67	57	L8	P72	E	K
				SIN9_0		
				TIOB0_0		



Pin Number				Pin Name	I/O Circuit Type	Pin State Type
LQFP-216	LQFP-176	LQFP-144	LBE192			
				INT07_0		
				MAD01_0		
83	68	58	K8	P73	E	I
				SOT9_0 (SDA9_0)		
				TIOB1_0		
				MAD02_0		
84	69	59	J8	P74	E	I
				SCK9_0 (SCL9_0)		
				TIOB2_0 MAD03_0		
85	70	-	N8	PF2	L	I
				RTO10_1 (PPG10_1)		
				TIOA6_1		
				MRASX_0		
86	71	-	M8	PF3	L	K
				RTO11_1 (PPG10_1)		
				TIOB6_1		
				INT05_1		
				MCASX_0		
87	72	-	N9	PF4	L	K
				RTO12_1 (PPG12_1)		
				TIOA7_1		
				INT06_1		
				MSDWEX_0		
88	73	-	P9	PF5	L	K
				RTO13_1 (PPG12_1)		
				TIOB7_1		
				INT07_1		
				MCSX8_0		
89	74	-	M9	PF6	L	K
				RTO14_1 (PPG14_1)		
				TIOA14_1		
				INT20_1		
				MSDCKE_0		

Pin Number				Pin Name	I/O Circuit Type	Pin State Type
LQFP-216	LQFP-176	LQFP-144	LBE192			
90	75	-	L9	PF7	L	K
				RTO15_1 (PPG14_1)		
				TIOB14_1		
				INT21_1		
				MSDCLK_0		
91	76	60	K9	P75	E	K
				SIN8_0		
				TIOB3_0		
				AIN1_0		
				INT20_0		
MAD04_0						
92	77	61	P10	P76	E	I
				SOT8_0 (SDA8_0)		
				TIOB4_0		
				BIN1_0		
				MAD05_0		
93	78	62	N10	P77	E	I
				SCK8_0 (SCL8_0)		
				TIOB5_0		
				ZIN1_0		
				MAD06_0		
94	-	-	-	PF8	E	I
				SCS70_1		
				DTT11X_1		
				AIN1_1		
95	-	-	-	PF9	E	I
				SCS71_1		
				IC10_1		
				BIN1_1		
96	79	63	L10	P78	E	K
				SIN6_0		
				IC10_0		
				INT21_0		
				MAD07_0		
97	80	64	K10	P79	L	I
				SOT6_0 (SDA6_0)		
				IC11_0		
				MAD08_0		
98	81	65	M10	P7A	L	I
				SCK6_0 (SCL6_0)		
				IC12_0		
				MAD09_0		



Pin Number				Pin Name	I/O Circuit Type	Pin State Type
LQFP-216	LQFP-176	LQFP-144	LBE192			
99	82	66	N11	P7B	R	J
				DA1		
				SCS60_0		
				IC13_0		
				INT22_0		
100	83	67	M11	P7C	R	J
				DA0		
				SCS61_0		
				INT04_1		
101	-	-	-	PFA	E	I
				SCK7_1 (SCL7_1)		
				IC11_1		
				ZIN1_1		
102	-	-	-	PFB	E	K
				SOT7_1 (SDA7_1)		
				IC12_1		
				INT07_2		
103	-	-	-	PFC	E	K
				SIN7_1		
				IC13_1		
				INT06_2		
104	84	68	N13	PE0	C	E
				MD1		
105	85	69	N12	MD0	J	D
106	86	70	P12	PE2	A	A
				X0		
107	87	71	P13	PE3	A	B
				X1		
108	88	72	N14	VSS	-	-
109	89	73	M14	VCC	-	-
110	90	74	M13	AVCC	-	-
111	91	75	M12	AVSS	-	-
112	92	76	L13	AVRL	-	-
113	93	77	L12	AVRH	-	-
114	94	78	L11	P10	F	M
				AN00		
				SIN10_0		
				TIOA0_2		
				AIN0_2		
				INT08_0		

Pin Number				Pin Name	I/O Circuit Type	Pin State Type
LQFP-216	LQFP-176	LQFP-144	LBE192			
115	95	79	K13	P11	F	L
				AN01		
				SOT10_0 (SDA10_0)		
				TIOB0_2		
				BIN0_2		
116	96	80	K12	P12	F	L
				AN02		
				SCK10_0 (SCL10_0)		
				TIOA1_2		
				ZIN0_2		
117	97	81	K14	P13	F	M
				AN03		
				SIN6_1		
				INT25_1		
118	98	82	K11	P14	F	L
				AN04		
				SOT6_1 (SDA6_1)		
119	-	-	-	PB8	E	O
				ADTG_6		
				SCS63_1		
				INT08_2		
				TRACED8		
120	-	-	-	PB9	E	O
				SIN9_1		
				AIN2_2		
				INT09_2		
				TRACED9		
121	-	-	-	PBA	E	N
				SOT9_1 (SDA9_1)		
				BIN2_2		
				TRACED10		
122	-	-	-	PBB	E	N
				SCK9_1 (SCL9_1)		
				ZIN2_2		
				TRACED11		
123	99	83	J13	P15	F	M
				AN05		
				SIN11_0		
				TIOB1_2		
				AIN1_2		
				INT09_0		



Pin Number				Pin Name	I/O Circuit Type	Pin State Type
LQFP-216	LQFP-176	LQFP-144	LBE192			
124	100	84	J12	P16	F	L
				AN06		
				SOT11_0 (SDA11_0)		
				TIOA2_2		
				BIN1_2		
125	101	85	J11	P17	F	L
				AN07		
				SCK11_0 (SCL11_0)		
				TIOB2_2		
				ZIN1_2		
126	102	-	J10	PB0	F	L
				AN16		
				SCK6_1 (SCL6_1)		
				TIOA9_1		
127	103	-	J9	PB1	F	M
				AN17		
				SCS60_1		
				TIOB9_1		
				INT08_1		
128	104	-	H10	PB2	F	M
				AN18		
				SCS61_1		
				TIOA10_1		
				INT09_1		
129	105	-	J14	PB3	F	L
				AN19		
				SCS62_1		
				TIOB10_1		
130	106	86	H9	P18	F	M
				AN08		
				SIN2_0		
				TIOA3_2		
				INT10_0		
131	107	87	H12	P19	F	O
				AN09		
				SOT2_0 (SDA2_0)		
				TIOB3_2		
				INT24_1		
				TRACECLK		

Pin Number				Pin Name	I/O Circuit Type	Pin State Type
LQFP-216	LQFP-176	LQFP-144	LBE192			
132	108	88	H14	P1A	F	N
				AN10		
				SCK2_0 (SCL2_0)		
				TIOA4_2		
				TRACED0		
133	109	89	G14	P1B	F	O
				AN11		
				SIN12_0		
				TIOB4_2		
				INT11_0		
TRACED1						
134	110	90	H13	P1C	F	N
				AN12		
				SOT12_0 (SDA12_0)		
				TIOA5_2		
TRACED2						
135	111	91	H11	P1D	F	N
				AN13		
				SCK12_0 (SCL12_0)		
				TIOB5_2		
TRACED3						
136	-	-	-	VSS	-	-
137	-	-	-	VCC	-	-
138	112	-	G13	PB4	F	O
				AN20		
				SIN8_1		
				TIOA11_1		
				INT10_1		
TRACED4						
139	113	-	F14	PB5	F	O
				AN21		
				SOT8_1 (SDA8_1)		
				TIOB11_1		
				INT11_1		
TRACED5						
140	114	-	G12	PB6	F	N
				AN22		
				SCK8_1 (SCL8_1)		
				TIOA12_1		
TRACED6						



Pin Number				Pin Name	I/O Circuit Type	Pin State Type
LQFP-216	LQFP-176	LQFP-144	LBE192			
141	115	-	G11	PB7	F	N
				AN23		
				TIOB12_1		
				TRACED7		
142	116	92	G10	P1E	F	M
				AN14		
				TIOA8_1		
				INT26_1		
143	117	93	G9	MAD10_0	F	M
				P1F		
				AN15		
				RTS5_0		
				TIOB8_1		
144	118	94	F10	INT27_1	F	L
				MAD11_0		
				P2A		
				AN24		
145	119	95	F11	CTS5_0	F	L
				MAD12_0		
				P29		
				AN25		
146	120	96	F12	SCK5_0 (SCL5_0)	F	L
				MAD13_0		
				P28		
				AN26		
147	121	97	F13	SOT5_0 (SDA5_0)	F	M
				MAD14_0		
				P27		
				AN27		
148	-	-	-	SIN5_0	E	N
				INT24_0		
149	-	-	-	MAD15_0	E	O
				PBC		
				TRACED12		
				PBD		
				SCK0_1 (SCL0_1)		
AIN3_2						
				INT10_2		
				TRACED13		

Pin Number				Pin Name	I/O Circuit Type	Pin State Type
LQFP-216	LQFP-176	LQFP-144	LBE192			
150	-	-	-	PBE	E	N
				SOT0_1 (SDA0_1)		
				BIN3_2		
				TRACED14		
151	-	-	-	PBF	E	O
				SIN0_1		
				ZIN3_2		
				INT11_2		
152	122	98	E10	P26	E	I
				MAD16_0		
153	123	99	E11	P25	F	M
				AN28		
				INT25_0		
				MAD17_0		
154	124	100	E12	P24	F	L
				AN29		
				TIOA13_1		
				MAD18_0		
155	125	101	E13	P23	F	L
				UHCONX1		
				AN30		
				SCK0_0 (SCL0_0)		
				TIOB13_1		
156	126	102	D12	P22	F	M
				AN31		
				SOT0_0 (SDA0_0)		
				INT26_0		
157	127	103	D13	P21	I	K
				ADTG_4		
				SIN0_0		
				INT27_0		
				CROUT_0		
158	128	104	C13	P20	I	F
				NMIX		
				WKUP0		
159	129	105	E14	USBVCC1	-	-
160	130	106	D14	P82	H	R
				UDM1		
161	131	107	C14	P83	H	R
				UDP1		
162	132	108	B14	VSS	-	-
163	133	109	A13	VCC	-	-
164	134	110	B13	P00	E	G
				TRSTX		



Pin Number				Pin Name	I/O Circuit Type	Pin State Type
LQFP-216	LQFP-176	LQFP-144	LBE192			
165	135	111	A12	P01	E	G
				TCK		
				SWCLK		
166	136	112	C12	P02	E	G
				TDI		
167	137	113	B12	P03	E	G
				TMS		
				SWDIO		
168	138	114	B11	P04	E	G
				TDO		
				SWO		
169	139	-	C11	P90	S	K
				INT12_1		
				Q_IO3_0		
170	140	-	D11	P91	S	K
				SIN5_1		
				INT13_1		
				Q_IO2_0		
171	141	-	B10	P92	S	K
				SOT5_1 (SDA5_1)		
				INT14_1		
				Q_IO1_0		
172	142	-	C10	P93	S	K
				SCK5_1 (SCL5_1)		
				INT15_1		
				Q_IO0_0		
173	143	-	D10	P94	S	I
				CTS5_1		
				Q_SCK_0		
174	144	-	B9	P95	S	I
				RTS5_1		
				Q_CS0_0		
175	-	-	-	P96	S	K
				INT12_2		
				Q_CS1_0		
176	-	-	-	P97	S	K
				INT13_2		
				Q_CS2_0		
177	145	115	C9	PC0	K	V
				E_RXER		
178	146	116	B8	PC1	K	V
				TIOB6_0		
				E_RX03		
179	147	117	D9	PC2	K	V
				TIOA6_0		
				E_RX02		

Pin Number				Pin Name	I/O Circuit Type	Pin State Type
LQFP-216	LQFP-176	LQFP-144	LBE192			
180	148	118	E9	PC3	K	V
				TIOB7_0		
				E_RX01		
181	149	119	F9	PC4	K	V
				TIOA7_0		
				E_RX00		
182	150	120	C8	PC5	K	V
				TIOB14_0		
				E_RXDV		
183	151	121	D8	PC6	K	V
				TIOA14_0		
				E_MDIO		
184	152	122	E8	PC7	E	W
				INT13_0		
				E_MDC		
				CROUT_1		
185	153	123	A10	PC8	K	V
				E_RXCK_REFCK		
186	154	124	F8	PC9	K	V
				TIOB15_0		
				E_COL		
187	155	125	B7	PCA	K	V
				TIOA15_0		
				E_CRS		
188	156	126	A9	ETHVCC	-	-
189	157	127	A8	VSS	-	-
190	158	128	A7	PCB	L	W
				INT28_0		
				E_COUT		
191	159	129	C7	PCC	K	V
				E_TCK		
192	160	130	A6	PCD	L	W
				SOT4_1 (SDA4_1)		
				INT14_0		
				E_TXER		
193	161	131	D7	PCE	L	W
				SIN4_1		
				INT15_0		
				E_TX03		
194	162	132	E7	PCF	L	W
				RTS4_1		
				INT12_0		
				E_TX02		
195	163	133	F7	PD0	L	W
				INT30_1		
				E_TX01		



Pin Number				Pin Name	I/O Circuit Type	Pin State Type
LQFP-216	LQFP-176	LQFP-144	LBE192			
196	164	134	B6	PD1	L	W
				INT31_1		
				E_TX00		
197	165	135	C6	PD2	L	V
				CTS4_1		
				FRCK2_1		
				E_TXEN		
198	166	136	D6	P6E	E	W
				ADTG_5		
				SCK4_1 (SCL4_1)		
				IC23_1		
				INT29_0		
				E_PPS		
199	-	-	-	P6D	E	I
				SCK14_1 (SCL14_1)		
				IC22_1		
				TIOB6_2		
200	-	-	-	P6C	E	I
				SOT14_1 (SDA14_1)		
				IC21_1		
				TIOA6_2		
201	-	-	-	P6B	E	K
				SIN14_1		
				IC20_1		
				TIOB7_2		
				INT14_2		
202	-	-	-	P6A	E	I
				DTTI2X_1		
				TIOA7_2		
203	-	-	-	P69	E	I
				RTO20_1 (PPG20_1)		
				TIOB14_2		
204	-	-	-	P68	E	I
				SCK13_1 (SCL13_0)		
				RTO21_1 (PPG20_1)		
				TIOA14_2		
205	-	-	-	P67	E	I
				SOT13_1 (SDA13_1)		
				RTO22_1 (PPG22_1)		
				TIOB15_2		

Pin Number				Pin Name	I/O Circuit Type	Pin State Type
LQFP-216	LQFP-176	LQFP-144	LBE192			
206	-	-	-	P66	E	K
				SIN13_1		
				RTO23_1 (PPG22_1)		
				TIOA15_2		
				INT15_2		
207	167	-	E6	P65	E	K
				RTO24_1 (PPG24_1)		
				INT28_1		
208	168	-	B5	P64	I	K
				CTS4_0		
				RTO25_1 (PPG24_1)		
				INT29_1		
209	169	137	C5	P63	L	K
				ADTG_3		
				RTS4_0		
				INT30_0		
				MOEX_0		
210	170	138	B4	P62	L	I
				SCK4_0 (SCL4_0)		
				MWEX_0		
211	171	139	C4	P61	L	I
				UHCONX0		
				SOT4_0 (SDA4_0)		
				MALE_0		
				RTCCO_0		
				SUBOUT_0		
212	172	140	B3	P60	I	Y
				SIN4_0		
				INT31_0		
				WKUP3		
				CEC1_0		
213	173	141	A4	USBVCC0	-	-
214	174	142	A3	P80	H	R
				UDM0		
215	175	143	A2	P81	H	R
				UDP0		

Pin Number				Pin Name	I/O Circuit Type	Pin State Type
LQFP-216	LQFP-176	LQFP-144	LBE192			
216	176	144	B1	VSS	-	-
			E1			
-	-	-	G1		-	-
-	-	-	P7		-	-
-	-	-	P11		-	-
-	-	-	L14		-	-
-	-	-	A11		-	-
-	-	-	A5		-	-
-	-	-	N7		-	-
-	-	-	M7		-	-
-	-	-	L7		-	-
-	-	-	K7		-	-
-	-	-	J7		-	-
--	-	-	G7		-	-
-	-	-	H7		-	-
-	-	-	H8		-	-
-	-	-	G8		-	-

Signal Descriptions

The number after the underscore ("_") in pin names such as XXX_1 and XXX_2 indicates the relocated port number. For these pins, there are multiple pins that provide the same function for the same channel.

Use the extended port function register (EPFR) to select the pin.

Module	Pin Name	Function	Pin Number			
			LQFP 216	LQFP 176	LQFP 144	LBE 192
A/D converter	ADTG_0	A/D converter external trigger input pin	24	19	16	F6
	ADTG_1		32	23	20	G5
	ADTG_2		44	34	29	J3
	ADTG_3		209	169	137	C5
	ADTG_4		157	127	103	D13
	ADTG_5		198	166	136	D6
	ADTG_6		119	-	-	-
	ADTG_7		71	56	48	M5
	ADTG_8		80	65	55	L6
	AN00	A/D converter analog input pin. ANxx describes A/D converter ch xx.	114	94	78	L11
	AN01		115	95	79	K13
	AN02		116	96	80	K12
	AN03		117	97	81	K14
	AN04		118	98	82	K11
	AN05		123	99	83	J13
	AN06		124	100	84	J12
	AN07		125	101	85	J11
	AN08		130	106	86	H9
	AN09		131	107	87	H12
	AN10		132	108	88	H14
	AN11		133	109	89	G14
	AN12		134	110	90	H13
	AN13		135	111	91	H11
	AN14		142	116	92	G10
	AN15		143	117	93	G9
	AN16		126	102	-	J10
	AN17		127	103	-	J9
	AN18		128	104	-	H10
	AN19		129	105	-	J14
	AN20		138	112	-	G13
	AN21		139	113	-	F14
	AN22		140	114	-	G12
	AN23		141	115	-	G11
AN24	144		118	94	F10	
AN25	145		119	95	F11	
AN26	146		120	96	F12	
AN27	147		121	97	F13	
AN28	153		123	99	E11	
AN29	154		124	100	E12	
AN30	155		125	101	E13	
AN31	156	126	102	D12		

Module	Pin Name	Function	Pin Number			
			LQFP 216	LQFP 176	LQFP 144	LBE 192
Base Timer 0	TIOA0_0	Base Timer ch 0 TIOA pin	56	46	38	N2
	TIOA0_1		45	35	30	J2
	TIOA0_2		114	94	78	L11
	TIOB0_0	Base Timer ch 0 TIOB pin	82	67	57	L8
	TIOB0_1		21	-	-	-
	TIOB0_2		115	95	79	K13
Base Timer 1	TIOA1_0	Base Timer ch 1 TIOA pin	57	47	39	N3
	TIOA1_1		46	36	31	K1
	TIOA1_2		116	96	80	K12
	TIOB1_0	Base Timer ch 1 TIOB pin	83	68	58	K8
	TIOB1_1		22	-	-	-
	TIOB1_2		123	99	83	J13
Base Timer 2	TIOA2_0	Base Timer ch 2 TIOA pin	58	48	40	M3
	TIOA2_1		47	37	32	K2
	TIOA2_2		124	100	84	J12
	TIOB2_0	Base Timer ch 2 TIOB pin	84	69	59	J8
	TIOB2_1		26	-	-	-
	TIOB2_2		125	101	85	J11
Base Timer 3	TIOA3_0	Base Timer ch 3 TIOA pin	59	49	41	L4
	TIOA3_1		48	38	33	K3
	TIOA3_2		130	106	86	H9
	TIOB3_0	Base Timer ch 3 TIOB pin	91	76	60	K9
	TIOB3_1		27	-	-	-
	TIOB3_2		131	107	87	H12
Base Timer 4	TIOA4_0	Base Timer ch 4 TIOA pin	60	50	42	M4
	TIOA4_1		49	39	34	K4
	TIOA4_2		132	108	88	H14
	TIOB4_0	Base Timer ch 4 TIOB pin	92	77	61	P10
	TIOB4_1		28	-	-	-
	TIOB4_2		133	109	89	G14
Base Timer 5	TIOA5_0	Base Timer ch 5 TIOA pin	61	51	43	N4
	TIOA5_1		50	40	35	L1
	TIOA5_2		134	110	90	H13
	TIOB5_0	Base Timer ch 5 TIOB pin	93	78	62	N10
	TIOB5_1		29	-	-	-
	TIOB5_2		135	111	91	H11
Base Timer 6	TIOA6_0	Base Timer ch 6 TIOA pin	179	147	117	D9
	TIOA6_1		85	70	-	N8
	TIOA6_2		200	-	-	-
	TIOB6_0	Base Timer ch 6 TIOB pin	178	146	116	B8
	TIOB6_1		86	71	-	M8
	TIOB6_2		199	-	-	-

Module	Pin Name	Function	Pin Number			
			LQFP 216	LQFP 176	LQFP 144	LBE 192
Base Timer 7	TIOA7_0	Base Timer ch 7 TIOA pin	181	149	119	F9
	TIOA7_1		87	72	-	N9
	TIOA7_2		202	-	-	-
	TIOB7_0	Base Timer ch 7 TIOB pin	180	148	118	E9
	TIOB7_1		88	73	-	P9
	TIOB7_2		201	-	-	-
Base Timer 8	TIOA8_0	Base Timer ch 8 TIOA pin	2	2	2	B2
	TIOA8_1		142	116	92	G10
	TIOA8_2		10	10	-	E2
	TIOB8_0	Base Timer ch 8 TIOB pin	18	17	14	F4
	TIOB8_1		143	117	93	G9
	TIOB8_2		11	11	-	E3
Base Timer 9	TIOA9_0	Base Timer ch 9 TIOA pin	3	3	3	C2
	TIOA9_1		126	102	-	J10
	TIOA9_2		12	12	-	E4
	TIOB9_0	Base Timer ch 9 TIOB pin	23	18	15	F5
	TIOB9_1		127	103	-	J9
	TIOB9_2		13	-	-	-
Base Timer 10	TIOA10_0	Base Timer ch 10 TIOA pin	4	4	4	C3
	TIOA10_1		128	104	-	H10
	TIOA10_2		19	-	-	-
	TIOB10_0	Base Timer ch 10 TIOB pin	24	19	16	F6
	TIOB10_1		129	105	-	J14
	TIOB10_2		20	-	-	-
Base Timer 11	TIOA11_0	Base Timer ch 11 \emptyset TIOA pin	5	5	5	D5
	TIOA11_1		138	112	-	G13
	TIOA11_2		33	-	-	-
	TIOB11_0	Base Timer ch 11 TIOB pin	25	20	17	G2
	TIOB11_1		139	113	-	F14
	TIOB11_2		51	41	-	L2
Base Timer 12	TIOA12_0	Base Timer ch 12 TIOA pin	6	6	6	D2
	TIOA12_1		140	114	-	G12
	TIOA12_2		52	42	-	L3
	TIOB12_0	Base Timer ch 12 TIOB pin	30	21	18	G3
	TIOB12_1		141	115	-	G11
	TIOB12_2		53	43	-	M2
Base Timer 13	TIOA13_0	Base Timer ch 13 TIOA pin	7	7	7	D1
	TIOA13_1		154	124	100	E12
	TIOA13_2		34	24	-	G6
	TIOB13_0	Base Timer ch 13 TIOB pin	31	22	19	G4
	TIOB13_1		155	125	101	E13
	TIOB13_2		35	25	-	H4

Module	Pin Name	Function	Pin Number			
			LQFP 216	LQFP 176	LQFP 144	LBE 192
Base Timer 14	TIOA14_0	Base Timer ch 14 TIOA pin	183	151	121	D8
	TIOA14_1		89	74	-	M9
	TIOA14_2		204	-	-	-
	TIOB14_0	Base Timer ch 14 TIOB pin	182	150	120	C8
	TIOB14_1		90	75	-	L9
	TIOB14_2		203	-	-	-
Base Timer 15	TIOA15_0	Base Timer ch 15 TIOA pin	187	155	125	B7
	TIOA15_1		78	63	-	K5
	TIOA15_2		206	-	-	-
	TIOB15_0	Base timer ch 15 TIOB pin	186	154	124	F8
	TIOB15_1		79	64	-	K6
	TIOB15_2		205	-	-	-
Debugger	SWCLK	Serial wire debug interface clock input pin	165	135	111	A12
	SWDIO	Serial wire debug interface data input/output pin	167	137	113	B12
	SWO	Serial wire viewer output pin	168	138	114	B11
	TCK	J-TAG test clock input pin	165	135	111	A12
	TDI	J-TAG test data input pin	166	136	112	C12
	TDO	J-TAG debug data output pin	168	138	114	B11
	TMS	J-TAG test mode state input/output pin	167	137	113	B12
	TRACECLK	Trace CLK output pin of ETM/HTM	131	107	87	H12
	TRACED0	Trace data output pin of ETM/ Trace data output pin of HTM	132	108	88	H14
	TRACED1		133	109	89	G14
	TRACED2		134	110	90	H13
	TRACED3	Trace data output pin of HTM	135	111	91	H11
	TRACED4		138	112	-	G13
	TRACED5		139	113	-	F14
	TRACED6		140	114	-	G12
	TRACED7		141	115	-	G11
	TRACED8		119	-	-	-
	TRACED9		120	-	-	-
	TRACED10		121	-	-	-
	TRACED11		122	-	-	-
	TRACED12		148	-	-	-
	TRACED13		149	-	-	-
	TRACED14		150	-	-	-
TRACED15	151	-	-	-		
TRSTX	J-TAG test reset Input pin	164	134	110	B13	

Module	Pin Name	Function	Pin Number			
			LQFP 216	LQFP 176	LQFP 144	LBE 192
External bus	MAD00_0	External bus interface address bus	81	66	56	J6
	MAD01_0		82	67	57	L8
	MAD02_0		83	68	58	K8
	MAD03_0		84	69	59	J8
	MAD04_0		91	76	60	K9
	MAD05_0		92	77	61	P10
	MAD06_0		93	78	62	N10
	MAD07_0		96	79	63	L10
	MAD08_0		97	80	64	K10
	MAD09_0		98	81	65	M10
	MAD10_0		142	116	92	G10
	MAD11_0		143	117	93	G9
	MAD12_0		144	118	94	F10
	MAD13_0		145	119	95	F11
	MAD14_0		146	120	96	F12
	MAD15_0		147	121	97	F13
	MAD16_0		152	122	98	E10
	MAD17_0		153	123	99	E11
	MAD18_0		154	124	100	E12
	MAD19_0		50	40	35	L1
	MAD20_0		49	39	34	K4
	MAD21_0		48	38	33	K3
	MAD22_0		47	37	32	K2
	MAD23_0		46	36	31	K1
	MAD24_0	45	35	30	J2	
	MCSX0_0	External bus interface chip select output pin	71	56	48	M5
	MCSX1_0		70	55	47	L5
	MCSX2_0		61	51	43	N4
	MCSX3_0		60	50	42	M4
	MCSX4_0		59	49	41	L4
	MCSX5_0		58	48	40	M3
	MCSX6_0		57	47	39	N3
MCSX7_0	56		46	38	N2	
MCSX8_0	88		73	-	P9	

Module	Pin Name	Function	Pin Number			
			LQFP 216	LQFP 176	LQFP 144	LBE 192
External bus	MADATA00_0	External bus interface data bus (address/data multiplex bus)	2	2	2	B2
	MADATA01_0		3	3	3	C2
	MADATA02_0		4	4	4	C3
	MADATA03_0		5	5	5	D5
	MADATA04_0		6	6	6	D2
	MADATA05_0		7	7	7	D1
	MADATA06_0		8	8	8	D3
	MADATA07_0		9	9	9	D4
	MADATA08_0		14	13	10	E5
	MADATA09_0		15	14	11	F1
	MADATA10_0		16	15	12	F2
	MADATA11_0		17	16	13	F3
	MADATA12_0		18	17	14	F4
	MADATA13_0		23	18	15	F5
	MADATA14_0		24	19	16	F6
	MADATA15_0		25	20	17	G2
	MADATA16_0		10	-	-	-
	MADATA17_0		11	-	-	-
	MADATA18_0		12	-	-	-
	MADATA19_0		13	-	-	-
	MADATA20_0		19	-	-	-
	MADATA21_0		20	-	-	-
	MADATA22_0		21	-	-	-
	MADATA23_0		22	-	-	-
	MADATA24_0		26	-	-	-
	MADATA25_0	27	-	-	-	
	MADATA26_0	28	-	-	-	
	MADATA27_0	29	-	-	-	
	MADATA28_0	33	-	-	-	
	MADATA29_0	51	-	-	-	
	MADATA30_0	52	-	-	-	
	MADATA31_0	53	-	-	-	
	MDQM0_0	External bus interface byte mask signal output pin	30	21	18	G3
MDQM1_0	31		22	19	G4	
MDQM2_0	34		-	-	-	
MDQM3_0	35		-	-	-	
MALE_0	External bus interface address latch enable output signal for multiplex	211	171	139	C4	
MRDY_0	External bus interface external RDY input signal	80	65	55	L6	
MCLKOUT_0	External bus interface external clock output pin	32	23	20	G5	

Module	Pin Name	Function	Pin Number			
			LQFP 216	LQFP 176	LQFP 144	LBE 192
External bus	MNALE_0	External bus interface ALE signal to control NAND flash output pin	47	37	32	K2
	MNCLE_0	External bus interface CLE signal to control NAND flash output pin	48	38	33	K3
	MNREX_0	External bus interface read enable signal to control NAND flash	50	40	35	L1
	MNWEX_0	External bus interface write enable signal to control NAND flash	49	39	34	K4
	MOEX_0	External bus interface read enable signal for SRAM	209	169	137	C5
	MWEX_0	External bus interface write enable signal for SRAM	210	170	138	B4
	MSDCLK_0	SDRAM interface SDRAM clock output pin	90	75	-	L9
	MSDCKE_0	SDRAM interface SDRAM clock enable pin	89	74	-	M9
	MRASX_0	SDRAM interface SDRAM column active strobe pin	85	70	-	N8
	MCASX_0	SDRAM interface SDRAM row active strobe pin	86	71	-	M8
	MSDWEX_0	SDRAM interface SDRAM write enable pin	87	72	-	N9
External interrupt	INT00_0	External interrupt request 00 input pin	2	2	2	B2
	INT00_1		38	28	23	H3
	INT00_2		19	-	-	-
	INT01_0	External interrupt request 01 input pin	7	7	7	D1
	INT01_1		41	31	26	H6
	INT01_2		51	41	-	L2
	INT02_0	External interrupt request 02 input pin	14	13	10	E5
	INT02_1		42	32	27	J5
	INT02_2		26	-	-	-
	INT03_0	External interrupt request 03 input pin	17	16	13	F3
	INT03_1		43	33	28	J4
	INT03_2		34	24	-	G6
	INT04_0	External interrupt request 04 input pin	59	49	41	L4
	INT04_1		100	83	67	M11
	INT04_2		65	-	-	-
	INT05_0	External interrupt request 05 input pin	70	55	47	L5
	INT05_1		86	71	-	M8
INT05_2	68		-	-	-	

Module	Pin Name	Function	Pin Number			
			LQFP 216	LQFP 176	LQFP 144	LBE 192
External interrupt	INT06_0	External interrupt request 06 input pin	80	65	55	L6
	INT06_1		87	72	-	N9
	INT06_2		103	-	-	-
	INT07_0	External interrupt request 07 input pin	82	67	57	L8
	INT07_1		88	73	-	P9
	INT07_2		102	-	-	-
	INT08_0	External interrupt request 08 input pin	114	94	78	L11
	INT08_1		127	103	-	J9
	INT08_2		119	-	-	-
	INT09_0	External interrupt request 09 input pin	123	99	83	J13
	INT09_1		128	104	-	H10
	INT09_2		120	-	-	-
	INT10_0	External interrupt request 10 input pin	130	106	86	H9
	INT10_1		138	112	-	G13
	INT10_2		149	-	-	-
	INT11_0	External interrupt request 11 input pin	133	109	89	G14
	INT11_1		139	113	-	F14
	INT11_2		151	-	-	-
	INT12_0	External interrupt request 12 input pin	194	162	132	E7
	INT12_1		169	139	-	C11
	INT12_2		175	-	-	-
	INT13_0	External interrupt request 13 input pin	184	152	122	E8
	INT13_1		170	140	-	D11
	INT13_2		176	-	-	-
	INT14_0	External interrupt request 14 input pin	192	160	130	A6
	INT14_1		171	141	-	B10
	INT14_2		201	-	-	-
	INT15_0	External interrupt request 15 input pin	193	161	131	D7
	INT15_1		172	142	-	C10
	INT15_2		206	-	-	-
	INT16_0	External interrupt request 16 input pin	25	20	17	G2
	INT16_1		45	35	30	J2
INT17_0	External interrupt request 17 input pin	30	21	18	G3	
INT17_1		46	36	31	K1	
INT18_0	External interrupt request 18 input pin	31	22	19	G4	
INT18_1		47	37	32	K2	
INT19_0	External interrupt request 19 input pin	36	26	21	H2	
INT19_1		48	38	33	K3	
INT20_0	External interrupt request 20 input pin	91	76	60	K9	
INT20_1		89	74	-	M9	

Module	Pin Name	Function	Pin Number			
			LQFP 216	LQFP 176	LQFP 144	LBE 192
External interrupt	INT21_0	External interrupt request 21 input pin	96	79	63	L10
	INT21_1		90	75	-	L9
	INT22_0	External interrupt request 22 input pin	99	82	66	N11
	INT22_1		78	63	-	K5
	INT23_0	External interrupt request 23 input pin	56	46	38	N2
	INT23_1		79	64	-	K6
	INT24_0	External interrupt request 24 input pin	147	121	97	F13
	INT24_1		131	107	87	H12
	INT25_0	External interrupt request 25 input pin	153	123	99	E11
	INT25_1		117	97	81	K14
	INT26_0	External interrupt request 26 input pin	156	126	102	D12
	INT26_1		142	116	92	G10
	INT27_0	External interrupt request 27 input pin	157	127	103	D13
	INT27_1		143	117	93	G9
	INT28_0	External interrupt request 28 input pin	190	158	128	A7
	INT28_1		207	167	-	E6
	INT29_0	External interrupt request 29 input pin	198	166	136	D6
	INT29_1		208	168	-	B5
	INT30_0	External interrupt request 30 input pin	209	169	137	C5
	INT30_1		195	163	133	F7
INT31_0	External interrupt request 31 input pin	212	172	140	B3	
INT31_1		196	164	134	B6	
	NMIX	Non-maskable interrupt input pin	158	128	104	C13

Module	Pin Name	Function	Pin Number			
			LQFP 216	LQFP 176	LQFP 144	LBE 192
GPIO	P00	General-purpose I/O port 0	164	134	110	B13
	P01		165	135	111	A12
	P02		166	136	112	C12
	P03		167	137	113	B12
	P04		168	138	114	B11
	P08		30	21	18	G3
	P09		31	22	19	G4
	P0A		32	23	20	G5
	P10	General-purpose I/O port 1	114	94	78	L11
	P11		115	95	79	K13
	P12		116	96	80	K12
	P13		117	97	81	K14
	P14		118	98	82	K11
	P15		123	99	83	J13
	P16		124	100	84	J12
	P17		125	101	85	J11
	P18		130	106	86	H9
	P19		131	107	87	H12
	P1A		132	108	88	H14
	P1B		133	109	89	G14
	P1C	134	110	90	H13	
	P1D	135	111	91	H11	
	P1E	142	116	92	G10	
	P1F	143	117	93	G9	
	P20	General-purpose I/O port 2	158	128	104	C13
	P21		157	127	103	D13
	P22		156	126	102	D12
	P23		155	125	101	E13
	P24		154	124	100	E12
	P25		153	123	99	E11
P26	152		122	98	E10	
P27	147		121	97	F13	
P28	146		120	96	F12	
P29	145		119	95	F11	
P2A	144	118	94	F10		

Module	Pin Name	Function	Pin Number			
			LQFP 216	LQFP 176	LQFP 144	LBE 192
GPIO	P30	General-purpose I/O port 3	34	24	-	G6
	P31		35	25	-	H4
	P32		36	26	21	H2
	P33		37	27	22	J1
	P34		38	28	23	H3
	P35		41	31	26	H6
	P36		42	32	27	J5
	P37		43	33	28	J4
	P38		44	34	29	J3
	P39		45	35	30	J2
	P3A		46	36	31	K1
	P3B		47	37	32	K2
	P3C		48	38	33	K3
	P3D		49	39	34	K4
	P3E		50	40	35	L1
	P40	General-purpose I/O port 4	56	46	38	N2
	P41		57	47	39	N3
	P42		58	48	40	M3
	P43		59	49	41	L4
	P44		60	50	42	M4
	P45		61	51	43	N4
	P46		73	58	50	P5
	P47		74	59	51	P6
	P48		76	61	53	N6
	P49		77	62	54	M6
	P4A		65	-	-	-
	P4B		66	-	-	-
	P4C		67	-	-	-
	P4D		68	-	-	-
	P4E		69	-	-	-

Module	Pin Name	Function	Pin Number			
			LQFP 216	LQFP 176	LQFP 144	LBE 192
GPIO	P50	General-purpose I/O port 5	10	10	-	E2
	P51		11	11	-	E3
	P52		12	12	-	E4
	P53		13	-	-	-
	P54		19	-	-	-
	P55		20	-	-	-
	P56		21	-	-	-
	P57		22	-	-	-
	P58		26	-	-	-
	P59		27	-	-	-
	P5A		28	-	-	-
	P5B		29	-	-	-
	P5C		33	-	-	-
	P5D		51	41	-	L2
	P5E		52	42	-	L3
	P5F		53	43	-	M2
	P60	General-purpose I/O port 6	212	172	140	B3
	P61		211	171	139	C4
	P62		210	170	138	B4
	P63		209	169	137	C5
	P64		208	168	-	B5
	P65		207	167	-	E6
	P66		206	-	-	-
	P67		205	-	-	-
	P68		204	-	-	-
	P69		203	-	-	-
	P6A		202	-	-	-
	P6B		201	-	-	-
P6C	200	-	-	-		
P6D	199	-	-	-		
P6E	198	166	136	D6		

Module	Pin Name	Function	Pin Number			
			LQFP 216	LQFP 176	LQFP 144	LBE 192
GPIO	P70	General-purpose I/O port 7	80	65	55	L6
	P71		81	66	56	J6
	P72		82	67	57	L8
	P73		83	68	58	K8
	P74		84	69	59	J8
	P75		91	76	60	K9
	P76		92	77	61	P10
	P77		93	78	62	N10
	P78		96	79	63	L10
	P79		97	80	64	K10
	P7A		98	81	65	M10
	P7B		99	82	66	N11
	P7C		100	83	67	M11
	P7D		70	55	47	L5
	P7E		71	56	48	M5
	P80	General-purpose I/O port 8	214	174	142	A3
	P81		215	175	143	A2
	P82		160	130	106	D14
	P83		161	131	107	C14
	P90	General-purpose I/O port 9	169	139	-	C11
	P91		170	140	-	D11
	P92		171	141	-	B10
	P93		172	142	-	C10
	P94		173	143	-	D10
	P95		174	144	-	B9
	P96		175	-	-	-
	P97		176	-	-	-

Module	Pin Name	Function	Pin Number			
			LQFP 216	LQFP 176	LQFP 144	LBE 192
GPIO	PA0	General-purpose I/O port A	2	2	2	B2
	PA1		3	3	3	C2
	PA2		4	4	4	C3
	PA3		5	5	5	D5
	PA4		6	6	6	D2
	PA5		7	7	7	D1
	PA6		8	8	8	D3
	PA7		9	9	9	D4
	PA8		14	13	10	E5
	PA9		15	14	11	F1
	PAA		16	15	12	F2
	PAB		17	16	13	F3
	PAC		18	17	14	F4
	PAD		23	18	15	F5
	PAE		24	19	16	F6
	PAF		25	20	17	G2
	PB0	General-purpose I/O port B	126	102	-	J10
	PB1		127	103	-	J9
	PB2		128	104	-	H10
	PB3		129	105	-	J14
	PB4		138	112	-	G13
	PB5		139	113	-	F14
	PB6		140	114	-	G12
	PB7		141	115	-	G11
	PB8		119	-	-	-
	PB9		120	-	-	-
	PBA		121	-	-	-
	PBB		122	-	-	-
	PBC		148	-	-	-
	PBD		149	-	-	-
	PBE		150	-	-	-
	PBF		151	-	-	-

Module	Pin Name	Function	Pin Number			
			LQFP 216	LQFP 176	LQFP 144	LBE 192
GPIO	PC0	General-purpose I/O port C	177	145	115	C9
	PC1		178	146	116	B8
	PC2		179	147	117	D9
	PC3		180	148	118	E9
	PC4		181	149	119	F9
	PC5		182	150	120	C8
	PC6		183	151	121	D8
	PC7		184	152	122	E8
	PC8		185	153	123	A10
	PC9		186	154	124	F8
	PCA		187	155	125	B7
	PCB		190	158	128	A7
	PCC		191	159	129	C7
	PCD		192	160	130	A6
	PCE		193	161	131	D7
	PCF		194	162	132	E7
	PD0	General-purpose I/O port D	195	163	133	F7
	PD1		196	164	134	B6
	PD2		197	165	135	C6
	PE0	General-purpose I/O port E	104	84	68	N13
	PE2		106	86	70	P12
	PE3		107	87	71	P13
	PF0	General-purpose I/O port F	78	63	-	K5
	PF1		79	64	-	K6
	PF2		85	70	-	N8
	PF3		86	71	-	M8
	PF4		87	72	-	N9
	PF5		88	73	-	P9
	PF6		89	74	-	M9
	PF7		91	75	-	L9
PF8	94		-	-	-	
PF9	95		-	-	-	
PFA	101		-	-	-	
PFB	102		-	-	-	
PFC	103		-	-	-	

Module	Pin Name	Function	Pin Number			
			LQFP 216	LQFP 176	LQFP 144	LBE 192
Multi-Function Serial 0	SIN0_0	Multi-function serial interface ch 0 input pin	157	127	103	D13
	SIN0_1		151	-	-	-
	SOT0_0 (SDA0_0)	Multi-function serial interface ch 0 output pin	156	126	102	D12
	SOT0_1 (SDA0_1)	This pin operates as SOT0 when it is used in a UART/CSIO/LIN (operation modes 0 to 3) and as SDA0 when it is used in an I ² C (operation mode 4).	150	-	-	-
	SCK0_0 (SCL0_0)	Multi-function serial interface ch 0 clock I/O pin	155	125	101	E13
	SCK0_1 (SCL0_1)	This pin operates as SCK0 when it is used in a CSIO (operation mode 2) and as SCL0 when it is used in an I ² C (operation mode 4)	149	-	-	-
Multi-Function Serial 1	SIN1_0	Multi-function serial interface ch 1 input pin	7	7	7	D1
	SIN1_1		80	65	55	L6
	SOT1_0 (SDA1_0)	Multi-function serial interface ch 1 output pin	8	8	8	D3
	SOT1_1 (SDA1_1)	This pin operates as SOT1 when it is used in a UART/CSIO/LIN (operation modes 0 to 3) and as SDA1 when it is used in an I ² C (operation mode 4).	81	66	56	J6
	SCK1_0 (SCL1_0)	Multi-function serial interface ch 1 clock I/O pin	9	9	9	D4
	SCK1_1 (SCL1_1)	This pin operates as SCK1 when it is used in a CSIO (operation mode 2) and as SCL1 when it is used in an I ² C (operation mode 4).	70	55	47	L5
Multi-Function Serial 2	SIN2_0	Multi-function serial interface ch 2 input pin	130	106	86	H9
	SIN2_1		45	35	30	J2
	SOT2_0 (SDA2_0)	Multi-function serial interface ch 2 output pin	131	107	87	H12
	SOT2_1 (SDA2_1)	This pin operates as SOT2 when it is used in a UART/CSIO/LIN (operation modes 0 to 3) and as SDA2 when it is used in an I ² C (operation mode 4).	46	36	31	K1
	SCK2_0 (SCL2_0)	Multi-function serial interface ch 2 clock I/O pin	132	108	88	H14
	SCK2_1 (SCL2_1)	This pin operates as SCK2 when it is used in a CSIO (operation mode 2) and as SCL2 when it is used in an I ² C (operation mode 4).	47	37	32	K2

Module	Pin Name	Function	Pin Number			
			LQFP 216	LQFP 176	LQFP 144	LBE 192
Multi-Function Serial 3	SIN3_0	Multi-function serial interface ch 3 input pin	25	20	17	G2
	SIN3_1		56	46	38	N2
	SOT3_0 (SDA3_0)	Multi-function serial interface ch 3 output pin	24	19	16	F6
	SOT3_1 (SDA3_1)	This pin operates as SOT3 when it is used in a UART/CSIO/LIN (operation modes 0 to 3) and as SDA3 when it is used in an I ² C (operation mode 4).	57	47	39	N3
	SCK3_0 (SCL3_0)	Multi-function serial interface ch 3 clock I/O pin	23	18	15	F5
	SCK3_1 (SCL3_1)	This pin operates as SCK3 when it is used in a CSIO (operation modes 2) and as SCL3 when it is used in an I ² C (operation mode 4).	58	48	40	M3
Multi-Function Serial 4	SIN4_0	Multi-function serial interface ch 4 input pin	212	172	140	B3
	SIN4_1		193	161	131	D7
	SOT4_0 (SDA4_0)	Multi-function serial interface ch 4 output pin	211	171	139	C4
	SOT4_1 (SDA4_1)	This pin operates as SOT4 when it is used in a UART/CSIO/LIN (operation modes 0 to 3) and as SDA4 when it is used in an I ² C (operation mode 4).	192	160	130	A6
	SCK4_0 (SCL4_0)	Multi-function serial interface ch 4 clock I/O pin	210	170	138	B4
	SCK4_1 (SCL4_1)	This pin operates as SCK4 when it is used in a CSIO (operation mode 2) and as SCL4 when it is used in an I ² C (operation mode 4).	198	166	136	D6
	CTS4_0	Multi-function serial interface ch 4 CTS input pin	208	168	-	B5
	CTS4_1		197	165	135	C6
	RTS4_0	Multi-function serial interface ch 4 RTS output pin	209	169	137	C5
	RTS4_1		194	162	132	E7

Module	Pin Name	Function	Pin Number			
			LQFP 216	LQFP 176	LQFP 144	LBE 192
Multi-Function Serial 5	SIN5_0	Multi-function serial interface ch 5 input pin	147	121	97	F13
	SIN5_1		170	140	-	D11
	SOT5_0 (SDA5_0)	Multi-function serial interface ch 5 output pin	146	120	96	F12
	SOT5_1 (SDA5_1)	This pin operates as SOT5 when it is used in a UART/CSIO/LIN (operation modes 0 to 3) and as SDA5 when it is used in an I ² C (operation mode 4).	171	141	-	B10
	SCK5_0 (SCL5_0)	Multi-function serial interface ch 5 clock I/O pin	145	119	95	F11
	SCK5_1 (SCL5_1)	This pin operates as SCK5 when it is used in a CSIO (operation mode 2) and as SCL5 when it is used in an I ² C (operation mode 4).	172	142	-	C10
	CTS5_0	Multi-function serial interface ch 5 CTS input pin	144	118	94	F10
	CTS5_1		173	143	-	D10
	RTS5_0	Multi-function serial interface ch 5 RTS output pin	143	117	93	G9
	RTS5_1		174	144	-	B9
Multi-Function Serial 6	SIN6_0	Multi-function serial interface ch 6 input pin	96	79	63	L10
	SIN6_1		117	97	81	K14
	SOT6_0 (SDA6_0)	Multi-function serial interface ch 6 output pin	97	80	64	K10
	SOT6_1 (SDA6_1)	This pin operates as SOT6 when it is used in a UART/CSIO/LIN (operation modes 0 to 3) and as SDA6 when it is used in an I ² C (operation mode 4).	118	98	82	K11
	SCK6_0 (SCL6_0)	Multi-function serial interface ch 6 clock I/O pin	98	81	65	M10
	SCK6_1 (SCL6_1)	This pin operates as SCK6 when it is used in a CSIO (operation mode 2) and as SCL6 when it is used in an I ² C (operation mode 4).	126	102	-	J10
	SCS60_0	Multi-function serial interface ch 6 chip select 0 input/output pin	99	82	66	N11
	SCS60_1		127	103	-	J9
	SCS61_0	Multi-function serial interface ch 6 chip select1 input/output pin	100	83	67	M11
	SCS61_1		128	104	-	H10
	SCS62_0	Multi-function serial interface ch 6 chip select2 input/output pin	79	64	-	K6
	SCS62_1		129	105	-	J14
	SCS63_0	Multi-function serial interface ch 6 chip select3 input/output pin	78	63	-	K5
	SCS63_1		119	-	-	-

Module	Pin Name	Function	Pin Number			
			LQFP 216	LQFP 176	LQFP 144	LBE 192
Multi-Function Serial 7	SIN7_0	Multi-function serial interface ch 7 input pin	14	13	10	E5
	SIN7_1		103	-	-	-
	SOT7_0 (SDA7_0)	Multi-function serial interface ch 7 output pin	15	14	11	F1
	SOT7_1 (SDA7_1)	This pin operates as SOT7 when it is used in a UART/CSIO/LIN (operation modes 0 to 3) and as SDA7 when it is used in an I ² C (operation mode 4).	102	-	-	-
	SCK7_0 (SCL7_0)	Multi-function serial interface ch 7 clock I/O pin	16	15	12	F2
	SCK7_1 (SCL7_1)	This pin operates as SCK7 when it is used in a CSIO (operation mode 2) and as SCL7 when it is used in an I ² C (operation mode 4).	101	-	-	-
	SCS70_0	Multi-function serial interface ch 7 chip select 0 input/output pin	17	16	13	F3
	SCS70_1		94	-	-	-
	SCS71_0	Multi-function serial interface ch 7 chip select 1 input/output pin	18	17	14	F4
	SCS71_1		95	-	-	-
	SCS72_0	Multi-function serial interface ch 7 chip select 2 input/output pin	10	10	-	E2
	SCS72_1		68	-	-	-
	SCS73_0	Multi-function serial interface ch 7 chip select 3 input/output pin	11	11	-	E3
	SCS73_1		69	-	-	-
Multi-Function Serial 8	SIN8_0	Multi-function serial interface ch 8 input pin	91	76	60	K9
	SIN8_1		138	112	-	G13
	SOT8_0 (SDA8_0)	Multi-function serial interface ch 8 output pin	92	77	61	P10
	SOT8_1 (SDA8_1)	This pin operates as SOT8 when it is used in a UART/CSIO/LIN (operation modes 0 to 3) and as SDA8 when it is used in an I ² C (operation mode 4).	139	113	-	F14
	SCK8_0 (SCL8_0)	Multi-function serial interface ch 8 clock I/O pin	93	78	62	N10
	SCK8_1 (SCL8_1)	This pin operates as SCK8 when it is used in a CSIO (operation mode 2) and as SCL8 when it is used in an I ² C (operation mode 4).	140	114	-	G12

Module	Pin Name	Function	Pin Number			
			LQFP 216	LQFP 176	LQFP 144	LBE 192
Multi-Function Serial 9	SIN9_0	Multi-function serial interface ch 9 input pin	82	67	57	L8
	SIN9_1		120	-	-	-
	SOT9_0 (SDA9_0)	Multi-function serial interface ch 9 output pin	83	68	58	K8
	SOT9_1 (SDA9_1)	This pin operates as SOT9 when it is used in a UART/CSIO/LIN (operation modes 0 to 3) and as SDA9 when it is used in an I ² C (operation mode 4).	121	-	-	-
	SCK9_0 (SCL9_0)	Multi-function serial interface ch 9 clock I/O pin	84	69	59	J8
	SCK9_1 (SCL9_1)	This pin operates as SCK9 when it is used in a CSIO (operation mode 2) and as SCL9 when it is used in an I ² C (operation mode 4).	122	-	-	-
Multi-Function Serial 10	SIN10_0	Multi-function serial interface ch 10 input pin	114	94	78	L11
	SIN10_1		51	41	-	L2
	SOT10_0 (SDA10_0)	Multi-function serial interface ch 10 output pin	115	95	79	K13
	SOT10_1 (SDA10_1)	This pin operates as SOT10 when it is used in a UART/CSIO/LIN (operation modes 0 to 3) and as SDA10 when it is used in an I ² C (operation mode 4).	52	42	-	L3
	SCK10_0 (SCL10_0)	Multi-function serial interface ch 10 clock I/O pin	116	96	80	K12
	SCK10_1 (SCL10_1)	This pin operates as SCK10 when it is used in a CSIO (operation mode 2) and as SCL10 when it is used in an I ² C (operation mode 4).	53	43	-	M2
Multi-Function Serial 11	SIN11_0	Multi-function serial interface ch 11 input pin	123	99	83	J13
	SIN11_1		26	-	-	-
	SOT11_0 (SDA11_0)	Multi-function serial interface ch 11 output pin	124	100	84	J12
	SOT11_1 (SDA11_1)	This pin operates as SOT11 when it is used in a UART/CSIO/LIN (operation modes 0 to 3) and as SDA11 when it is used in an I ² C (operation mode 4).	27	-	-	-
	SCK11_0 (SCL11_0)	Multi-function serial interface ch 11 clock I/O pin	125	101	85	J11
	SCK11_1 (SCL11_1)	This pin operates as SCK11 when it is used in a CSIO (operation mode 2) and as SCL11 when it is used in an I ² C (operation mode 4).	28	-	-	-

Module	Pin Name	Function	Pin Number			
			LQFP 216	LQFP 176	LQFP 144	LBE 192
Multi-Function Serial 12	SIN12_0	Multi-function serial interface ch 12 input pin	133	109	89	G14
	SIN12_1		65	-	-	-
	SOT12_0 (SDA12_0)	Multi-function serial interface ch 12 output pin	134	110	90	H13
	SOT12_1 (SDA12_1)	This pin operates as SOT12 when it is used in a UART/CSIO/LIN (operation modes 0 to 3) and as SDA12 when it is used in an I ² C (operation mode 4).	66	-	-	-
	SCK12_0 (SCL12_0)	Multi-function serial interface ch 12 clock I/O pin	135	111	91	H11
	SCK12_1 (SCL12_1)	This pin operates as SCK12 when it is used in a CSIO (operation mode 2) and as SCL12 when it is used in an I ² C (operation mode 4).	67	-	-	-
Multi-Function Serial 13	SIN13_0	Multi-function serial interface ch 13 input pin	48	38	33	K3
	SIN13_1		206	-	-	-
	SOT13_0 (SDA13_0)	Multi-function serial interface ch 13 output pin	49	39	34	K4
	SOT13_1 (SDA13_1)	This pin operates as SOT13 when it is used in a UART/CSIO/LIN (operation modes 0 to 3) and as SDA13 when it is used in an I ² C (operation mode 4).	205	-	-	-
	SCK13_0 (SCL13_0)	Multi-function serial interface ch 13 clock I/O pin	50	40	35	L1
	SCK13_1 (SCL13_1)	This pin operates as SCK13 when it is used in a CSIO (operation mode 2) and as SCL13 when it is used in an I ² C (operation mode 4).	204	-	-	-
Multi-Function Serial 14	SIN14_0	Multi-function serial interface ch 14 input pin	30	21	18	G3
	SIN14_1		201	-	-	-
	SOT14_0 (SDA14_0)	Multi-function serial interface ch 14 output pin	31	22	19	G4
	SOT14_1 (SDA14_1)	This pin operates as SOT14 when it is used in a UART/CSIO/LIN (operation modes 0 to 3) and as SDA14 when it is used in an I ² C (operation mode 4).	200	-	-	-
	SCK14_0 (SCL14_0)	Multi-function serial interface ch 14 clock I/O pin	32	23	20	G5
	SCK14_1 (SCL14_1)	This pin operates as SCK14 when it is used in a CSIO (operation mode 2) and as SCL14 when it is used in an I ² C (operation mode 4).	199	-	-	-

Module	Pin Name	Function	Pin Number			
			LQFP 216	LQFP 176	LQFP 144	LBE 192
Multi-Function Serial 15	SIN15_0	Multi-function serial interface ch 15 input pin	59	49	41	L4
	SIN15_1		19	-	-	-
	SOT15_0 (SDA15_0)	Multi-function serial interface ch 15 output pin	60	50	42	M4
	SOT15_1 (SDA15_1)	This pin operates as SOT15 when it is used in a UART/CSIO/LIN (operation modes 0 to 3) and as SDA15 when it is used in an I ² C (operation mode 4).	20	-	-	-
	SCK15_0 (SCL15_0)	Multi-function serial interface ch 15 clock I/O pin	61	51	43	N4
	SCK15_1 (SCL15_1)	This pin operates as SCK15 when it is used in a CSIO (operation mode 2) and as SCL15 when it is used in an I ² C (operation mode 4).	21	-	-	-

Module	Pin Name	Function	Pin Number				
			LQFP 216	LQFP 176	LQFP 144	LBE 192	
Multi-Function Timer 0	DTTI0X_0	Input signal controlling waveform generator outputs RTO00 to RTO05 of Multi-Function Timer 0.	44	34	29	J3	
	DTTI0X_1		21	-	-	-	
	FRCK0_0	16-bit free-run timer ch 0 external clock input pin	37	27	22	J1	
	FRCK0_1		29	-	-	-	
	IC00_0	16-bit input capture input pin of Multi-Function Timer 0. ICxx describes channel number.	43	33	28	J4	
	IC00_1		22	-	-	-	
	IC01_0		42	32	27	J5	
	IC01_1		26	-	-	-	
	IC02_0		41	31	26	H6	
	IC02_1		27	-	-	-	
	IC03_0		38	28	23	H3	
	IC03_1		28	-	-	-	
	RTO00_0 (PPG00_0)		Waveform generator output pin of Multi-Function Timer 0.	45	35	30	J2
	RTO00_1 (PPG00_1)		This pin operates as PPG00 when it is used in PPG0 output modes.	10	10	-	E2
	RTO01_0 (PPG00_0)	Waveform generator output pin of Multi-Function Timer 0.	46	36	31	K1	
	RTO01_1 (PPG00_1)	This pin operates as PPG00 when it is used in PPG0 output modes.	11	11	-	E3	
	RTO02_0 (PPG02_0)	Waveform generator output pin of Multi-Function Timer 0.	47	37	32	K2	
	RTO02_1 (PPG02_1)	This pin operates as PPG02 when it is used in PPG0 output modes.	12	12	-	E4	
	RTO03_0 (PPG02_0)	Waveform generator output pin of Multi-Function Timer 0.	48	38	33	K3	
	RTO03_1 (PPG02_1)	This pin operates as PPG02 when it is used in PPG0 output modes.	13	-	-	-	
	RTO04_0 (PPG04_0)	Waveform generator output pin of Multi-Function Timer 0.	49	39	34	K4	
	RTO04_1 (PPG04_1)	This pin operates as PPG04 when it is used in PPG0 output modes.	19	-	-	-	
	RTO05_0 (PPG04_0)	Waveform generator output pin of Multi-Function Timer 0.	50	40	35	L1	
	RTO05_1 (PPG04_1)	This pin operates as PPG04 when it is used in PPG0 output modes.	20	-	-	-	

Module	Pin Name	Function	Pin Number				
			LQFP 216	LQFP 176	LQFP 144	LBE 192	
Multi-Function Timer 1	DTTI1X_0	Input signal controlling waveform generator outputs RTO10 to RTO15 of Multi-Function Timer 1.	70	55	47	L5	
	DTTI1X_1		94	-	-	-	
	FRCK1_0	16-bit free-run timer ch 1 external clock input pin	71	56	48	M5	
	FRCK1_1		78	63	-	K5	
	IC10_0	16-bit input capture input pin of Multi-Function Timer 1. ICxx describes channel number.	96	79	63	L10	
	IC10_1		95	-	-	-	
	IC11_0		97	80	64	K10	
	IC11_1		101	-	-	-	
	IC12_0		98	81	65	M10	
	IC12_1		102	-	-	-	
	IC13_0		99	82	66	N11	
	IC13_1		103	-	-	-	
	RTO10_0 (PPG10_0)		Waveform generator output pin of Multi-Function Timer 1.	56	46	38	N2
	RTO10_1 (PPG10_1)		This pin operates as PPG10 when it is used in PPG1 output modes.	85	70	-	N8
	RTO11_0 (PPG10_0)	Waveform generator output pin of Multi-Function Timer 1.	57	47	39	N3	
	RTO11_1 (PPG10_1)	This pin operates as PPG10 when it is used in PPG1 output modes.	86	71	-	M8	
	RTO12_0 (PPG12_0)	Waveform generator output pin of Multi-Function Timer 1.	58	48	40	M3	
	RTO12_1 (PPG12_1)	This pin operates as PPG12 when it is used in PPG1 output modes.	87	72	-	N9	
	RTO13_0 (PPG12_0)	Waveform generator output pin of Multi-Function Timer 1.	59	49	41	L4	
	RTO13_1 (PPG12_1)	This pin operates as PPG12 when it is used in PPG1 output modes.	88	73	-	P9	
	RTO14_0 (PPG14_0)	Waveform generator output pin of Multi-Function Timer 1.	60	50	42	M4	
	RTO14_1 (PPG14_1)	This pin operates as PPG14 when it is used in PPG1 output modes.	89	74	-	M9	
	RTO15_0 (PPG14_0)	Waveform generator output pin of Multi-Function Timer 1.	61	51	43	N4	
	RTO15_1 (PPG14_1)	This pin operates as PPG14 when it is used in PPG1 output modes.	90	75	-	L9	

Module	Pin Name	Function	Pin Number				
			LQFP 216	LQFP 176	LQFP 144	LBE 192	
Multi-Function Timer 2	DTTI2X_0	Input signal controlling waveform generator outputs RTO20 to RTO25 of Multi-Function Timer 1.	8	8	8	D3	
	DTTI2X_1		202	-	-	-	
	FRCK2_0	16-bit free-run timer ch 2 external clock input pin	17	16	13	F3	
	FRCK2_1		197	165	135	C6	
	IC20_0	16-bit input capture input pin of Multi-Function Timer 2. ICxx describes channel number.	9	9	9	D4	
	IC20_1		201	-	-	-	
	IC21_0		14	13	10	E5	
	IC21_1		200	-	-	-	
	IC22_0		15	14	11	F1	
	IC22_1		199	-	-	-	
	IC23_0		16	15	12	F2	
	IC23_1		198	166	136	D6	
	RTO20_0 (PPG20_0)		Waveform generator output pin of Multi-Function Timer 2.	2	2	2	B2
	RTO20_1 (PPG20_1)		This pin operates as PPG20 when it is used in PPG2 output modes.	203	-	-	-
	RTO21_0 (PPG20_0)		Waveform generator output pin of Multi-Function Timer 2.	3	3	3	C2
	RTO21_1 (PPG20_1)	This pin operates as PPG20 when it is used in PPG2 output modes.	204	-	-	-	
	RTO22_0 (PPG22_0)	Waveform generator output pin of Multi-Function Timer 2.	4	4	4	C3	
	RTO22_1 (PPG22_1)	This pin operates as PPG22 when it is used in PPG2 output modes.	205	-	-	-	
	RTO23_0 (PPG22_0)	Waveform generator output pin of Multi-Function Timer 2.	5	5	5	D5	
	RTO23_1 (PPG22_1)	This pin operates as PPG22 when it is used in PPG2 output modes.	206	-	-	-	
	RTO24_0 (PPG24_0)	Waveform generator output pin of Multi-Function Timer 2.	6	6	6	D2	
	RTO24_1 (PPG24_1)	This pin operates as PPG24 when it is used in PPG2 output modes.	207	167	-	E6	
	RTO25_0 (PPG24_0)	Waveform generator output pin of Multi-Function Timer 2.	7	7	7	D1	
	RTO25_1 (PPG24_1)	This pin operates as PPG24 when it is used in PPG2 output modes.	208	168	-	B5	

Module	Pin Name	Function	Pin Number				
			LQFP 216	LQFP 176	LQFP 144	LBE 192	
Quadrature Position/ Revolution Counter 0	AIN0_0	QPRC ch 0 AIN input pin	56	46	38	N2	
	AIN0_1		65	-	-	-	
	AIN0_2		114	94	78	L11	
	BIN0_0	QPRC ch 0 BIN input pin	57	47	39	N3	
			BIN0_1	66	-	-	-
			BIN0_2	115	95	79	K13
	ZIN0_0	QPRC ch 0 ZIN input pin	58	48	40	M3	
			ZIN0_1	67	-	-	-
			ZIN0_2	116	96	80	K12
Quadrature Position/ Revolution Counter 1	AIN1_0	QPRC ch 1 AIN input pin	91	76	60	K9	
	AIN1_1		94	-	-	-	
	AIN1_2		123	99	83	J13	
	BIN1_0	QPRC ch 1 BIN input pin	92	77	61	P10	
			BIN1_1	45	-	-	-
			BIN1_2	124	100	84	J12
	ZIN1_0	QPRC ch 1 ZIN input pin	93	78	62	N10	
			ZIN1_1	101	-	-	-
			ZIN1_2	125	101	85	J11
Quadrature Position/ Revolution Counter 2	AIN2_0	QPRC ch 2 AIN input pin	2	2	2	B2	
	AIN2_1		32	23	20	G5	
	AIN2_2		120	-	-	-	
	BIN2_0	QPRC ch 2 BIN input pin	3	3	3	C2	
			BIN2_1	36	26	21	H2
			BIN2_2	121	-	-	-
	ZIN2_0	QPRC ch 2 ZIN input pin	4	4	4	C3	
			ZIN2_1	37	27	22	J1
			ZIN2_2	122	-	-	-
Quadrature Position/ Revolution Counter 3	AIN3_0	QPRC ch 3 AIN input pin	18	17	14	F4	
	AIN3_1		45	35	30	J2	
	AIN3_2		149	-	-	-	
	BIN3_0	QPRC ch 3 BIN input pin	23	18	15	F5	
			BIN3_1	46	36	31	K1
			BIN3_2	150	-	-	-
	ZIN3_0	QPRC ch 3 ZIN input pin	24	19	16	F6	
			ZIN3_1	47	37	32	K2
			ZIN3_2	151	-	-	-
Real-time clock	RTCCO_0	0.5 seconds pulse output pin of real-time clock	211	171	139	C4	
	RTCCO_1		33	-	-	-	
	SUBOUT_0	Sub-clock output pin	211	171	139	C4	
	SUBOUT_1		33	-	-	-	

Module	Pin Name	Function	Pin Number			
			LQFP 216	LQFP 176	LQFP 144	LBE 192
USB0	UDM0	USB ch 0 function/host D – pin	214	174	142	A3
	UDP0	USB ch 0 function/host D + pin	215	175	143	A2
	UHCONX0	USB ch 0 external pull-up control pin	211	171	139	C4
USB1	UDM1	USB ch 1 function/host D – pin	160	130	106	D14
	UDP1	USB ch 1 function/host D + pin	161	131	107	C14
	UHCONX1	USB ch 1 external pull-up control pin	155	125	101	E13
Low power consumption mode	WKUP0	Deep standby mode return signal input pin 0	158	128	104	C13
	WKUP1	Deep standby mode return signal input pin 1	14	13	10	E5
	WKUP2	Deep standby mode return signal input pin 2	70	55	47	L5
	WKUP3	Deep standby mode return signal input pin 3	212	172	140	B3
D/A converter	DA0	D/A converter ch 0 analog output pin	100	83	67	M11
	DA1	D/A converter ch 1 analog output pin	99	82	66	N11
VBAT	VREGCTL	On-board regulator control pin	76	61	53	N6
	VWAKEUP	The return signal input pin from a hibernation state	77	62	54	M6
SD I/F	S_CLK_0	SD memory card interface SD memory card clock output pin	38	28	23	H3
	S_CMD_0	SD memory card interface SD memory card command output	41	31	26	H6
	S_DATA1_0	SD memory card interface SD memory card data bus	36	26	21	H2
	S_DATA0_0		37	27	22	J1
	S_DATA3_0		42	32	27	J5
	S_DATA2_0		43	33	28	J4
	S_CD_0	SD memory card interface SD memory card detection pin	45	35	30	J2
S_WP_0	SD memory card interface SD memory card write protection	44	34	29	J3	

Module	Pin Name	Function	Pin Number			
			LQFP 216	LQFP 176	LQFP 144	LBE 192
Ethernet	E_COL	Collision detection	186	154	124	F8
	E_COUT	Clock output for Ethernet PHY	190	158	128	A7
	E_CRS	Carrier detection	187	155	125	B7
	E_MDC	Management clock	184	152	122	E8
	E_MDIO	Management data I/O	183	151	121	D8
	E_PPS	PTP counter monitor	198	166	136	D6
	E_RX00	Received data0	181	149	119	F9
	E_RX01	Received data1	180	148	118	E9
	E_RX02	Received data2	179	147	117	D9
	E_RX03	Received data3	178	146	116	B8
	E_RXCK_RE FCK	Received clock input/ Reference clock	185	153	123	A10
	E_RXDV	Received data enable	182	150	120	C8
	E_RXER	Received data error detection	177	145	115	C9
	E_TCK	Transition clock input	191	159	129	C7
	E_TX00	Transition data0	196	164	134	B6
	E_TX01	Transition data1	195	163	133	F7
	E_TX02	Transition data2	194	162	132	E7
	E_TX03	Transition data3	193	161	131	D7
E_TXEN	Transition data enable	197	165	135	C6	
E_TXER	Transition data error detection	192	160	130	A6	
HDMI-CEC/ remote control reception	CEC0_0	HDMI-CEC/remote control reception ch 0 input/output pin	80	65	55	L6
	CEC1_0	HDMI-CEC/remote control reception ch 1 input/output pin	212	172	140	B3
I ² S	I2SMCLK_0	I ² S external clock pin	51	41	-	L2
	I2SDO_0	I ² S serial transition data output pin	52	42	-	L3
	I2SWS_0	I ² S frame synchronization signal pin	53	43	-	M2
	I2SDI_0	I ² S serial received data input pin	34	24	-	G6
	I2SCK_0	I ² S bit clock pin	35	25	-	H4
High-speed quad SPI	Q_SCK_0	SPI clock output pin	173	143	-	D10
	Q_IO0_0	SPI data input/output pin	172	142	-	C10
	Q_IO1_0		171	141	-	B10
	Q_IO2_0		170	140	-	D11
	Q_IO3_0		169	139	-	C11
	Q_CS0_0	SPI chip select output pin	174	144	-	B9
	Q_CS1_0		175	-	-	-
	Q_CS2_0		176	-	-	-

Module	Pin Name	Function	Pin Number			
			LQFP 216	LQFP 176	LQFP 144	LBE 192
Reset	INITX	External reset Input pin A reset is valid when INITX = "L."	72	57	49	N5
Mode	MD1	Mode 1 pin During serial programming to flash memory, MD1 = "L" must be input.	104	84	68	N13
	MD0	Mode 0 pin During normal operation, MD0 = "L" must be input. During serial programming to flash memory, MD0 = "H" must be input.	105	85	69	N12
Power	VCC	Power supply pin	1	1	1	C1
			39	29	24	H1
			55	45	37	N1
			64	54	46	P4
			109	89	73	M14
			137	-	-	-
	163	133	109	A13		
	USBVCC0	3.3V power supply port for USB I/O	213	173	141	A4
USBVCC1	159		129	105	E14	
ETHVCC	Power supply pin for Ethernet I/O	188	156	126	A9	
GND	VSS	GND pin	40	30	25	H5
			54	44	36	M1
			63	53	45	P3
			108	88	72	N14
			136	-	-	-
			162	132	108	B14
			189	157	127	A8
			216	176	144	B1
			-	-	-	E1
			-	-	-	G1
			-	-	-	P7
			-	-	-	P11
			-	-	-	L14
			-	-	-	A11
			-	-	-	A5
			-	-	-	N7
			-	-	-	M7
			-	-	-	K7
			-	-	-	J7
			-	-	-	G7
-	-	-	H7			
-	-	-	H8			
-	-	-	G8			

Module	Pin Name	Function	Pin Number			
			LQFP 216	LQFP 176	LQFP 144	LBE 192
Clock	X0	Main clock (oscillation) input pin	106	86	70	P12
	X1	Main clock (oscillation) I/O pin	73	58	50	P5
	X0A	Sub clock (oscillation) input pin	107	87	71	P13
	X1A	Sub clock (oscillation) I/O pin	74	59	51	P6
	CROUT_0	Built-in high-speed CR-oscillation clock output port	157	127	103	D13
	CROUT_1		184	152	122	E8
Analog power	AVCC	A/D converter and D/A converter analog power-supply pin	110	90	74	M13
	AVRL	A/D converter analog reference voltage input pin	112	92	76	L13
	AVRH	A/D converter analog reference voltage input pin	113	93	77	L12
VBAT power	VBAT	VBAT power supply pin Backup power supply (battery etc.) and system power supply	75	60	52	P8
Analog GND	AVSS	A/D converter and D/A converter GND pin	111	91	75	M12
C pin	C	Power supply stabilization capacity pin	62	52	44	P2

7. I/O Circuit Type

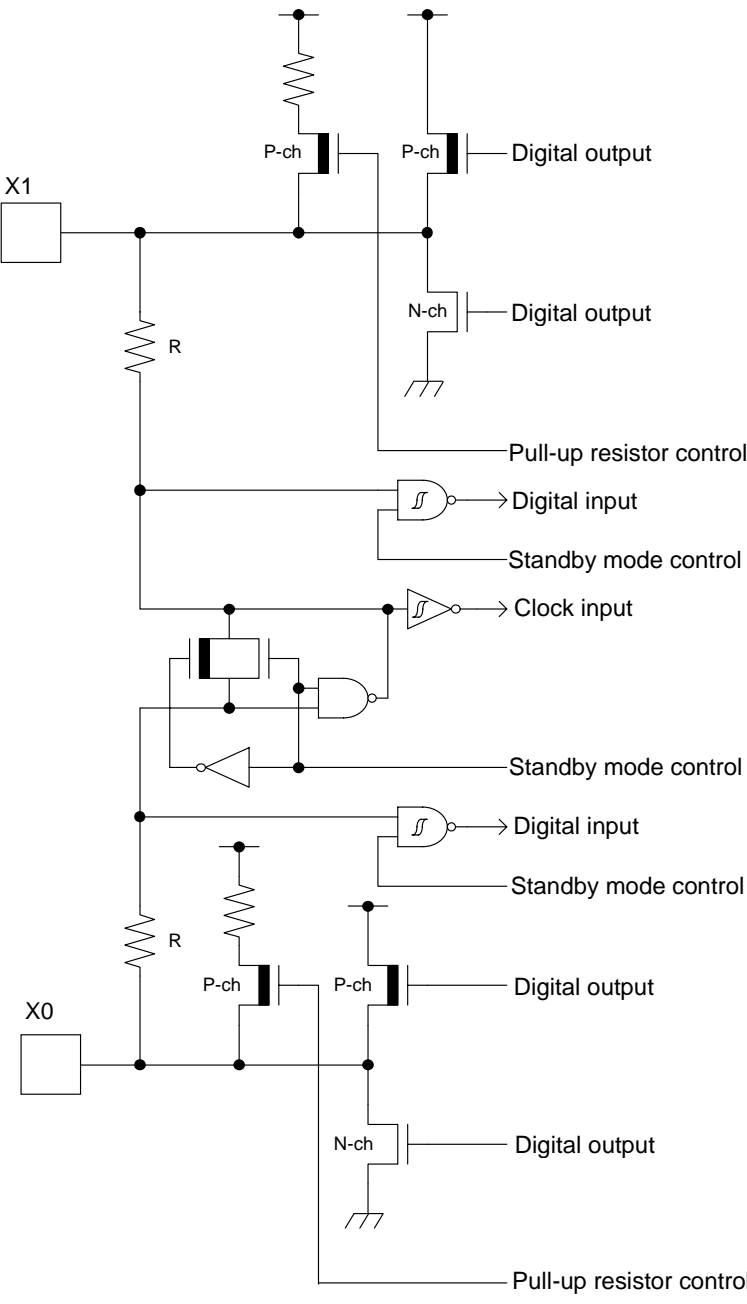
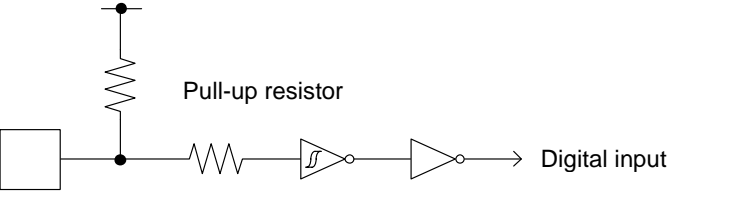
Type	Circuit	Remarks
A		<p>It is possible to select the main oscillation/GPIO function.</p> <p>When the main oscillation is selected:</p> <ul style="list-style-type: none"> • Oscillation feedback resistor: approximately 1 MΩ • Standby mode control <p>When the GPIO is selected:</p> <ul style="list-style-type: none"> • CMOS level output. • CMOS level hysteresis input • Pull-up resistor control • Standby mode control • Pull-up resistor: approximately 50 kΩ • $I_{OH} = -4 \text{ mA}$, $I_{OL} = 4 \text{ mA}$
B		<ul style="list-style-type: none"> • CMOS level hysteresis input • Pull-up resistor: approximately 50 kΩ

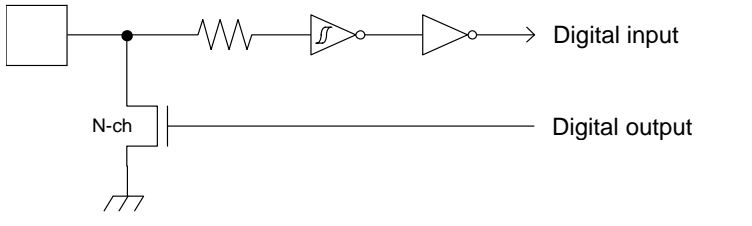
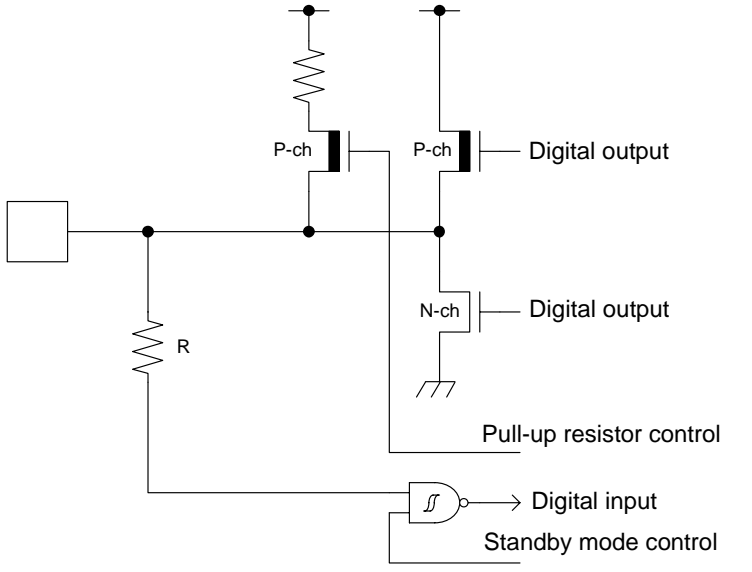
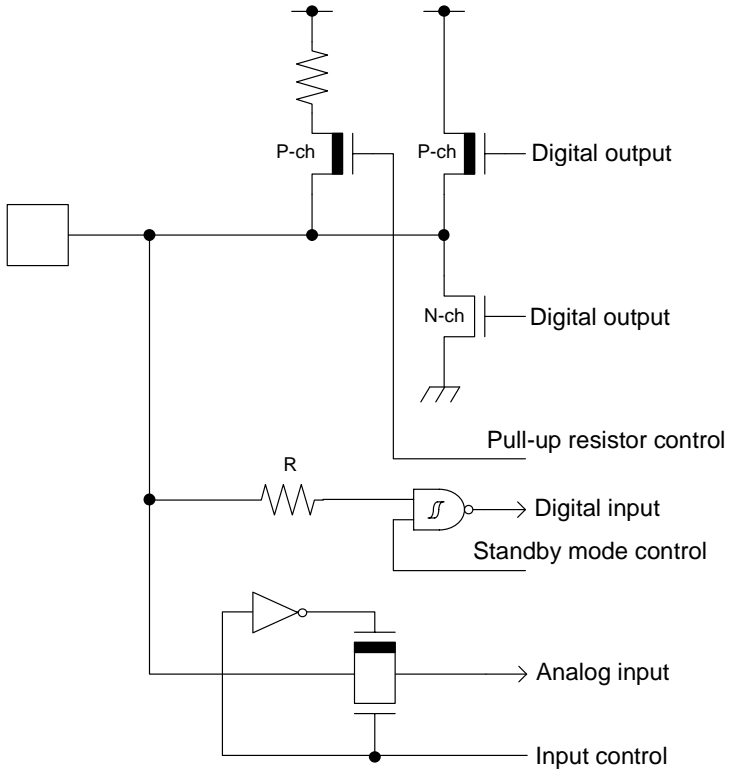
Type	Circuit	Remarks
C		<ul style="list-style-type: none"> • Open drain output • CMOS level hysteresis input
E		<ul style="list-style-type: none"> • CMOS level output • CMOS level hysteresis input • Pull-up resistor control • Standby mode control • Pull-up resistor: approximately 50 kΩ • $I_{OH} = -4 \text{ mA}$, $I_{OL} = 4 \text{ mA}$
F		<ul style="list-style-type: none"> • CMOS level output • CMOS level hysteresis input • Input control • Analog input • Pull-up resistor control • Standby mode control • Pull-up resistor: approximately 50 kΩ • $I_{OH} = -4 \text{ mA}$, $I_{OL} = 4 \text{ mA}$

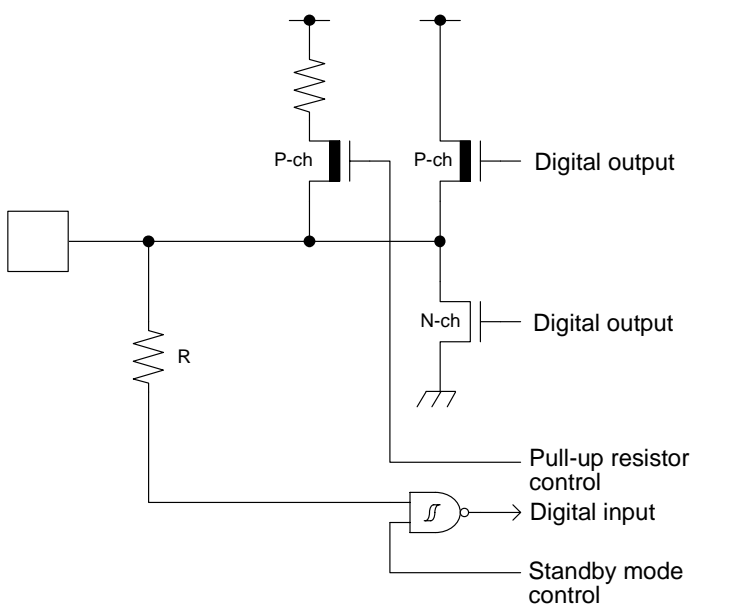
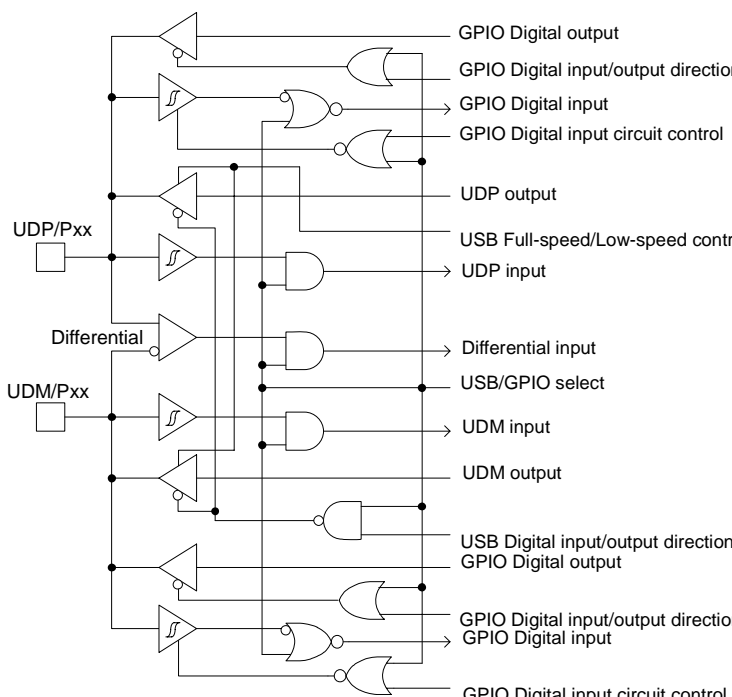
Type	Circuit	Remarks
G	 <p>The diagram shows a CMOS output stage. A pull-up resistor R is connected to the output node. The output node is driven by a P-channel MOSFET (P-ch) and an N-channel MOSFET (N-ch). The P-ch MOSFET's gate is connected to a digital input signal. The N-ch MOSFET's gate is connected to a digital input signal through an inverter. The output node is connected to a digital output pin. A pull-up resistor control signal is connected to the gate of the P-ch MOSFET. A standby mode control signal is connected to the gate of the N-ch MOSFET.</p>	<ul style="list-style-type: none"> • CMOS level output • CMOS level hysteresis input • Pull-up resistor control • Standby mode control • Pull-up resistor: approximately 50 kΩ • $I_{OH} = -12 \text{ mA}$, $I_{OL} = 12 \text{ mA}$
H	 <p>The diagram shows a complex digital I/O block. It includes several input pins: UDP/Pxx, Differential, and UDM/Pxx. Each input pin is connected to a buffer and a logic gate. The output pins are: GPIO Digital output, GPIO Digital input/output direction, GPIO Digital input, GPIO Digital input circuit control, UDP output, USB Full-speed/Low-speed control, UDP input, Differential input, USB/GPIO select, UDM input, UDM output, USB Digital input/output direction, GPIO Digital output, GPIO Digital input/output direction, GPIO Digital input, and GPIO Digital input circuit control. The circuit uses a combination of buffers, inverters, AND gates, and OR gates to implement the logic.</p>	<p>It is possible to select either USB I/O or GPIO function.</p> <p>When the USB I/O is selected:</p> <ul style="list-style-type: none"> • Full-speed, low-speed control <p>When the GPIO is selected:</p> <ul style="list-style-type: none"> • CMOS level output • CMOS level hysteresis input • Standby mode control • $I_{OH} = -20.5 \text{ mA}$, $I_{OL} = 18.5 \text{ mA}$

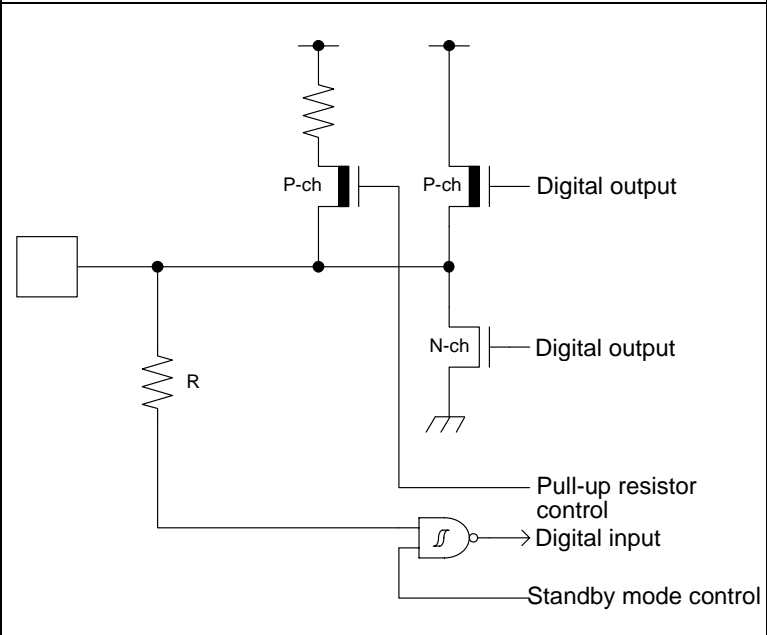
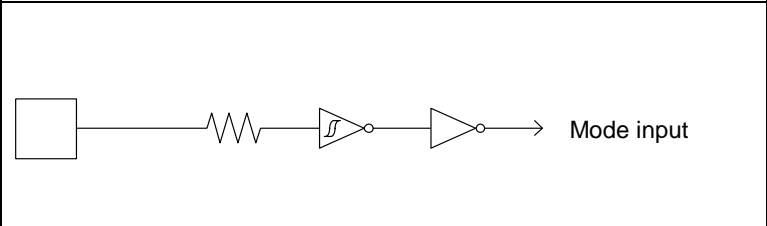
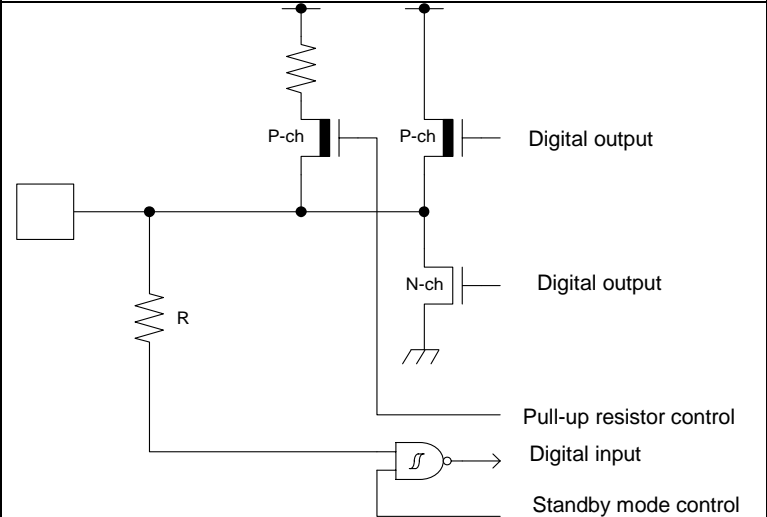
Type	Circuit	Remarks
I		<ul style="list-style-type: none"> • CMOS level output • CMOS level hysteresis input • 5V tolerant • Pull-up resistor control • Standby mode control • Pull-up resistor: approximately 50 kΩ • $I_{OH} = -4\text{ mA}$, $I_{OL} = 4\text{ mA}$ • Available to control of PZR registers (pseudo-open drain control) • For PZR registers, refer to GPIO in the “FM4 Family Peripheral Manual Main Part (MN709-00001)”.
J		<p>CMOS level hysteresis input</p>
K		<ul style="list-style-type: none"> • CMOS level output • TTL level hysteresis input • Pull-up resistor control • Standby mode control • Pull-up resistor: approximately 50 kΩ • $I_{OH} = -4\text{ mA}$, $I_{OL} = 4\text{ mA}$

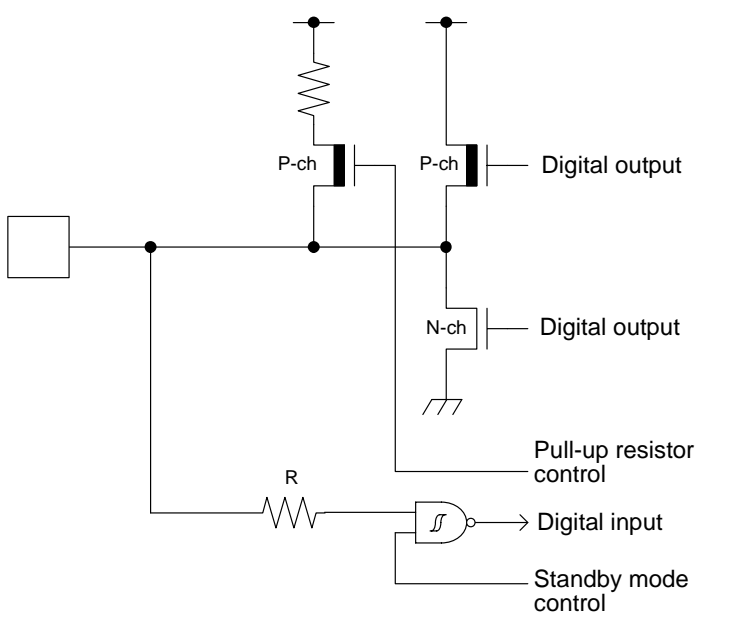
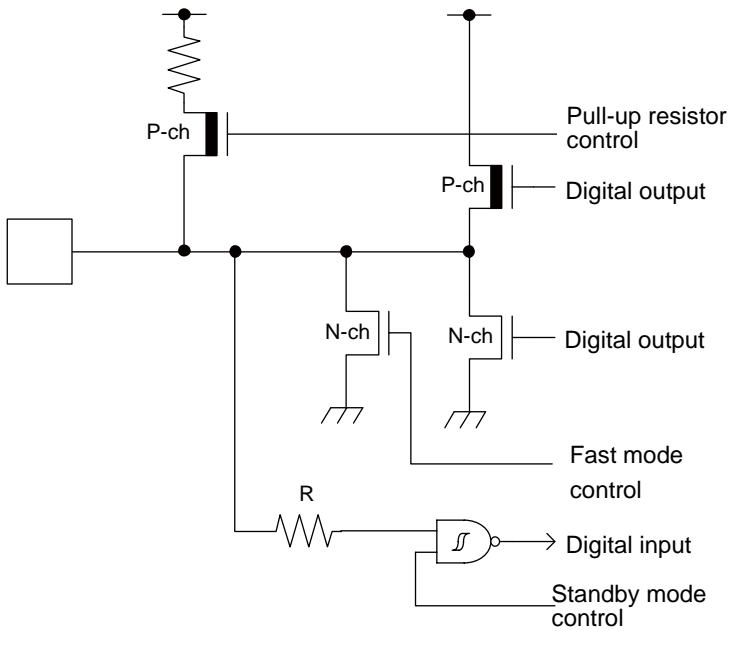
Type	Circuit	Remarks
L		<ul style="list-style-type: none"> • CMOS level output • CMOS level hysteresis input • Pull-up resistor control • Standby mode control • Pull-up resistor: approximately 50 kΩ • $I_{OH} = -8 \text{ mA}$, $I_{OL} = 8 \text{ mA}$
N		<ul style="list-style-type: none"> • CMOS level output • CMOS level hysteresis input • 5V tolerant • Pull-up resistor control • Standby mode control • Pull-up resistor: approximately 50 kΩ • $I_{OH} = -4 \text{ mA}$, $I_{OL} = 4 \text{ mA}$ (GPIO) • $I_{OL} = 20 \text{ mA}$ (Fast mode Plus) • Available to control of PZR register (pseudo-open drain control) • For PZR registers, refer to GPIO in the "FM4 Family Peripheral Manual Main Part (MN709-00001)".

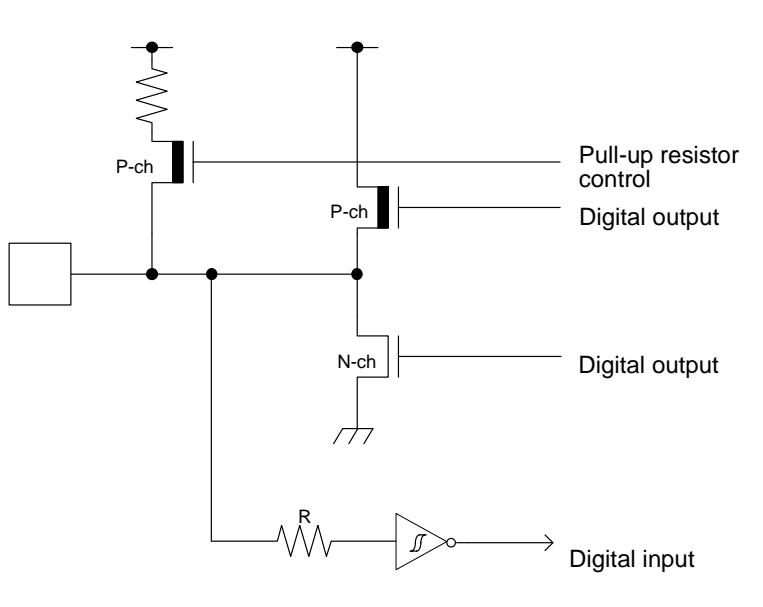
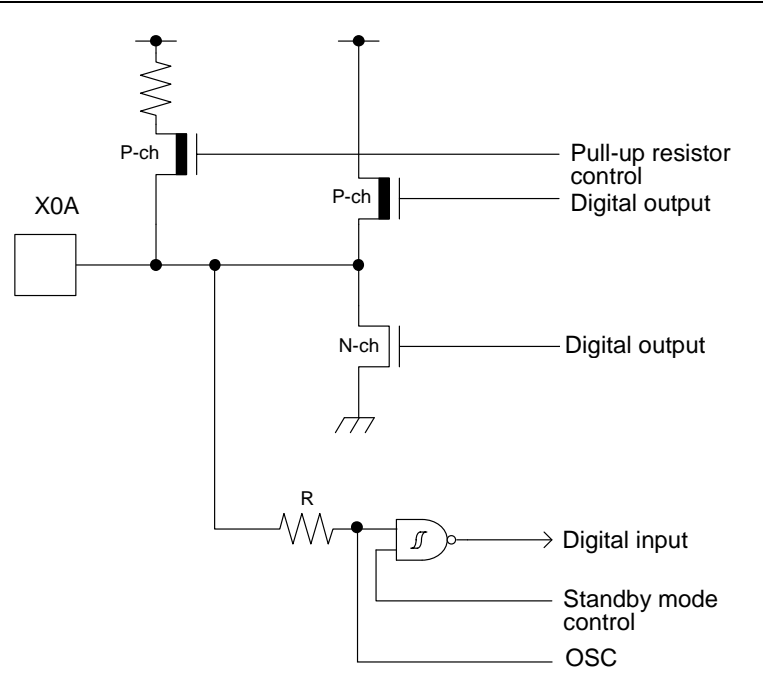
Type	Circuit	Remarks
O		<ul style="list-style-type: none"> • CMOS level output • CMOS level hysteresis input • 5V tolerant • Pull-up resistor control • Pull-up resistor: approximately 50 kΩ • $I_{OH} = -4 \text{ mA}$, $I_{OL} = 4 \text{ mA}$ • Available to control of PZR register (pseudo-open drain control) • For PZR registers, refer to GPIO in the "FM4 Family Peripheral Manual Main Part (MN709-00001)". • For I/O setting, refer to VBAT Domain in the "FM4 Family Peripheral Manual Main Part (MN709-00001)."
P		<ul style="list-style-type: none"> • CMOS level output • CMOS level hysteresis input • Pull-up resistor control • Pull-up resistor: approximately 50 kΩ • $I_{OH} = -4 \text{ mA}$, $I_{OL} = 4 \text{ mA}$ • For I/O setting, refer to VBAT Domain in the "FM4 Family Peripheral Manual Main Part (MN709-00001)."

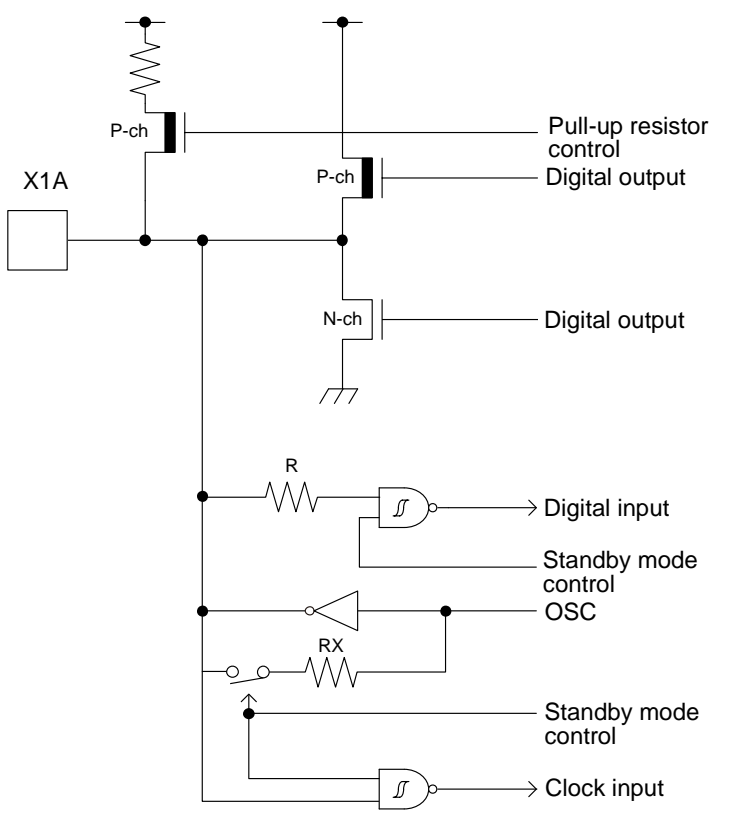
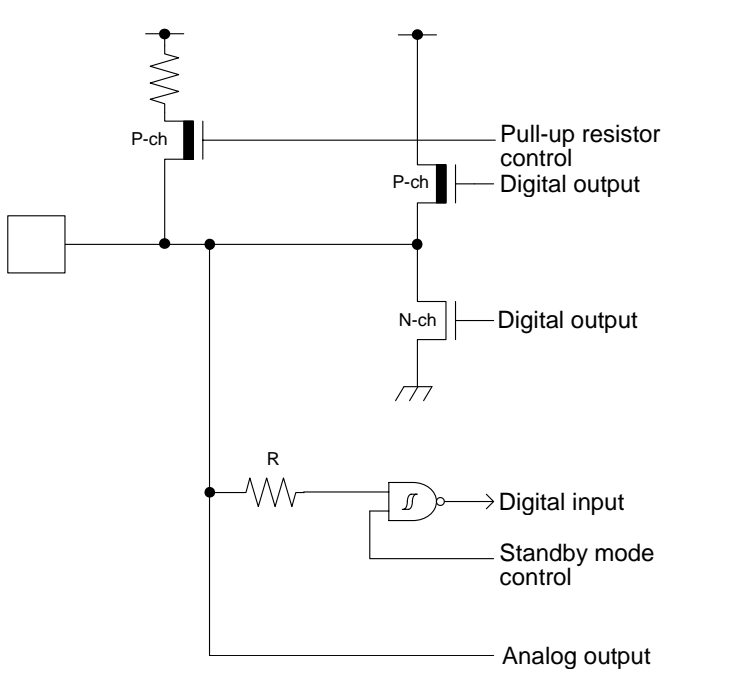
Type	Circuit	Remarks
Q		<p>It is possible to select the sub oscillation/GPIO function.</p> <p>When the sub oscillation is selected:</p> <ul style="list-style-type: none"> Oscillation feedback resistor: approximately 10 MΩ <p>When the GPIO is selected:</p> <ul style="list-style-type: none"> CMOS level output. CMOS level hysteresis input Pull-up resistor control Pull-up resistor: approximately 50 kΩ $I_{OH} = -4 \text{ mA}$, $I_{OL} = 4 \text{ mA}$ For I/O setting, refer to VBAT Domain in the "FM4 Family Peripheral Manual Main Part (MN709-00001)."
R		<ul style="list-style-type: none"> CMOS level output CMOS level hysteresis input Analog output Pull-up resistor control Standby mode control Pull-up resistor: approximately 50 kΩ $I_{OH} = -4 \text{ mA}$, $I_{OL} = 4 \text{ mA}$ (4.5V to 5.5V) $I_{OH} = -2 \text{ mA}$, $I_{OL} = 2 \text{ mA}$ (2.7V to 4.5V)

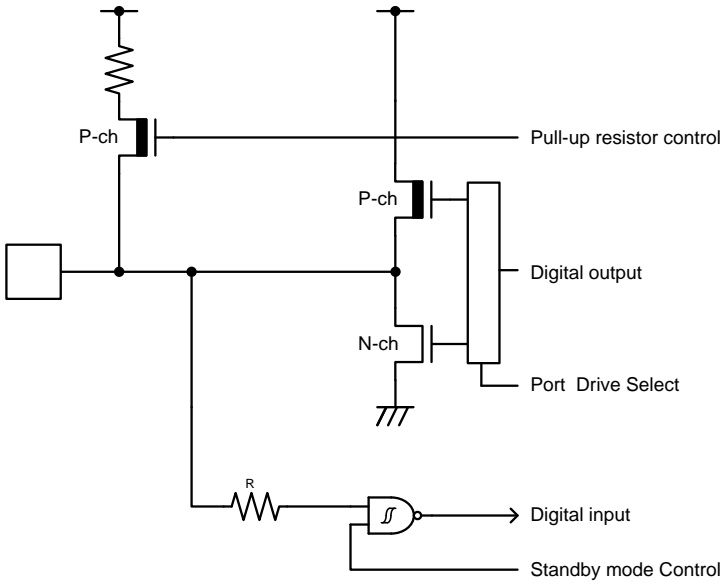
Type	Circuit	Remarks
S	 <p>The circuit diagram shows a pull-up resistor connected to a supply rail. A P-channel MOSFET (P-ch) is connected between the supply rail and the node. The node is also connected to the gate of an N-channel MOSFET (N-ch) and to the input of a digital output driver. The digital output driver has a P-ch MOSFET connected to the supply rail and an N-ch MOSFET connected to ground. The output of the driver is labeled 'Digital output'. A 'Port Drive Select' input is connected to the driver. A digital input is connected to the node through a resistor 'R'. A 'Standby mode Control' input is connected to the digital input through an inverter.</p>	<ul style="list-style-type: none"> • CMOS level output • (It is possible to select by port drive capability. Select register [PDSR]) • CMOS level hysteresis input • Pull-up resistor control • Standby mode control • Pull-up resistor: approximately 50 kΩ • $I_{OH} = -12 \text{ mA}$, $I_{OL} = 12 \text{ mA}$ (PDSR = 1) • $I_{OH} = -4 \text{ mA}$, $I_{OL} = 4 \text{ mA}$ (PDSR = 0)

8. Handling Precautions

Every semiconductor device has a characteristic, inherent rate of failure. The possibility of failure is greatly affected by the conditions in which they are used (circuit conditions, environmental conditions, etc.). This page describes precautions that must be observed to minimize the chance of failure and to obtain higher reliability from your Spansion semiconductor devices.

8.1 Precautions for Product Design

This section describes precautions when designing electronic equipment using semiconductor devices.

Absolute Maximum Ratings

Semiconductor devices can be permanently damaged by application of stress (voltage, current, temperature, etc.) in excess of certain established limits, called absolute maximum ratings. Do not exceed these ratings.

Recommended Operating Conditions

Recommended operating conditions are normal operating ranges for the semiconductor device. All the device's electrical characteristics are warranted when operated within these ranges.

Always use semiconductor devices within the recommended operating conditions. Operation outside these ranges may adversely affect reliability and could result in device failure.

No warranty is made with respect to uses, operating conditions, or combinations not represented on the data sheet. Users considering application outside the listed conditions are advised to contact their sales representative beforehand.

Processing and Protection of Pins

These precautions must be followed when handling the pins that connect semiconductor devices to power supply and I/O functions.

1. Preventing Over-Voltage and Over-Current Conditions

Exposure to voltage or current levels in excess of maximum ratings at any pin is likely to cause deterioration within the device, and in extreme cases leads to permanent damage of the device. Try to prevent such overvoltage or over-current conditions at the design stage.

2. Protection of Output Pins

Shorting of output pins to supply pins or other output pins, or connection to large capacitance can cause large current flows. Such conditions, if present for extended periods of time, can damage the device; therefore, avoid this type of connection.

3. Handling of Unused Input Pins

Unconnected input pins with very high impedance levels can adversely affect stability of operation. Such pins should be connected through an appropriate resistance to a power-supply pin or ground pin.

Code: DS00-00004-3E

Latch-Up

Semiconductor devices are constructed by the formation of p-type and n-type areas on a substrate. When subjected to abnormally high voltages, internal parasitic pnpn junctions (called thyristor structures) may be formed, causing large current levels in excess of several hundred milliamps to flow continuously at the power supply pin. This condition is called latch-up.

CAUTION: The occurrence of latch-up not only causes loss of reliability in the semiconductor device, but can cause injury or damage from high heat, smoke or flame. To prevent this from happening, do the following:

1. Be sure that voltages applied to pins do not exceed the absolute maximum ratings. This should include attention to abnormal noise, surge levels, etc.
2. Be sure that abnormal current flows do not occur during the power-on sequence.

Observance of Safety Regulations and Standards

Most countries in the world have established standards and regulations regarding safety, protection from electromagnetic interference, etc. Customers are requested to observe applicable regulations and standards in the design of products.

Fail-Safe Design

As previously mentioned, all semiconductor devices have inherent rates of failure. You must protect against injury, damage or loss from such failures by incorporating safety design measures into your facility and equipment such as redundancy, fire protection, and prevention of over-current levels and other abnormal operating conditions.

Precautions Related to Usage of Devices

SpanSion semiconductor devices are intended for use in standard applications (computers, office automation and other office equipment, industrial, communications, and measurement equipment, personal or household devices, etc.).

CAUTION: Customers considering the use of our products in special applications where failure or abnormal operation may directly affect human lives or cause physical injury or property damage, or where extremely high levels of reliability are demanded (such as aerospace systems, atomic energy controls, sea floor repeaters, vehicle operating controls, medical devices for life support, etc.) are requested to consult with sales representatives before such use. The company will not be responsible for damages arising from such use without prior approval.

8.2 Precautions for Package Mounting

Package mounting may be either lead insertion type or surface mount type. In either case, for heat resistance during soldering, you should only mount under SpanSion's recommended conditions. For detailed information about mount conditions, contact your sales representative.

Lead Insertion Type

Mounting of lead insertion type packages onto printed circuit boards may be done by two methods: direct soldering on the board, or mounting by using a socket.

Direct mounting onto boards normally involves processes for inserting leads into through-holes on the board and using the flow soldering (wave soldering) method of applying liquid solder. In this case, the soldering process usually causes leads to be subjected to thermal stress in excess of the absolute ratings for storage temperature. Mounting processes should conform to SpanSion recommended mounting conditions.

If socket mounting is used, differences in surface treatment of the socket contacts and IC lead surfaces can lead to contact deterioration after long periods. For this reason it is recommended that the surface treatment of socket contacts and IC leads be verified before mounting.

Surface Mount Type

Surface mount packaging has longer and thinner leads than lead-insertion packaging, and therefore leads are more easily deformed or bent. The use of packages with higher pin counts and narrower pin pitch results in increased susceptibility to open connections caused by deformed pins, or shorting due to solder bridges.

You must use appropriate mounting techniques. SpanSion recommends the solder reflow method, and has established a ranking of mounting conditions for each product. Users are advised to mount packages in accordance with SpanSion ranking of recommended conditions.

Lead-Free Packaging

CAUTION: When ball grid array (BGA) packages with Sn-Ag-Cu balls are mounted using Sn-Pb eutectic soldering, junction strength may be reduced under some conditions of use.

Storage of Semiconductor Devices

Because plastic chip packages are formed from plastic resins, exposure to natural environmental conditions will cause absorption of moisture. During mounting, the application of heat to a package that has absorbed moisture can cause surfaces to peel, reducing moisture resistance and causing packages to crack. To prevent this, do the following:

1. Avoid exposure to rapid temperature changes, which can cause moisture to condense inside the product. Store products in locations where temperature changes are slight.
2. Use dry boxes for product storage. Products should be stored below 70% relative humidity, and at temperatures between 5°C and 30°C.
3. When Dry Packages are opened, it is recommended to have humidity between 40% and 70%.
4. When necessary, SpanSion packages semiconductor devices in highly moisture-resistant aluminum laminate bags, with a silica gel desiccant. Devices should be sealed in these aluminum laminate bags for storage.
5. Avoid storing packages where they are exposed to corrosive gases or high levels of dust.

Baking

Packages that have absorbed moisture may be de-moisturized by baking (heat drying). Follow the SpanSion recommended conditions for baking.

Condition: 125°C/24 h

Static Electricity

Because semiconductor devices are particularly susceptible to damage by static electricity, you must take the following precautions:

1. Maintain relative humidity in the working environment between 40% and 70%. Use of an apparatus for ion generation may be needed to remove electricity.
2. Electrically ground all conveyors, solder vessels, soldering irons, and peripheral equipment.
3. Eliminate static body electricity by the use of rings or bracelets connected to ground through high resistance (on the level of 1 MΩ). Wearing of conductive clothing and shoes, and the use of conductive floor mats and other measures to minimize shock loads is recommended.
4. Ground all fixtures and instruments, or protect with anti-static measures.
5. Avoid the use of Styrofoam or other highly static-prone materials for storage of completed board assemblies.

8.3 Precautions for Use Environment

Reliability of semiconductor devices depends on ambient temperature and other conditions as described above.

For reliable performance, do the following:

1. Humidity
Prolonged use in high humidity can lead to leakage in devices as well as printed circuit boards. If high humidity levels are anticipated, consider anti-humidity processing.
2. Discharge of static electricity
When high-voltage charges exist close to semiconductor devices, discharges can cause abnormal operation. In such cases, use anti-static measures or processing to prevent discharges.
3. Corrosive gases, dust, or oil
Exposure to corrosive gases or contact with dust or oil may lead to chemical reactions that will adversely affect the device. If you use devices in such conditions, consider ways to prevent such exposure or to protect the devices.
4. Radiation, including cosmic radiation
Most devices are not designed for environments involving exposure to radiation or cosmic radiation. Users should provide shielding as appropriate.
5. Smoke, flame
CAUTION: Plastic molded devices are flammable and therefore should not be used near combustible substances. If devices begin to smoke or burn, there is danger of the release of toxic gases.

Customers considering the use of Spansion products in other special environmental conditions should consult with sales representatives.

Please check the latest handling precautions at the following URL.

<http://www.spansion.com/fjdocuments/fj/datasheet/e-ds/DS00-00004.pdf>

9. Handling Devices

Power-Supply Pins

In products with multiple VCC and VSS pins, respective pins at the same potential are interconnected within the device in order to prevent malfunctions such as latch-up. All of these pins should be connected externally to the power supply or ground lines, however, in order to reduce electromagnetic emission levels, to prevent abnormal operation of strobe signals caused by the rise in the ground level, and to conform to the total output current rating.

Be sure to connect the current-supply source with the power pins and GND pins of this device at low impedance. It is also advisable that a ceramic capacitor of approximately 0.1 μF be connected as a bypass capacitor between VCC and VSS near this device.

A malfunction may occur when the power-supply voltage fluctuates rapidly even though the fluctuation is within the guaranteed operating range of the VCC power supply voltage. As a rule of voltage stabilization, suppress voltage fluctuation so that the fluctuation in VCC ripple (peak-to-peak value) at the commercial frequency (50 Hz/60 Hz) does not exceed 10% of the standard VCC value, and the transient fluctuation rate does not exceed 0.1V/ μs at a momentary fluctuation such as switching the power supply.

Crystal Oscillator Circuit

Noise near the X0/X1 and X0A/X1A pins may cause the device to malfunction. Design the printed circuit board so that X0/X1, X0A/X1A pins, the crystal oscillator (or ceramic oscillator), and the bypass capacitor to ground are located as close to the device as possible.

It is strongly recommended that the PC board artwork be designed such that the X0/X1 and X0A/X1A pins are surrounded by ground plane, as this is expected to produce stable operation.

Evaluate the oscillation introduced by the use of the crystal oscillator by your mount board.

Sub Crystal Oscillator

The sub-oscillator circuit for devices in this family is low gain to keep current consumption low. To stabilize the oscillation, Spansion recommends a crystal oscillator that meets the following conditions:

- Surface mount type
 - Size: More than 3.2 mm \times 1.5 mm
 - Load capacitance: approximately 6 pF to 7 pF
- Lead type
 - Load capacitance: approximately 6 pF to 7 pF

Using an External Clock

When using an external clock as an input of the main clock, set X0/X1 to the external clock input, and input the clock to X0. X1(PE3) can be used as a general-purpose I/O port. Similarly, when using an external clock as an input of the sub clock, set X0A/X1A to the external clock input and input the clock to X0A. X1A (P47) can be used as a general-purpose I/O port.

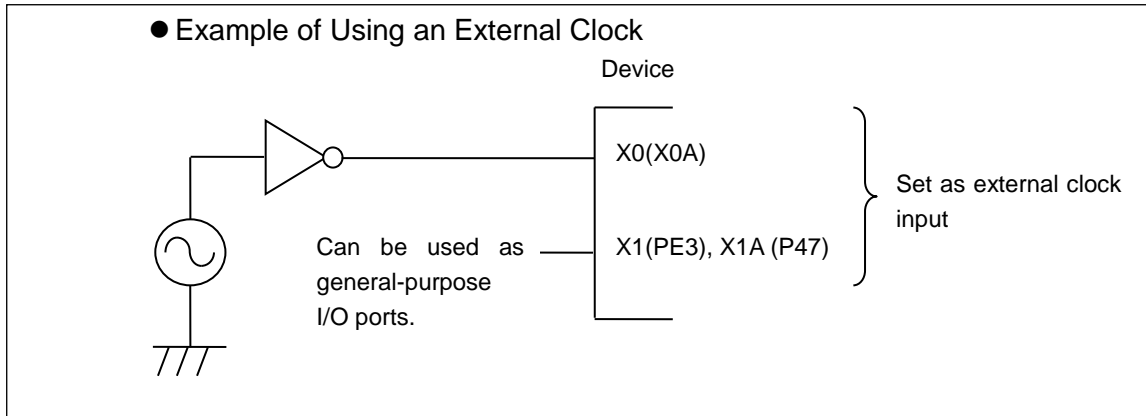

Handling When Using Multi-Function Serial Pin As I²C Pin

If the application uses the multi-function serial pin as an I²C pin, the P-channel transistor of the digital output must be disabled. I²C pins need to conform to electrical limitations like other pins, however, and avoid connecting to live external systems with the MCU power off.

C Pin

Devices in this series contain a regulator. Be sure to connect a smoothing capacitor (C_s) for the regulator between the C pin and the GND pin. Please use a ceramic capacitor or a capacitor of equivalent frequency characteristics as a smoothing capacitor. Some laminated ceramic capacitors have a large capacitance variation due to thermal fluctuation. Please select a capacitor that meets the specifications in the operating conditions to use by evaluating the temperature characteristics of the device. A smoothing capacitor of about 4.7 μ F would be recommended for this series.

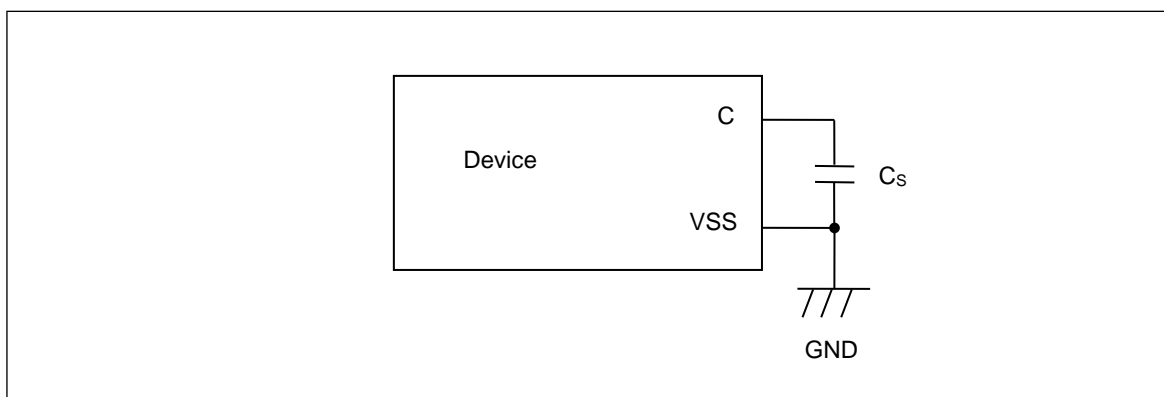

Mode Pins (MD0)

Connect the MD pin (MD0) directly to VCC or VSS pins. Design the printed circuit board such that the pull-up/down resistance stays low, the distance between the mode pins and VCC pins or VSS pins is as short as possible, and the connection impedance is low when the pins are pulled up/down such as for switching the pin level and rewriting the flash memory data. This is important to prevent the device from erroneously switching to test mode as a result of noise.

Notes On Power-On

Turn power on/off in the sequence shown below or at the same time. If not using the A/D converter and D/A converter, connect AVCC = VCC and AVSS = VSS.

Turning on: VBAT → VCC → USBVCC0
VBAT → VCC → USBVCC1
VBAT → VCC → ETHVCC
VCC → AVCC → AVRH

Turning off: USBVCC0 → VCC → VBAT
USBVCC1 → VCC → VBAT
ETHVCC → VCC → VBAT
AVRH → AVCC → VCC

Serial Communication

There is a possibility of receiving incorrect data as a result of noise or other issues introduced by the serial communication. Take care to design the printed circuit board to minimize noise.

Consider the case of introducing error as a result of noise, perform error detection such as by applying a checksum of data at the end. If an error is detected, retransmit the data.

Differences In Characteristics Within the Product Line

The electric characteristics including power consumption, ESD, latch-up, noise, and oscillation differ among members of the product line because chip layout and memory structures are not the same; for example, different sizes, flash versus ROM, etc. If you are switching to a different product of the same series, please make sure to evaluate the electric characteristics.

Pull-Up Function of 5V Tolerant I/O

Please do not input the signal more than VCC voltage at the time of Pull-Up function use of 5V tolerant I/O.

Pin Doubled As Debug Function

The pin doubled as TDO/TMS/TDI/TCK/TRSTX, SWO/SWDIO/SWCLK should be used as output only. Do not use as input.

10. Block Diagram

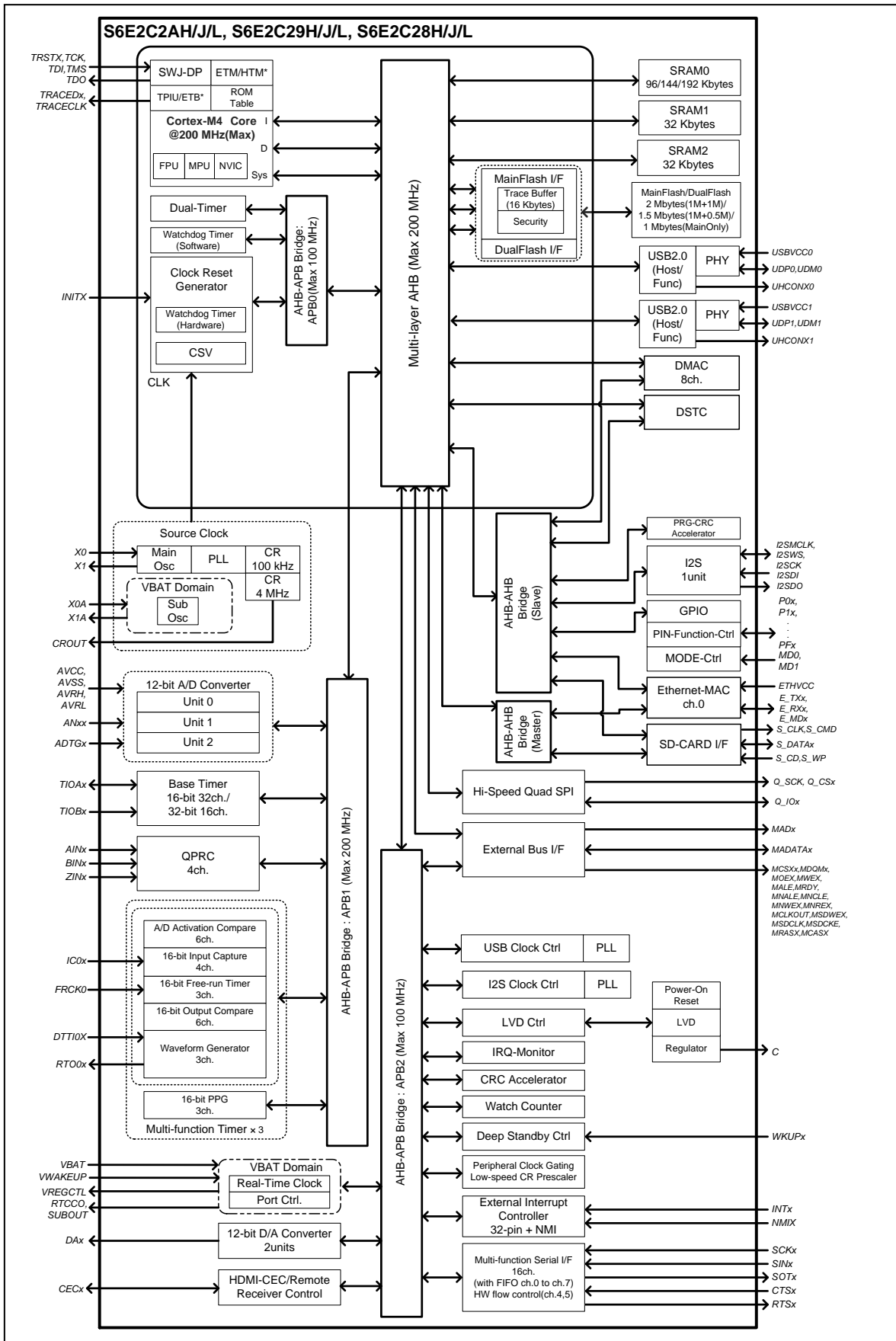

11. Memory Size

See "Memory size" in "3. Product Lineup" to confirm the memory size.

12. Memory Map

Memory Map (1)

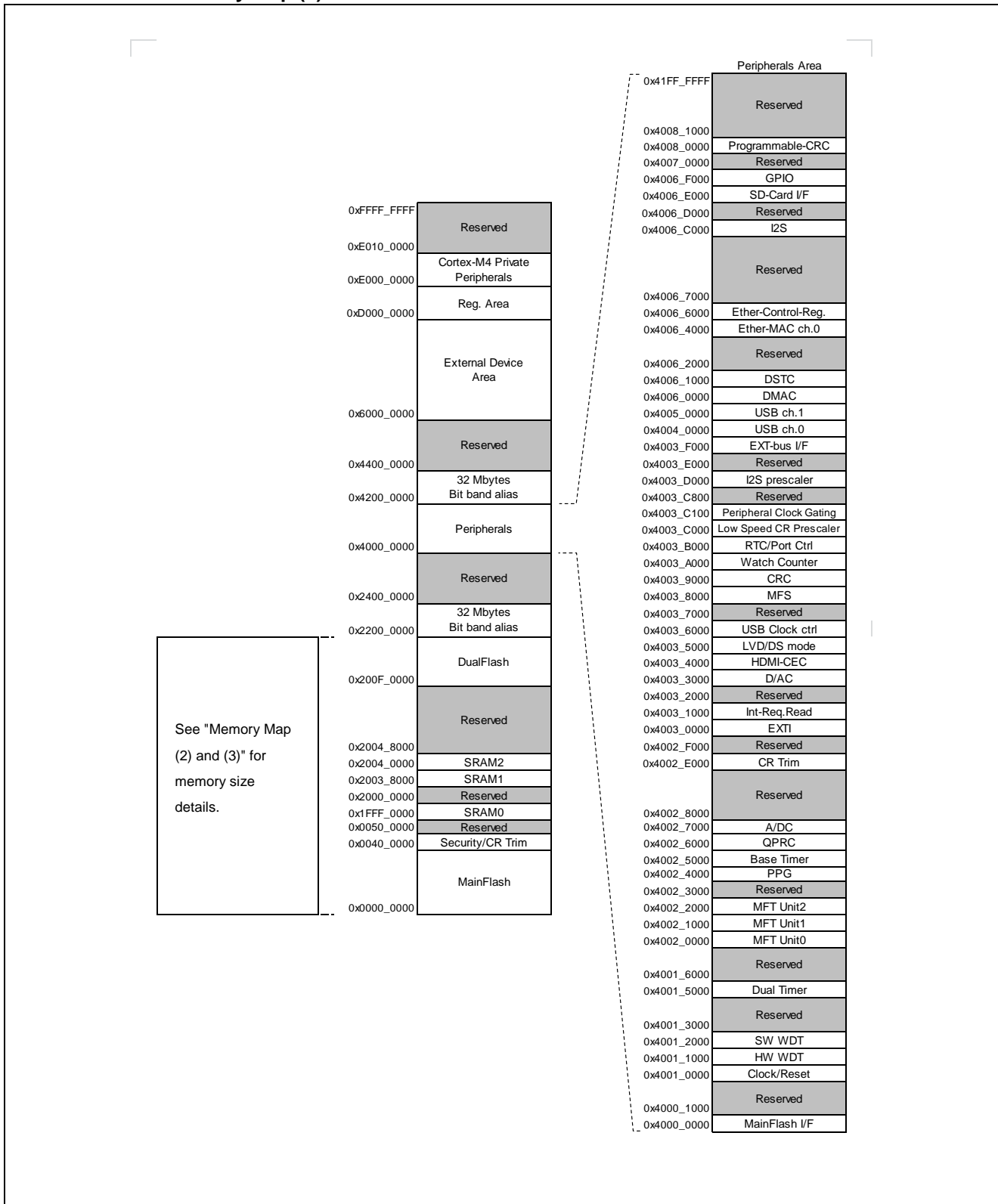

Memory Map (2)

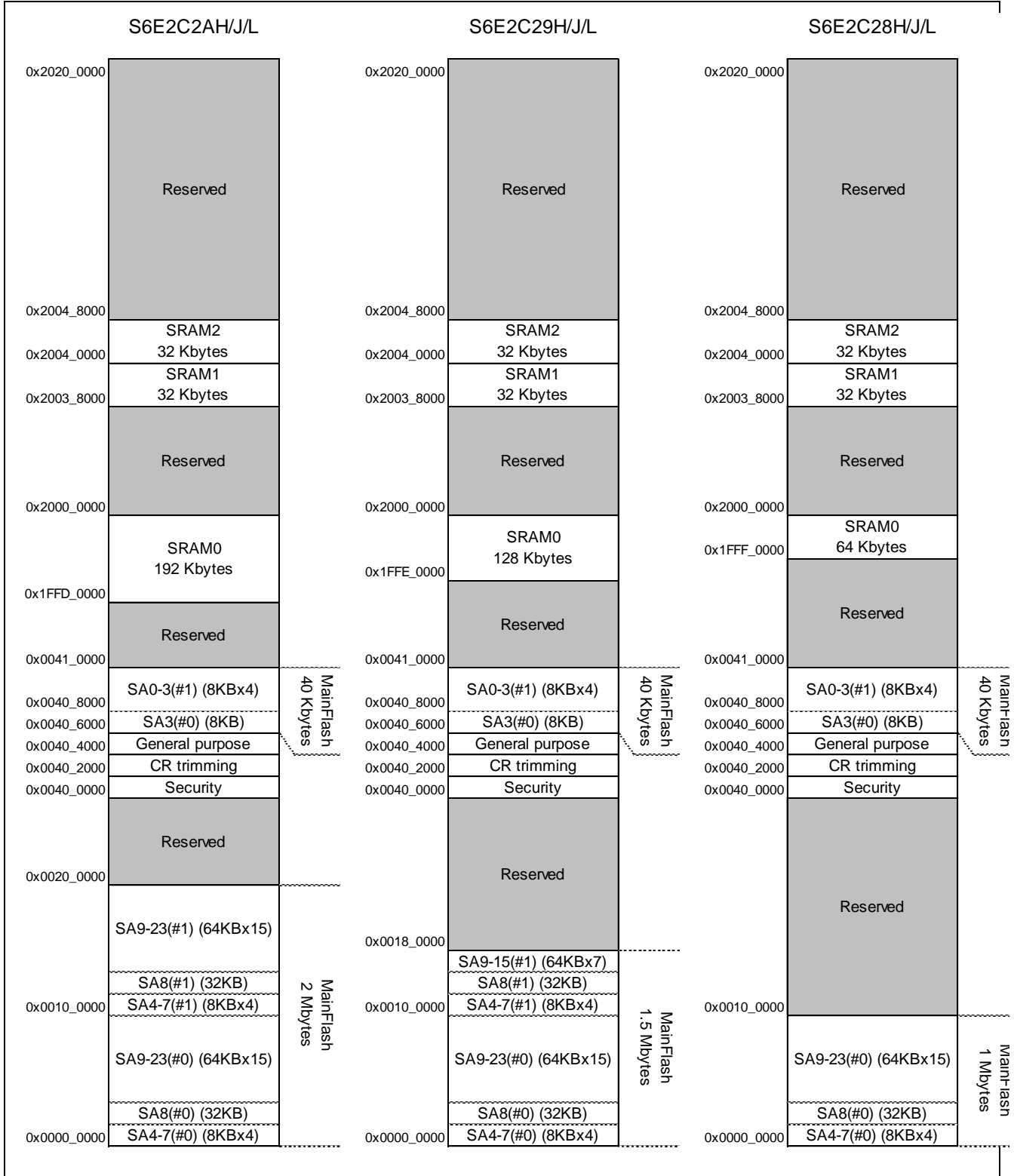

* See "S6E2CC/S6E2C5/S6E2C4/S6E2C3/S6E2C2/S6E2C1 Series Flash Programming Manual" to confirm the detail of flash Memory.

Memory Map (2) During Dual Flash Mode

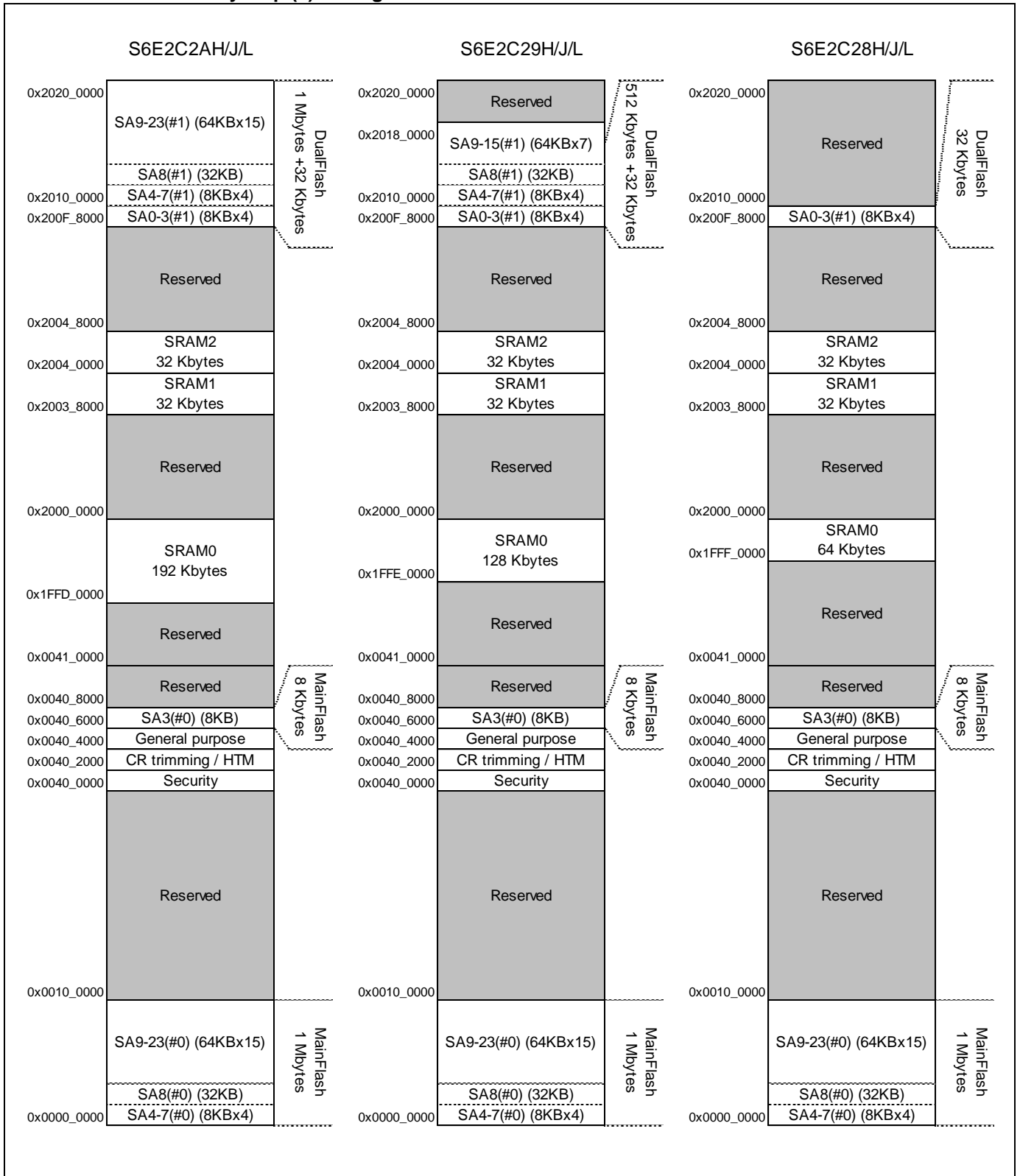

Memory Map (3)

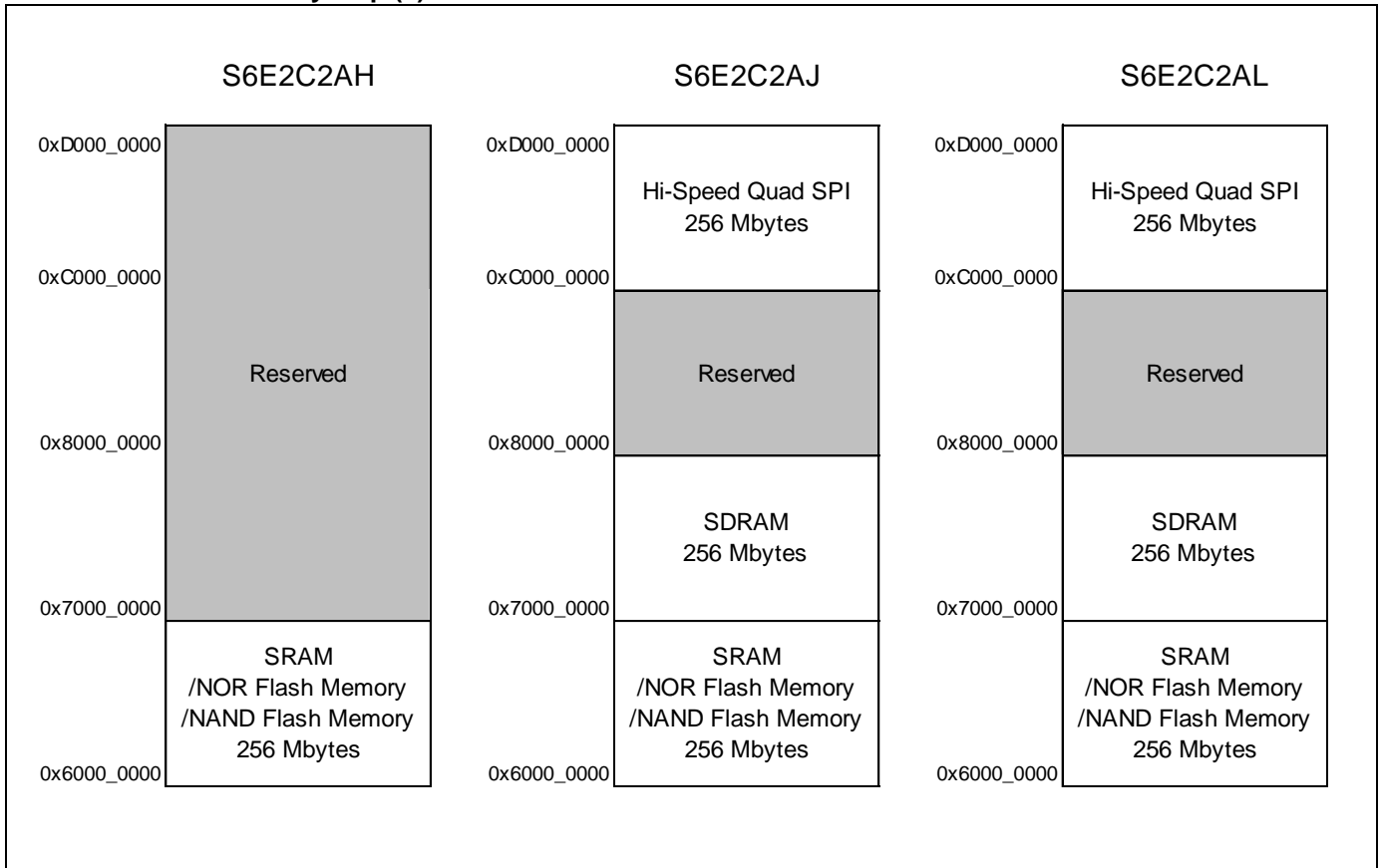

Peripheral Address Map

Start Address	End Address	Bus	Peripherals	
0x4000_0000	0x4000_0FFF	AHB	MainFlash I/F register	
0x4000_1000	0x4000_FFFF		Reserved	
0x4001_0000	0x4001_0FFF	APB0	Clock/reset control	
0x4001_1000	0x4001_1FFF		Hardware watchdog timer	
0x4001_2000	0x4001_2FFF		Software watchdog timer	
0x4001_3000	0x4001_4FFF		Reserved	
0x4001_5000	0x4001_5FFF		Dual-timer	
0x4001_6000	0x4001_FFFF		Reserved	
0x4002_0000	0x4002_0FFF		APB1	Multi-Function Timer unit 0
0x4002_1000	0x4002_1FFF	Multi-Function Timer unit 1		
0x4002_2000	0x4002_2FFF	Multi-Function Timer unit 1		
0x4002_3000	0x4002_3FFF	Reserved		
0x4002_4000	0x4002_4FFF	PPG		
0x4002_5000	0x4002_5FFF	Base timer		
0x4002_6000	0x4002_6FFF	Quadrature position/revolution counter		
0x4002_7000	0x4002_7FFF	A/D converter		
0x4002_8000	0x4002_DFFF	Reserved		
0x4002_E000	0x4002_EFFF	Internal CR trimming		
0x4002_F000	0x4002_FFFF	Reserved		
0x4003_0000	0x4003_0FFF	APB2		External interrupt controller
0x4003_1000	0x4003_1FFF			Interrupt request batch-read function
0x4003_2000	0x4003_2FFF		Reserved	
0x4003_3000	0x4003_3FFF		D/A converter	
0x4003_4000	0x4003_4FFF		HDMI-CEC	
0x4003_5000	0x4003_57FF		Low voltage detector	
0x4003_5800	0x4003_5FFF		Deep standby mode Controller	
0x4003_6000	0x4003_6FFF		USB clock generator	
0x4003_7000	0x4003_7FFF		Reserved	
0x4003_8000	0x4003_8FFF		Multi-function serial interface	
0x4003_9000	0x4003_9FFF		CRC	
0x4003_A000	0x4003_AFFF		Watch counter	
0x4003_B000	0x4003_BFFF		RTC/port control	
0x4003_C000	0x4003_C0FF		Low-speed CR prescaler	
0x4003_C100	0x4003_C7FF		Peripheral clock gating	
0x4003_C800	0x4003_CFFF		Reserved	
0x4003_D000	0x4003_DFFF		I ² S prescaler	
0x4003_E000	0x4003_EFFF		Reserved	
0x4003_F000	0x4003_FFFF		External memory interface	

Start Address	End Address	Bus	Peripherals
0x4004_0000	0x4004_FFFF	AHB	USB ch 0
0x4005_0000	0x4005_FFFF		USB ch 1
0x4006_0000	0x4006_0FFF		DMAC register
0x4006_1000	0x4006_1FFF		DSTC register
0x4006_2000	0x4006_3FFF		Reserved
0x4006_4000	0x4006_5FFF		Ethernet-MAC ch 0
0x4006_6000	0x4006_6FFF		Ethernet-MAC setting register
0x4006_7000	0x4006_BFFF		Reserved
0x4006_C000	0x4006_CFFF		I ² S
0x4006_D000	0x4006_DFFF		Reserved
0x4006_E000	0x4006_EFFF		SD card I/F
0x4006_F000	0x4006_FFFF		GPIO
0x4007_0000	0x4007_FFFF		Reserved
0x4008_0000	0x4008_0FFF		Programmable-CRC
0x4008_1000	0x41FF_FFFF		Reserved
0x200E_0000	0x200E_FFFF		Workflash I/F register
0xD000_0000	0xDFFF_FFFF		High-speed quad SPI control register

13. Pin Status In Each CPU State

The terms used for pin status have the following meanings:

- **INITX = 0**
This is the period when the INITX pin is at the "L" level.
- **INITX = 1**
This is the period when the INITX pin is at the "H" level.
- **SPL = 0**
This is the status that the standby pin level setting bit (SPL) in the standby mode control register (STB_CTL) is set to "0."
- **SPL = 1**
This is the status that the standby pin level setting bit (SPL) in the standby mode control register (STB_CTL) is set to "1."
- **Input enabled**
Indicates that the input function can be used.
- **Internal input fixed at 0**
This is the status that the input function cannot be used. Internal input is fixed at "L."
- **Hi-Z**
Indicates that the pin drive transistor is disabled and the pin is put in the Hi-Z state.
- **Setting disabled**
Indicates that the setting is disabled.
- **Maintain previous state**
Maintains the state that was immediately prior to entering the current mode.
If a built-in peripheral function is operating, the output follows the peripheral function.
If the pin is being used as a port, that output is maintained.
- **Analog input is enabled**
Indicates that the analog input is enabled.
- **Trace output**
Indicates that the trace function can be used.
- **GPIO selected**
In Deep standby mode, pins switch to the general-purpose I/O port.
- **Setting prohibition**
Prohibition of a setting by specification limitation

List of Pin Behavior By Mode State

Pin Status Type	Function Group	Power-On Reset or Low-Voltage Detection State	INITX Input State	Device Internal Reset State	Run Mode or Sleep Mode State	Timer Mode, RTC Mode, or Stop Mode State		Deep Standby RTC Mode or Deep Standby Stop Mode State		Return From Deep Standby Mode State
		Power Supply Unstable	Power Supply Stable		Power Supply Stable	Power Supply Stable		Power Supply Stable		Power Supply Stable
		-	INITX=0	INITX=1	INITX=1	INITX=1		INITX=1		INITX=1
		-	-	-	-	SPL=0	SPL=1	SPL=0	SPL=1	-
A	GPIO selected	Setting disabled	Setting disabled	Setting disabled	Maintain previous state	Maintain previous state	Hi-Z/internal input fixed at 0	GPIO selected, internal input fixed at 0	Hi-Z/internal input fixed at 0	GPIO selected
	Main crystal oscillator input pin/ external main clock input selected	Input enabled	Input enabled	Input enabled	Input enabled	Input enabled	Input enabled	Input enabled	Input enabled	Input Enabled
B	GPIO selected	Setting disabled	Setting disabled	Setting disabled	Maintain previous state	Maintain previous state	Hi-Z/internal input fixed at 0	GPIO selected, internal input fixed at 0	Hi-Z/internal input fixed at 0	GPIO selected
	External main clock input selected	Setting disabled	Setting disabled	Setting disabled	Maintain previous state	Maintain previous state	Hi-Z/internal input fixed at 0	Maintain previous state	Hi-Z/internal input fixed at 0	Maintain previous State
	Main crystal oscillator output pin	Hi-Z/ internal input fixed at 0/ or input enable	Hi-Z/ internal input fixed at 0	Hi-Z/ internal input fixed at 0	Maintain previous state while oscillator active/ When oscillation stops*1, it will be Hi-Z/ Internal input fixed at 0					
C	INITX input pin	Pull-up/ input enabled	Pull-up/ Input enabled	Pull-up/ Input enabled	Pull-up/ Input enabled	Pull-up/ Input enabled	Pull-up/ Input enabled	Pull-up/ Input enabled	Pull-up/ Input enabled	Pull-up/ Input enabled
D	Mode input pin	Input enabled	Input enabled	Input enabled	Input enabled	Input enabled	Input enabled	Input enabled	Input enabled	Input enabled
E	Mode input pin	Input enabled	Input enabled	Input enabled	Input enabled	Input enabled	Input enabled	Input enabled	Input enabled	Input enabled
	GPIO selected	Setting disabled	Setting disabled	Setting disabled	Maintain previous state	Maintain previous state	Hi-Z/ input enabled	GPIO selected	Hi-Z/ input enabled	GPIO selected

Pin Status Type	Function Group	Power-On Reset or Low-Voltage Detection State	INITX Input State	Device Internal Reset State	Run Mode or Sleep Mode State	Timer Mode, RTC Mode, or Stop Mode State		Deep Standby RTC Mode or Deep Standby Stop Mode State		Return From Deep Standby Mode State		
		Power Supply Unstable	Power Supply Stable		Power Supply Stable	Power Supply Stable		Power Supply Stable		Power Supply Stable		
		-	INITX=0	INITX=1	INITX=1	INITX=1		INITX=1		INITX=1		
		-	-	-	-	SPL=0	SPL=1	SPL=0	SPL=1	-		
F	NMIX selected	Setting disabled	Setting disabled	Setting disabled	Maintain previous state	Maintain previous state	Maintain previous state	WKUP input enabled	Hi-Z/ WKUP input enabled	Maintain previous state		
	Resource other than above selected	Hi-Z	Hi-Z/ input enabled	Hi-Z/ input enabled			Hi-Z/ internal input fixed at 0			GPIO selected		
	GPIO selected											
G	JTAG selected	Hi-Z	Pull-up/ input enabled	Pull-up/ input enabled	Maintain previous state	Maintain previous state	Maintain previous state	Maintain previous state	Maintain previous state	Maintain previous state		
	GPIO selected	Setting disabled	Setting disabled	Setting disabled			Hi-Z/ internal input fixed at 0			GPIO selected, internal input fixed at 0	Hi-Z/ internal input fixed at 0	GPIO selected
H	JTAG selected	Hi-Z	Pull-up/ input enabled	Pull-up/ input enabled	Maintain previous state	Maintain previous state	Maintain previous state	Maintain previous state	Maintain previous state	Maintain previous state		
	Resource other than above selected	Setting disabled	Setting disabled	Setting disabled			Hi-Z/Internal input fixed at 0			GPIO selected, internal input fixed at 0	Hi-Z/Internal input fixed at 0	GPIO selected
	GPIO selected											
I	Resource selected	Hi-Z	Hi-Z/ input enabled	Hi-Z/ input enabled	Maintain previous state	Maintain previous state	Hi-Z/Internal input fixed at 0	GPIO selected, internal input fixed at 0	Hi-Z/internal input fixed at 0	GPIO selected		
	GPIO selected											

Pin Status Type	Function Group	Power-On Reset or Low-Voltage Detection State	INITX Input State	Device Internal Reset State	Run Mode or Sleep Mode State	Timer Mode, RTC Mode, or Stop Mode State		Deep Standby RTC Mode or Deep Standby Stop Mode State		Return From Deep Standby Mode State	
		Power Supply Unstable	Power Supply Stable		Power Supply Stable	Power Supply Stable		Power Supply Stable		Power Supply Stable	
		-	INITX=0	INITX=1	INITX=1	INITX=1		INITX=1		INITX=1	
		-	-	-	-	SPL=0	SPL=1	SPL=0	SPL=1	-	
J	Analog output selected	Hi-Z	Hi-Z/ input enabled	Hi-Z/ input enabled	Maintain previous state	*2	*3	GPIO selected, internal input fixed at 0	Hi-Z/internal input fixed at 0	GPIO selected	
	External interrupt enable selected					Maintain previous state	Maintain previous state				
	Resource other than above selected						Hi-Z/internal input fixed at 0				
	GPIO selected										
K	External interrupt enable selected	Setting disabled	Setting disabled	Setting disabled	Maintain previous state	Maintain previous state	Maintain previous state	GPIO selected, internal input fixed at 0	Hi-Z/internal input fixed at 0	GPIO selected	
	Resource other than above selected	Hi-Z	Hi-Z/ input enabled	Hi-Z/ input enabled			Hi-Z/internal input fixed at 0				
	GPIO selected										
L	Analog input selected	Hi-Z	Hi-Z/ internal input fixed at 0/ analog input enabled	Hi-Z/ internal input fixed at 0/ analog input enabled	Hi-Z/ internal input fixed at 0/ analog input enabled	Hi-Z/ internal input fixed at 0/ analog input enabled	Hi-Z/ internal input fixed at 0/ analog input enabled	Hi-Z/ internal input fixed at 0/ analog input enabled	Hi-Z/ internal input fixed at 0/ analog input enabled	Hi-Z/ internal input fixed at 0/ analog input enabled	
	Resource other than above selected		Setting disabled	Setting disabled	Setting disabled	Maintain previous state	Maintain previous state	Hi-Z/internal input fixed at 0	GPIO selected, internal input fixed at 0	Hi-Z/internal input fixed at 0	GPIO selected
	GPIO selected										

Pin Status Type	Function Group	Power-On Reset or Low-Voltage Detection State	INITX Input State	Device Internal Reset State	Run Mode or Sleep Mode State	Timer Mode, RTC Mode, or Stop Mode State		Deep Standby RTC Mode or Deep Standby Stop Mode State		Return From Deep Standby Mode State
		Power Supply Unstable	Power Supply Stable		Power Supply Stable	Power Supply Stable		Power Supply Stable		Power Supply Stable
		-	INITX=0	INITX=1	INITX=1	INITX=1		INITX=1		INITX=1
		-	-	-	-	SPL=0	SPL=1	SPL=0	SPL=1	-
M	Analog input selected	Hi-Z	Hi-Z/ internal input fixed at 0/ analog input enabled	Hi-Z/ internal input fixed at 0/ analog input enabled	Hi-Z/ internal input fixed at 0/ analog input enabled	Hi-Z/ internal input fixed at 0/ analog input enabled	Hi-Z/ internal input fixed at 0/ analog input enabled	Hi-Z/ internal input fixed at 0/ analog input enabled	Hi-Z/ internal input fixed at 0/ analog input enabled	Hi-Z/ internal input fixed at 0/ analog input enabled
	External interrupt enable selected	Setting disabled	Setting disabled	Setting disabled	Maintain previous state	Maintain previous state	Maintain previous state	GPIO selected, internal input fixed at 0	Hi-Z/internal input fixed at 0	GPIO selected
	Resource other than above selected						Hi-Z/internal input fixed at 0			
GPIO selected										
N	Analog input selected	Hi-Z	Hi-Z/ internal input fixed at 0/ analog input enabled	Hi-Z/ internal input fixed at 0/ analog input enabled	Hi-Z/ internal input fixed at 0/ analog input enabled	Hi-Z/ internal input fixed at 0/ analog input enabled	Hi-Z/ internal input fixed at 0/ analog input enabled	Hi-Z/ internal input fixed at 0/ analog input enabled	Hi-Z/ internal input fixed at 0/ analog input enabled	Hi-Z/ internal input fixed at 0/ analog input enabled
	Trace selected	Setting disabled	Setting disabled	Setting disabled	Maintain previous state	Maintain previous state	Trace output	GPIO selected, internal input fixed at 0	Hi-Z/internal input fixed at 0	GPIO selected
	Resource other than above selected						Hi-Z/internal input fixed at 0			
GPIO selected										

Pin Status Type	Function Group	Power-On Reset or Low-Voltage Detection State	INITX Input State	Device Internal Reset State	Run Mode or Sleep Mode State	Timer Mode, RTC Mode, or Stop Mode State		Deep Standby RTC Mode or Deep Standby Stop Mode State		Return From Deep Standby Mode State
		Power Supply Unstable	Power Supply Stable		Power Supply Stable	Power Supply Stable		Power Supply Stable		Power Supply Stable
		-	INITX=0	INITX=1	INITX=1	INITX=1		INITX=1		INITX=1
		-	-	-	-	SPL=0	SPL=1	SPL=0	SPL=1	-
O	Analog input selected	Hi-Z	Hi-Z/ internal input fixed at 0/ analog input enabled	Hi-Z/ internal input fixed at 0/ analog input enabled	Hi-Z/ internal input fixed at 0/ analog input enabled	Hi-Z/ internal input fixed at 0/ analog input enabled	Hi-Z/ internal input fixed at 0/ analog input enabled	Hi-Z/ internal input fixed at 0/ analog input enabled	Hi-Z/ internal input fixed at 0/ analog input enabled	Hi-Z/ internal input fixed at 0/ analog input enabled
	Trace selected	Setting disabled	Setting disabled	Setting disabled	Maintain previous state	Maintain previous state	Trace output	GPIO selected, internal input fixed at 0	Hi-Z/internal input fixed at 0	GPIO selected
	External interrupt enable selected						Maintain previous state			
	Resource other than above selected						Hi-Z/internal input fixed at 0			
GPIO selected										
P	Analog input selected	Hi-Z	Hi-Z/ internal input fixed at 0/ analog input enabled	Hi-Z/ internal input fixed at 0/ analog input enabled	Hi-Z/ internal input fixed at 0/ analog input enabled	Hi-Z/ internal input fixed at 0/ analog input enabled	Hi-Z/ internal input fixed at 0/ analog input enabled	Hi-Z/ internal input fixed at 0/ analog input enabled	Hi-Z/ internal input fixed at 0/ analog input enabled	Hi-Z/ internal input fixed at 0/ analog input enabled
	WKUP enabled	Setting disabled	Setting disabled	Setting disabled	Maintain previous state	Maintain previous state	Maintain previous state	WKUP input enabled	Hi-Z/ WKUP input enabled	GPIO selected
	Resource other than above selected						Hi-Z/internal input fixed at 0	GPIO selected, internal input fixed at 0	Hi-Z/internal input fixed at 0	
GPIO selected										

Pin Status Type	Function Group	Power-On Reset or Low-Voltage Detection State	INITX Input State	Device Internal Reset State	Run Mode or Sleep Mode State	Timer Mode, RTC Mode, or Stop Mode State		Deep Standby RTC Mode or Deep Standby Stop Mode State		Return From Deep Standby Mode State
		Power Supply Unstable	Power Supply Stable		Power Supply Stable	Power Supply Stable		Power Supply Stable		Power Supply Stable
		-	INITX=0	INITX=1	INITX=1	INITX=1		INITX=1		INITX=1
		-	-	-	-	SPL=0	SPL=1	SPL=0	SPL=1	-
Q	WKUP enabled	Setting disabled	Setting disabled	Setting disabled	Maintain previous state	Maintain previous state	Maintain previous state	WKUP input enabled	Hi-Z/ WKUP input enabled	WKUP input enabled
	External interrupt enable selected							GPIO selected, internal input fixed at 0	Hi-Z/internal input fixed at 0	GPIO selected
	Resource other than above selected	Hi-Z	Hi-Z/ input enabled	Hi-Z/ input enabled			Hi-Z/internal input fixed at 0			
	GPIO selected									
R	GPIO selected	Hi-Z	Hi-Z/ input enabled	Hi-Z/ input enabled	Maintain previous state	Maintain previous state	Hi-Z/internal input fixed at 0	GPIO selected, internal input fixed at 0	Hi-Z/internal input fixed at 0	GPIO selected
	USB I/O pin	Setting disabled	Setting disabled	Setting disabled	Hi-Z at transmission/ input enabled/ internal input fixed at 0 at reception	Hi-Z at transmission/ input enabled/ internal input fixed at 0 at reception	Hi-Z at transmission/ input enabled/ internal input fixed at 0 at reception	Hi-Z/ input enabled	Hi-Z/ input enabled	Hi-Z/ input enabled
V	Ethernet I/O selected *4	Setting disabled	Setting disabled	Setting disabled	Maintain previous state	Maintain previous state	Maintain previous state	GPIO selected, internal input fixed at 0	Hi-Z/internal input fixed at "0	GPIO selected
	Resource other than above selected	Hi-Z	Hi-Z/ input enabled	Hi-Z/ input enabled			Hi-Z/internal input fixed at 0			
	GPIO selected									

Pin Status Type	Function Group	Power-On Reset or Low-Voltage Detection State	INITX Input State	Device Internal Reset State	Run Mode or Sleep Mode State	Timer Mode, RTC Mode, or Stop Mode State		Deep Standby RTC Mode or Deep Standby Stop Mode State		Return From Deep Standby Mode State
		Power Supply Unstable	Power Supply Stable		Power Supply Stable	Power Supply Stable		Power Supply Stable		Power Supply Stable
		-	INITX=0	INITX=1	INITX=1	INITX=1		INITX=1		INITX=1
		-	-	-	-	SPL=0	SPL=1	SPL=0	SPL=1	-
W	Ethernet input/output selected ⁴	Setting disabled	Setting disabled	Setting disabled	Maintain previous state	Maintain previous state	Maintain previous state	GPIO selected, internal input fixed at 0	Hi-Z/internal input fixed at 0	GPIO selected
	External interrupt enable selected									
	Resource other than above selected	Hi-Z	Hi-Z/ input enabled	Hi-Z/ input enabled						
	GPIO selected									
X	CEC enabled	Setting disabled	Setting disabled	Setting disabled	Maintain previous state	Maintain previous state	Maintain previous state	GPIO selected, internal input fixed at 0	Hi-Z/internal input fixed at 0	GPIO selected
	External interrupt enable selected									
	Resource other than above selected	Hi-Z	Hi-Z/ input enabled	Hi-Z/ input enabled						
	GPIO selected									

Pin Status Type	Function Group	Power-On Reset or Low-Voltage Detection State	INITX Input State	Device Internal Reset State	Run Mode or Sleep Mode State	Timer Mode, RTC Mode, or Stop Mode State		Deep Standby RTC Mode or Deep Standby Stop Mode State		Return From Deep Standby Mode State			
		Power Supply Unstable	Power Supply Stable		Power Supply Stable	Power Supply Stable		Power Supply Stable		Power Supply Stable			
		-	INITX=0	INITX=1	INITX=1	INITX=1		INITX=1		INITX=1			
		-	-	-	-	SPL=0	SPL=1	SPL=0	SPL=1	-			
Y	CEC enabled	Setting disabled	Setting disabled	Setting disabled	Maintain previous state	Maintain previous state	Maintain previous state	Maintain previous state	Maintain previous state	Maintain previous state			
	WKUP enabled							WKUP input enabled	Hi-Z/ WKUP input enabled	GPIO selected			
	External interrupt enable selected							GPIO selected, internal input fixed at 0	Hi-Z/internal input fixed at 0				
	Resource other than above selected										Hi-Z	Hi-Z/ input enabled	Hi-Z/ input enabled
	GPIO selected												

- 1 : Oscillation is stopped at sub timer mode, sub CR timer mode, RTC mode, Stop mode, Deep standby RTC mode, and Deep standby Stop mode.
- 2 : Maintain previous state at timer mode. GPIO selected internal input fixed at 0 at RTC mode, Stop mode.
- 3 : Maintain previous state at timer mode. Hi-Z/internal input fixed at 0 at RTC mode, Stop mode.
- 4 : It shows the case selected by EPFR14.E_SPLC register.

List of VBAT Domain Pin Status

VBAT Pin Status Type	Function Group	VBAT Power-On Reset	INITX Input State	Device Internal Reset State	Run Mode or Sleep Mode State	Timer Mode, RTC Mode, or Stop Mode State		Deep Standby RTC Mode or Deep Standby Stop Mode State		Return From Deep Standby Mode State	VBAT RTC Mode State	Return From VBAT RTC Mode State
		Power Supply Unstable	Power Supply Stable		Power Supply Stable	Power Supply Stable		Power Supply Stable		Power Supply Stable	Power Supply Stable	Power Supply Stable
		-	INITX=0	INITX=1	INITX=1	INITX=1		INITX=1		INITX=1	-	-
		-	-	-	-	SPL=0	SPL=1	SPL=0	SPL=1	-	-	-
S	GPIO selected	Setting disabled	Maintain previous state	Maintain previous state	Maintain previous state	Maintain previous state	Maintain previous state	Maintain previous state	Maintain previous state	Maintain previous state	Setting prohibition	-
	Sub crystal oscillator input pin/ external sub clock input selected	Input enabled	Input enabled	Input enabled	Input enabled	Input enabled	Input enabled	Input enabled	Input enabled	Input enabled	Maintain previous state	Maintain previous state
T	GPIO selected	Setting disabled	Maintain previous state	Maintain previous state	Maintain previous state	Maintain previous state	Maintain previous state	Maintain previous state	Maintain previous state	Maintain previous state	Setting prohibition	-
	External sub clock input selected	Setting disabled	Maintain previous state	Maintain previous state	Maintain previous state	Maintain previous state	Maintain previous state	Maintain previous state	Maintain previous state	Maintain previous state	Maintain previous state	Maintain previous state
	Sub crystal oscillator fixed at 0/ output pin or input enable	Hi-Z/ internal input	Maintain previous state	Maintain previous state	Maintain previous state	Maintain previous state/ When oscillation stops, Hi-Z*	Maintain previous state/ When oscillation stops, Hi-Z*	Maintain previous state/ When oscillation stops, Hi-Z*	Maintain previous state/ When oscillation stops, Hi-Z*	Maintain previous state	Maintain previous state	Maintain previous state
U	Resource selected	Hi-Z	Maintain previous state	Maintain previous state	Maintain previous state	Maintain previous state	Maintain previous state	Maintain previous state	Maintain previous state	Maintain previous state	Maintain previous state	Maintain previous state
	GPIO selected		Maintain previous state	Maintain previous state	Maintain previous state	Maintain previous state	Maintain previous state	Maintain previous state	Maintain previous state	Maintain previous state	Maintain previous state	Maintain previous state

* : When the SOSCNTL bit in the WTOSCCNT register is 0, the sub crystal oscillator output pin is maintained in the previous state. When the SOSCNTL bit in the WTOSCCNT register is 1, oscillation is stopped at Stop mode and Deep standby Stop mode

14. Electrical Characteristics

14.1 Absolute Maximum Ratings

Parameter	Symbol	Rating		Unit	Remarks
		Min	Max		
Power supply voltage ^{*1,*2}	V _{CC}	V _{SS} - 0.5	V _{SS} + 6.5	V	
Power supply voltage (for USB) ^{*1,*3}	USBV _{CC0}	V _{SS} - 0.5	V _{SS} + 6.5	V	
Power supply voltage (for USB) ^{*1,*3}	USBV _{CC1}	V _{SS} - 0.5	V _{SS} + 6.5	V	
Power supply voltage (for Ethernet-MAC) ^{*1,*4}	ETHV _{CC}	V _{SS} - 0.5	V _{SS} + 6.5	V	
Power supply voltage (VBAT) ^{*1,*5}	V _{BAT}	V _{SS} - 0.5	V _{SS} + 6.5	V	
Analog power supply voltage ^{*1,*6}	AV _{CC}	V _{SS} - 0.5	V _{SS} + 6.5	V	
Analog reference voltage ^{*1,*6}	AVRH	V _{SS} - 0.5	V _{SS} + 6.5	V	
Input voltage ^{*1}	V _I	V _{SS} - 0.5	V _{CC} + 0.5 (≤ 6.5V)	V	Except for USB and Ethernet-MAC pin
		V _{SS} - 0.5	USBV _{CC0} + 0.5 (≤ 6.5V)	V	USB ch 0 pin
		V _{SS} - 0.5	USBV _{CC1} + 0.5 (≤ 6.5V)	V	USB ch 1 pin
		V _{SS} - 0.5	ETHV _{CC} + 0.5 (≤ 6.5V)	V	Ethernet-MAC Pin
		V _{SS} - 0.5	V _{SS} + 6.5	V	5V tolerant
Analog pin input voltage ^{*1}	V _{IA}	V _{SS} - 0.5	AV _{CC} + 0.5 (≤ 6.5V)	V	
Output voltage ^{*1}	V _O	V _{SS} - 0.5	V _{CC} + 0.5 (≤ 6.5V)	V	
"L" level maximum output current ^{*7}	I _{OL}	-	10	mA	4 mA type
			20	mA	8 mA type
			20	mA	12 mA type
			22.4	mA	I ² C Fm+
"L" level average output current ^{*8}	I _{OLAV}	-	4	mA	4 mA type
			8	mA	8 mA type
			12	mA	12 mA type
			20	mA	I ² C Fm+
"L" level total maximum output current	∑I _{OL}	-	100	mA	
"L" level total maximum output current ^{*9}	∑I _{OLAV}	-	50	mA	
"H" level maximum output current ^{*7}	I _{OH}	-	- 10	mA	4 mA type
			-20	mA	8 mA type
			- 20	mA	12 mA type
"H" level average output current ^{*8}	I _{OHAV}	-	- 4	mA	4 mA type
			-8	mA	8 mA type
			- 12	mA	12 mA type
"H" level total maximum output current	∑I _{OH}	-	- 100	mA	
"H" level total average output current ^{*9}	∑I _{OHAV}	-	- 50	mA	
Power consumption	P _D	-	200	mW	
Storage temperature	T _{STG}	- 55	+ 150	°C	

1 : These parameters are based on the condition that V_{SS} = AV_{SS} = 0.0V.

2 : V_{CC} must not drop below V_{SS} - 0.5V.

3 : USBV_{CC0}, USBV_{CC1} must not drop below V_{SS} - 0.5V.

4 : ETHV_{CC} must not drop below V_{SS} - 0.5V.

5 : V_{BAT} must not drop below V_{SS} - 0.5V.

- 6 : Ensure that the voltage does not exceed $V_{CC} + 0.5V$, for example, when the power is turned on.
- 7 : The maximum output current is defined as the value of the peak current flowing through any one of the corresponding pins.
- 8 : The average output current is defined as the average current value flowing through any one of the corresponding pins for a 100-ms period.
- 9 : The total average output current is defined as the average current value flowing through all of corresponding pins for a 100-ms period.

WARNING:

- *Semiconductor devices may be permanently damaged by application of stress (including, without limitation, voltage, current or temperature) in excess of absolute maximum ratings. Do not exceed any of these ratings.*

14.2 Recommended Operating Conditions

Parameter	Symbol	Conditions	Value		Unit	Remarks
			Min	Max		
Power supply voltage	V _{CC}	-	2.7 ^{*9}	5.5	V	
Power supply voltage (for USB ch 0)	USBV _{CC0}	-	3.0	3.6 (≤V _{CC})	V	*1
			2.7	5.5 (≤V _{CC})		*2
Power supply voltage (for USB ch 1)	USBV _{CC1}	-	3.0	3.6 (≤V _{CC})	V	*3
			2.7	5.5 (≤V _{CC})		*4
Power supply voltage (for Ethernet-MAC)	ETHV _{CC}	-	3.0	3.6 (≤V _{CC})	V	*5
			4.5	5.5 (≤V _{CC})		*5
			2.7	5.5 (≤V _{CC})		*6
Power supply voltage (VBAT)	V _{BAT}	-	1.65	5.5	V	
Analog power supply voltage	AV _{CC}	-	2.7	5.5	V	AV _{CC} = V _{CC}
Analog reference voltage	AVRH	-	*8	AV _{CC}	V	
Operating temperature	Junction temperature	T _j	- 40	+ 125	°C	
	Ambient temperature	T _a	-40	*7	°C	

1 : When P81/UDP0 and P80/UDM0 pins are used as USB (UDP0, UDM0)

2 : When P81/UDP0 and P80/UDM0 pins are used as GPIO (P81, P80)

3 : When P83/UDP1 and P82/UDM1 pins are used as USB (UDP1, UDM1)

4 : When P83/UDP1 and P82/UDM1 pins are used as GPIO (P83, P82)

5 : When the pins in "Ethernet-MAC Pins," except P6E/ADTG_5/SCK4_1/IC23_1/INT29_0/E_PPS pin, are used as Ethernet-MAC pin

6 : When the pins in "Ethernet-MAC Pins," except P6E/ADTG_5/SCK4_1/IC23_1/INT29_0/E_PPS pin, are used as Ethernet-MAC pin

7 : The maximum temperature of the ambient temperature (T_a) can guarantee a range that does not exceed the junction temperature (T_j).

The calculation formula of the ambient temperature (T_a) is:

$$T_a(\text{Max}) = T_j(\text{Max}) - P_d(\text{Max}) \times \theta_{ja}$$

P_d : Power dissipation (W)

θ_{ja} : Package thermal resistance (°C/W)

$$P_d(\text{Max}) = V_{CC} \times I_{CC}(\text{Max}) + \sum (I_{OL} \times V_{OL}) + \sum ((V_{CC} - V_{OH}) \times (-I_{OH}))$$

I_{OL} : "L" level output current

I_{OH} : "H" level output current

V_{OL} : "L" level output voltage

V_{OH} : "H" level output voltage

8 : The minimum value of analog reference voltage depends on the value of compare clock cycle (T_{ck}). See "14.5. 12-bit A/D Converter" for the details.

9 : For the voltage range between V_{cc(min)} and the low voltage detection reset (VDH), the MCU must be clocked from either the high-speed CR or the low-speed CR."

Package thermal resistance and maximum permissible power for each package are shown below. The operation is guaranteed maximum permissible power or less for semiconductor devices.

Table 14-1 Table For Package Thermal Resistance and Maximum Permissible Power

Package	Printed Circuit Board	Thermal Resistance θ_{ja} (°C/W)	Maximum Permissible Power (mW)	
			Ta = +85°C	Ta = +105°C
FPT-144P-M08 (0.5-mm pitch)	Single-layered both sides	48	833	417
	4 layers	33	1212	606
FPT-176P-M07 (0.5-mm pitch)	Single-layered both sides	45	889	444
	4 layers	31	1290	645
FPT-216P-M01 (0.4-mm pitch)	Single-layered both sides	46	870	435
	4 layers	32	1250	625
LBE192 (0.8-mm pitch)	Single-layered both sides	-	-	-
	4 layers	35	1143	571

WARNING:

1. The recommended operating conditions are required in order to ensure the normal operation of the semiconductor device. All of the device's electrical characteristics are warranted when the device is operated within these ranges.
2. Always use semiconductor devices within their recommended operating condition ranges. Operation outside these ranges may adversely affect reliability and could result in device failure.
3. No warranty is made with respect to uses, operating conditions, or combinations not represented on the data sheet.
4. Users considering application outside the listed conditions are advised to contact their representatives beforehand.

Ethernet-MAC Pins

Pin Name	Ethernet-MAC Function	Except For Ethernet-MAC Function	Power Supply Type
P6E/ADTG_5/SCK4_1/IC23_1/INT29_0/E_PPS	E_PPS *	P6E/ADTG_5/SCK4_1/IC23_1/INT29_0	V _{CC}
PC0/E_RXER	E_RX03	PC0	ETHV _{CC}
PC1/TIOB6_0/E_RX03	E_RX02	PC1/TIOB6_0	
PC2/TIOA6_0/E_RX02	E_RX01	PC2/TIOA6_0	
PC3/TIOB7_0/E_RX01	E_RX00	PC3/TIOB7_0	
PC4/TIOA7_0/E_RX00	E_RXDV	PC4/TIOA7_0	
PC5/TIOB14_0/E_RXDV	E_MDIO	PC5/TIOB14_0	
PC6/TIOA14_0/E_MDIO	E_MDC	PC6/TIOA14_0	
PC7/INT13_0/E_MDC/CROUT_1	E_RXCK_REFCK	PC7/INT13_0/CROUT_1	
PC8/E_RXCK_REFCK	E_COL	PC8	
PC9/TIOB15_0/E_COL	E_CRS	PC9/TIOB15_0	
PCA/TIOA15_0/E_CRS	E_COUT	PCA/TIOA15_0	
PCB/INT28_0/E_COUT	E_TCK	PCB/INT28_0	
PCC/E_TCK	E_TXER	PCC	
PCD/SOT4_1/INT14_0/E_TXER	E_TX03	PCD/SOT4_1/INT14_0	
PCE/SIN4_1/INT15_0/E_TX03	E_TX02	PCE/SIN4_1/INT15_0	
PCF/RTS4_1/INT12_0/E_TX02	E_TX01	PCF/RTS4_1/INT12_0	
PD0/INT30_1/E_TX01	E_TX00	PD0/INT30_1	
PD1/INT31_1/E_TX00	E_TXEN	PD1/INT31_1	
PD2/CTS4_1/FRCK2_1/E_TXEN	E_RX03	PD2/CTS4_1/FRCK2_1	

* : It is used to confirm the PTP counter cycle in Ethernet-MAC by waveforms.

Calculation Method of Power Dissipation (Pd)

The power dissipation is shown in the following formula.

$$Pd = V_{CC} \times I_{CC} + \sum (I_{OL} \times V_{OL}) + \sum ((V_{CC}-V_{OH}) \times (-I_{OH}))$$

I_{OL} : "L" level output current
 I_{OH} : "H" level output current
 V_{OL} : "L" level output voltage
 V_{OH} : "H" level output voltage

I_{CC} is the current drawn by the device.
 It can be analyzed as follows.

$$I_{CC} = I_{CC} (INT) + \sum I_{CC} (IO)$$

$I_{CC} (INT)$: Current drawn by internal logic and memory, etc. through the regulator

$\sum I_{CC} (IO)$: Sum of current (I/O switching current) drawn by the output pin

For $I_{CC} (INT)$, it can be anticipated by "(1) Current Rating" in "14.3. DC Characteristics" (This rating value does not include $I_{CC} (IO)$ for a value at pin fixed).

For $I_{CC} (IO)$, it depends on system used by customers.

The calculation formula is shown below.

$$I_{CC} (IO) = (C_{INT} + C_{EXT}) \times V_{CC} \times f_{SW}$$

C_{INT} : Pin internal load capacitance
 C_{EXT} : External load capacitance of output pin
 f_{SW} : Pin switching frequency

Parameter	Symbol	Conditions	Capacitance Value
Pin internal load capacitance	C_{INT}	4 mA type	1.93 pF
		8 mA type	3.45 pF
		12 mA type	3.42 pF

Calculate $I_{CC} (Max)$ as follows when the power dissipation can be evaluated by yourself:

Measure current value $I_{CC} (Typ)$ at normal temperature (+25°C).

Add maximum leakage current value $I_{CC} (leak_max)$ at operating on a value in (1).

$$I_{CC}(Max) = I_{CC} (Typ) + I_{CC} (leak_max)$$

Parameter	Symbol	Conditions	Current Value
Maximum leakage current at operating	$I_{CC} (leak_max)$	$T_j = +125^\circ C$	TBD
		$T_j = +105^\circ C$	TBD
		$T_j = +85^\circ C$	TBD

Current Explanation Diagram

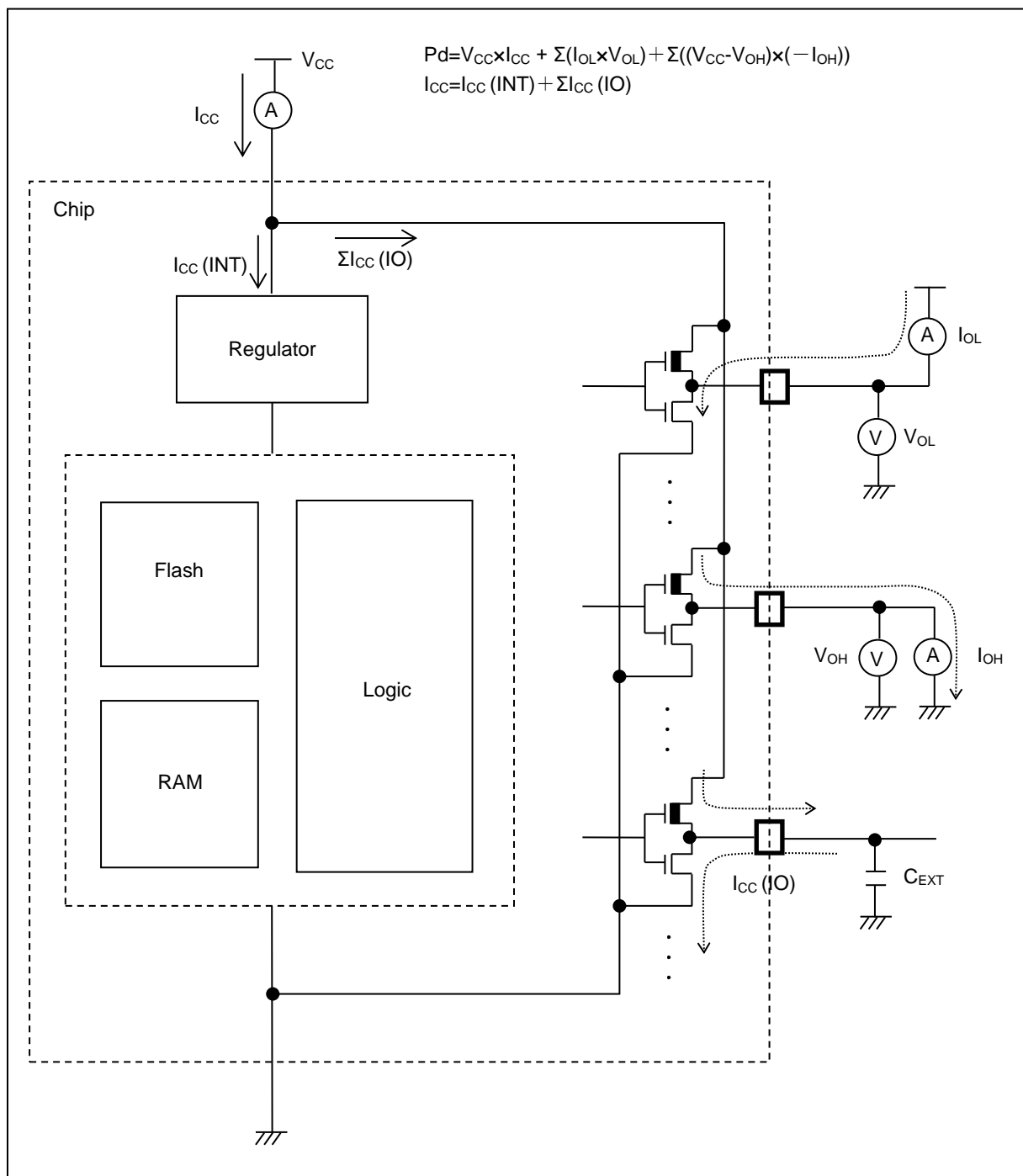

14.3 DC Characteristics

14.3.1 Current Rating

Table 14-2 Typical and maximum current consumption in Normal operation(PLL), code running from Flash memory (Flash accelerator mode and trace buffer function enabled)

Parameter	Symbol	Pin Name	Conditions	Frequency* ⁴	Value		Unit	Remarks		
					Typ* ¹	Max* ²				
Power supply current	I _{CC}	VCC	Normal operation * ⁷ ,* ⁸ (PLL)	* ⁵	200 MHz	119	180	mA	* ³ When all peripheral clocks are on	
					192 MHz	115	TBD	mA		
					180 MHz	108	TBD	mA		
				* ⁶	160 MHz	98	TBD	mA		
					144 MHz	89	TBD	mA		
					120 MHz	75	TBD	mA		
					100 MHz	64	TBD	mA		
					80 MHz	52	TBD	mA		
					60 MHz	40	TBD	mA		
					40 MHz	28	TBD	mA		
					20 MHz	16	TBD	mA		
					8 MHz	8.9	TBD	mA		
				4 MHz	6.5	TBD	mA			
				* ⁵	200 MHz	73	TBD	mA	* ³ When all peripheral clocks are off	
					192 MHz	70	TBD	mA		
					180 MHz	66	TBD	mA		
					* ⁶	160 MHz	61	TBD		mA
						144 MHz	55	TBD		mA
						120 MHz	47	TBD		mA
						100 MHz	40	TBD		mA
						80 MHz	33	TBD		mA
						60 MHz	26	TBD		mA
						40 MHz	18	TBD		mA
						20 MHz	11	TBD		mA
8 MHz	6.5	TBD	mA							
4 MHz	5.1	TBD	mA							

1 : Ta = +25°C, V_{CC} = 3.3V

2 : Tj = +125°C, V_{CC} = 5.5V

3 : When all ports are fixed

4 : Frequency is a value of HCLK when PCLK0 = PCLK1 = PCLK2 = HCLK

5 : When stopping flash accelerator mode and trace buffer function (FRWTR.RWT = 11, FBFCR.BE = 1)

6 : When stopping flash accelerator mode and trace buffer function (FRWTR.RWT = 10, FBFCR.BE = 1)

7 : Firmware being executed during data collection for this table is not being accessed from the MainFlash memory.”

8 : When using the crystal oscillator of 4 MHz (including the current consumption of the oscillation circuit)

Table 14-2 Typical and maximum current consumption in Normal operation(PLL), code with data accessing running from Flash memory (Flash accelerator mode and trace buffer function disabled)

Parameter	Symbol	Pin Name	Conditions	Frequency* ⁴	Value		Unit	Remarks		
					Typ* ¹	Max* ²				
Power supply current	I _{CC}	VCC	Normal operation *7,*8 (PLL)	*5	200 MHz	128	220	mA	*3 When all peripheral clocks are on	
					192 MHz	123	TBD	mA		
					180 MHz	116	TBD	mA		
				*6	160 MHz	102	TBD	mA		
					144 MHz	93	TBD	mA		
					120 MHz	79	TBD	mA		
					100 MHz	67	TBD	mA		
					80 MHz	54	TBD	mA		
					60 MHz	42	TBD	mA		
					40 MHz	30	TBD	mA		
				*5	200 MHz	74	TBD	mA		*3 When all peripheral clocks are off
					192 MHz	71	TBD	mA		
					180 MHz	67	TBD	mA		
				*6	160 MHz	59	TBD	mA		
					144 MHz	53	TBD	mA		
					120 MHz	45	TBD	mA		
					100 MHz	39	TBD	mA		
					80 MHz	32	TBD	mA		
					60 MHz	25	TBD	mA		
					40 MHz	18	TBD	mA		
20 MHz	11	TBD	mA							
*6	8 MHz	6.5	TBD	mA						
	4 MHz	5.1	TBD	mA						

1 : Ta = +25°C, V_{CC} = 3.3V

2 : Tj = +125°C, V_{CC} = 5.5V

3 : When all ports are fixed

4 : Frequency is a value of HCLK when PCLK0 = PCLK1 = PCLK2 = HCLK

5 : When stopping flash accelerator mode and trace buffer function (FRWTR.RWT = 11, FBFCR.BE = 0)

6 : When stopping flash accelerator mode and trace buffer function (FRWTR.RWT = 10, FBFCR.BE = 0)

7 : With data access to a MainFlash memory.

8 : When using the crystal oscillator of 4 MHz (including the current consumption of the oscillation circuit)

Table 14-3 Typical and maximum current consumption in Normal operation(PLL), code with data accessing running from Flash memory (flash 0 wait-cycle mode and read access 0 wait)

Parameter	Symbol	Pin Name	Conditions	Frequency* ⁴	Value		Unit	Remarks	
					Typ* ¹	Max* ²			
Power supply current	I _{CC}	VCC	Normal operation *6,*7 (PLL)	*5	72 MHz	71	TBD	mA	*3 When all peripheral clocks are on
					60 MHz	62	TBD	mA	
					48 MHz	51	TBD	mA	
					36 MHz	40	TBD	mA	
					24 MHz	29	TBD	mA	
					12 MHz	17	TBD	mA	
					8 MHz	13	TBD	mA	
					4 MHz	8.4	TBD	mA	
				*5	72 MHz	46	TBD	mA	*3 When all peripheral clocks are off
					60 MHz	41	TBD	mA	
					48 MHz	34	TBD	mA	
					36 MHz	27	TBD	mA	
					24 MHz	20	TBD	mA	
					12 MHz	12	TBD	mA	
8 MHz	9.4	TBD	mA						
4 MHz	6.5	TBD	mA						

1 : Ta = +25°C, V_{CC} = 3.3V

2 : Tj = +125°C, V_{CC} = 5.5V

3 : When all ports are fixed

4 : Frequency is a value of HCLK when PCLK0 = PCLK1 = PCLK2 = HCLK

5 : When operating flash 0 wait-cycle mode and read access 0 wait (FRWTR.RWT = 00, FBFCR.SD = 000)

6 : With data access to a MainFlash memory.

7 : When using the crystal oscillator of 4 MHz (including the current consumption of the oscillation circuit)

Table 14-4 Typical and maximum current consumption in Normal operation(other than PLL), code with data accessing running from Flash memory (flash 0 wait-cycle mode and read access 0 wait)

Parameter	Symbol	Pin Name	Conditions		Frequency* ⁴	Value		Unit	Remarks
						Typ* ¹	Max* ²		
Power supply current	I _{cc}	VCC	Normal operation * ⁶ (built-in high-speed CR)	* ⁵	4 MHz	3.0	TBD	mA	* ³ When all peripheral clocks are on
						2.1	TBD	mA	* ³ When all peripheral clocks are off
			Normal operation * ⁶ , * ⁷ (sub oscillation)	* ⁵	32 kHz	0.78	TBD	mA	* ³ When all peripheral clocks are on
						0.77	TBD	mA	* ³ When all peripheral clocks are off
			Normal operation * ⁶ (built-in low-speed CR)	* ⁵	100 kHz	0.81	TBD	mA	* ³ When all peripheral clocks are on
						0.78	TBD	mA	* ³ When all peripheral clocks are off

1 : Ta = +25°C, V_{CC} = 3.3V

2 : Tj = +125°C, V_{CC} = 5.5V

3 : When all ports are fixed

4 : Frequency is a value of HCLK when PCLK0 = PCLK1 = PCLK2 = HCLK/2

5 : When operating flash 0 wait-cycle mode and read access 0 wait (FRWTR.RWT = 00, FBFCR.SD = 000)

6 : With data access to a MainFlash memory.

7 : When using the crystal oscillator of 32kHz (including the current consumption of the oscillation circuit)

Table 14-5 Typical and maximum current consumption in Sleep operation(PLL), when PCLK0 = PCLK1 = PCLK2 = HCLK/2

Parameter	Symbol	Pin Name	Conditions	Frequency* ⁴	Value		Unit	Remarks
					Typ* ¹	Max* ²		
Power supply current	I _{CCS}	VCC	Sleep operation * ⁵ (PLL)	200 MHz	88	TBD	mA	* ³ When all peripheral clocks are on
				192 MHz	85	TBD	mA	
				180 MHz	80	TBD	mA	
				160 MHz	72	TBD	mA	
				144 MHz	65	TBD	mA	
				120 MHz	55	TBD	mA	
				100 MHz	47	TBD	mA	
				80 MHz	38	TBD	mA	
				60 MHz	30	TBD	mA	
				40 MHz	21	TBD	mA	
				20 MHz	12	TBD	mA	
				8 MHz	7.4	TBD	mA	
				4 MHz	5.8	TBD	mA	
				200 MHz	44	TBD	mA	* ³ When all peripheral clocks are off
				192 MHz	42	TBD	mA	
				180 MHz	40	TBD	mA	
				160 MHz	36	TBD	mA	
				144 MHz	33	TBD	mA	
				120 MHz	28	TBD	mA	
				100 MHz	24	TBD	mA	
80 MHz	20	TBD	mA					
60 MHz	16	TBD	mA					
40 MHz	12	TBD	mA					
20 MHz	7.6	TBD	mA					
8 MHz	5.2	TBD	mA					
4 MHz	4.4	TBD	mA					

1 : Ta = +25°C, V_{CC} = 3.3V

2 : Tj = +125°C, V_{CC} = 5.5V

3 : When all ports are fixed

4 : Frequency is a value of HCLK when PCLK0 = PCLK1 = PCLK2 = HCLK/2

5 : When using the crystal oscillator of 4 MHz (including the current consumption of the oscillation circuit)

Table 14-6 Typical and maximum current consumption in Sleep operation(PLL), when PCLK0 = PCLK1 = PCLK2 = HCLK

Parameter	Symbol	Pin Name	Conditions	Frequency* ⁴	Value		Unit	Remarks
					Typ* ¹	Max* ²		
Power supply current	I _{CCS}	VCC	Sleep operation* ⁵ (PLL)	72 MHz	45	TBD	mA	* ³ When all peripheral clocks are on
				60 MHz	38	TBD	mA	
				48 MHz	31	TBD	mA	
				36 MHz	24	TBD	mA	
				24 MHz	18	TBD	mA	
				12 MHz	11	TBD	mA	
				8 MHz	8.6	TBD	mA	
				4 MHz	6.3	TBD	mA	
				72 MHz	20	TBD	mA	* ³ When all peripheral clocks are off
				60 MHz	18	TBD	mA	
				48 MHz	15	TBD	mA	
				36 MHz	12	TBD	mA	
				24 MHz	9.1	TBD	mA	
				12 MHz	6.5	TBD	mA	
8 MHz	5.5	TBD	mA					
4 MHz	4.6	TBD	mA					

1 : Ta = +25°C, V_{CC} = 3.3V

2 : Tj = +125°C, V_{CC} = 5.5V

3 : When all ports are fixed

4 : Frequency is a value of HCLK when PCLK0 = PCLK1 = PCLK2 = HCLK

5 : When using the crystal oscillator of 4 MHz (including the current consumption of the oscillation circuit)

Table 14-7 Typical and maximum current consumption in Sleep operation(other than PLL), when PCLK0 = PCLK1 = PCLK2 = HCLK/2

Parameter	Symbol	Pin Name	Conditions	Frequency* ⁴	Value		Unit	Remarks
					Typ* ¹	Max* ²		
Power supply current	I _{CCS}	VCC	Sleep operation (built-in high-speed CR)	4 MHz	2.5	TBD	mA	*3 When all peripheral clocks are on
					1.7	TBD	mA	*3 When all peripheral clocks are off
			Sleep operation * ⁵ (sub oscillation)	32 kHz	0.75	TBD	mA	*3 When all peripheral clocks are on
					0.74	TBD	mA	*3 When all peripheral clocks are off
			Sleep operation (built-in low-speed CR)	100 kHz	0.79	TBD	mA	*3 When all peripheral clocks are on
					0.76	TBD	mA	*3 When all peripheral clocks are off

1 : Ta = +25°C, V_{CC} = 3.3V

2 : Tj = +125°C, V_{CC} = 5.5V

3 : When all ports are fixed.

4 : Frequency is a value of HCLK when PCLK0 = PCLK1 = PCLK2 = HCLK/2

5 : When using the crystal oscillator of 32 MHz (including the current consumption of the oscillation circuit)

Table 14-8 Typical and maximum current consumption in STOP mode, TIMER mode and RTC mode

Parameter	Symbol	Pin Name	Conditions	Frequency	Value		Unit	Remarks
					Typ ^{*1}	Max ^{*2}		
Power supply current	I _{CCH}	VCC	Stop mode	-	0.56	TBD	mA	*3, *4 Ta = +25°C
					-	TBD	mA	*3, *4 Ta = +85°C
					-	TBD	mA	*3, *4 Ta = +105°C
	I _{CCR}		Timer mode (built-in high-speed CR)	4 MHz	1.43	TBD	mA	*3, *4 Ta = +25°C
					-	TBD	mA	*3, *4 Ta = +85°C
					-	TBD	mA	*3, *4 Ta = +105°C
			Timer mode ^{*5} (sub oscillation)	32 kHz	0.57	TBD	mA	*3, *4 Ta = +25°C
					-	TBD	mA	*3, *4 Ta = +85°C
					-	TBD	mA	*3, *4 Ta = +105°C
			Timer mode (built-in low-speed CR)	100 kHz	0.58	TBD	mA	*3, *4 Ta = +25°C
					-	TBD	mA	*3, *4 Ta = +85°C
					-	TBD	mA	*3, *4 Ta = +105°C
	I _{CCR}		RTC mode ^{*5} (sub oscillation)	32 kHz	0.57	TBD	mA	*3, *4 Ta = +25°C
					-	TBD	mA	*3, *4 Ta = +85°C
					-	TBD	mA	*3, *4 Ta = +105°C

1 : V_{CC} = 3.3V2 : V_{CC} = 5.5V

3 : When all ports are fixed

4 : When LVD is off

5 : When using the crystal oscillator of 32 MHz (including the current consumption of the oscillation circuit)

Table 14-9 Typical and maximum current consumption in Deep Standby STOP mode, Deep Standby RTC mode and VBAT

Parameter	Symbol	Pin Name	Conditions	Frequency	Value		Unit	Remarks
					Typ* ¹	Max* ²		
Power supply current	I _{CCHD}	VCC	Deep standby Stop mode (When RAM is off)	-	96	TBD	μA	*3, *4 Ta = +25°C
					-	TBD	μA	*3, *4 Ta = +85°C
					-	TBD	μA	*3, *4 Ta = +105°C
			106		TBD	μA	*3, *4 Ta = +25°C	
			-		TBD	μA	*3, *4 Ta = +85°C	
			-		TBD	μA	*3, *4 Ta = +105°C	
	I _{CCRD}		Deep standby RTC mode * ⁶ (When RAM is off)	32 kHz	96	TBD	μA	*3, *4 Ta = +25°C
					-	TBD	μA	*3, *4 Ta = +85°C
					-	TBD	μA	*3, *4 Ta = +105°C
					106	TBD	μA	*3, *4 Ta = +25°C
					-	TBD	μA	*3, *4 Ta = +85°C
					-	TBD	μA	*3, *4 Ta = +105°C
	I _{CCVBAT}	VBAT	RTC stop	-	7	TBD	nA	*3, *4, *5 Ta = +25°C
					-	TBD	μA	*3, *4, *5 Ta = +85°C
					-	TBD	μA	*3, *4, *5 Ta = +105°C
			1.0		TBD	μA	*3, *4 Ta = +25°C	
			-		TBD	μA	*3, *4 Ta = +85°C	
			-		TBD	μA	*3, *4 Ta = +105°C	

1 : V_{CC} = 3.3V

2 : V_{CC} = 5.5V

3 : When all ports are fixed

4 : When LVD is off

5 : When sub oscillation is off

6 : When using the crystal oscillator of 32 MHz (including the current consumption of the oscillation circuit)

Table 14-10 Typical and maximum current consumption in Low-voltage detection circuit, Main flash memory write/erase

Parameter	Symbol	Pin Name	Conditions	Value			Unit	Remarks
				Min	Typ	Max		
Low-voltage detection circuit (LVD) power supply current	I _{CC} LVD	VCC	At operation	-	4	7	μA	For occurrence of interrupt
MainFlash memory write/erase current	I _{CC} FLASH		At write/erase	-	13.4	15.9	mA	

Peripheral Current Dissipation

Clock system	Peripheral	Unit	Frequency (MHz)			Unit	Remarks
			50	100	200		
HCLK	GPIO	All ports	0.39	0.81	1.56	mA	
	DMAC	-	0.99	1.97	3.82		
	DSTC	-	0.73	1.49	2.86		
	External bus I/F	-	0.25	0.48	0.97		
	SD card I/F	-	0.74	1.47	2.90		
	USB	1 ch	0.48	0.95	1.89		
	Ethernet-MAC	-	1.85	3.63	7.20		
	I ² S	-	0.51	1.02	1.99		
	High-Speed Quad SPI	-	0.48	0.97	1.49		
	Programmable CRC	-	0.05	0.10	0.22		
PCLK1	Base timer	4 ch	0.21	0.42	0.83	mA	
	Multi-functional timer/PPG	1 unit/4 ch	0.83	1.65	3.25		
	Quadrature position/revolution counter	1 unit	0.07	0.13	0.27		
	A/D converter	1 unit	0.31	0.60	1.17		
PCLK2	Multi-function serial	1 ch	0.41	0.81	-	mA	
	HDMI-CEC/ Remote control receiver	1 ch	0.20	0.39	-		

14.3.2 Pin Characteristics

($V_{CC} = USBV_{CC0} = USBV_{CC1} = ETHV_{CC} = AV_{CC} = 2.7V$ to $5.5V$, $V_{SS} = AV_{SS} = 0V$)

Parameter	Symbol	Pin Name	Conditions	Value			Unit	Remarks
				Min	Typ	Max		
"H" level input voltage (hysteresis input)	V_{IHS}	CMOS hysteresis input pin, MD0, MD1	-	$V_{CC} \times 0.8$	-	$V_{CC} + 0.3$	V	
			-	$ETHV_{CC} \times 0.8$	-	$ETHV_{CC} + 0.3$	V	
		5V tolerant input pin	-	$V_{CC} \times 0.8$	-	$V_{SS} + 5.5$	V	
		Input pin doubled as I ² C Fm+	-	$V_{CC} \times 0.7$	-	$V_{SS} + 5.5$	V	
		TTL Schmitt input pin	-	2.0	-	$ETHV_{CC} + 0.3$	V	
"L" level input voltage (hysteresis input)	V_{ILS}	CMOS hysteresis input pin, MD0, MD1	-	$V_{SS} - 0.3$	-	$V_{CC} \times 0.2$	V	
			-	$V_{SS} - 0.3$	-	$ETHV_{CC} \times 0.2$	V	
		5V tolerant input pin	-	$V_{SS} - 0.3$	-	$V_{CC} \times 0.2$	V	
		Input pin doubled as I ² C Fm+	-	V_{SS}	-	$V_{CC} \times 0.3$	V	
		TTL Schmitt input pin	-	$V_{SS} - 0.3$	-	0.8	V	
"H" level output voltage	V_{OH}	4 mA type	$V_{CC} \geq 4.5V$, $I_{OH} = -4$ mA	$V_{CC} - 0.5$	-	V_{CC}	V	
			$V_{CC} < 4.5V$, $I_{OH} = -2$ mA					
			$ETHV_{CC} \geq 4.5V$, $I_{OH} = -4$ mA	$V_{CC} - 0.5$	-	$ETHV_{CC}$	V	
			$ETHV_{CC} < 4.5V$, $I_{OH} = -2$ mA					
		8 mA type	$V_{CC} \geq 4.5V$, $I_{OH} = -8$ mA	$V_{CC} - 0.5$	-	V_{CC}	V	
			$V_{CC} < 4.5V$, $I_{OH} = -4$ mA					
			$ETHV_{CC} \geq 4.5V$, $I_{OH} = -8$ mA	$ETHV_{CC} - 0.5$	-	$ETHV_{CC}$	V	
			$ETHV_{CC} < 4.5V$, $I_{OH} = -4$ mA					
		12 mA type	$V_{CC} \geq 4.5V$, $I_{OH} = -12$ mA	$V_{CC} - 0.5$	-	V_{CC}	V	
			$V_{CC} < 4.5V$, $I_{OH} = -8$ mA					
		The pin doubled as USB I/O	$USBV_{CC} \geq 4.5V$, $I_{OH} = -20.5$ mA	$USBV_{CC} - 0.4$	-	$USBV_{CC}$	V	*1
			$USBV_{CC} < 4.5V$, $I_{OH} = -13.0$ mA					
		The pin doubled as I ² C Fm+	$V_{CC} \geq 4.5V$, $I_{OH} = -4$ mA	$V_{CC} - 0.5$	-	V_{CC}	V	At GPIO
			$V_{CC} < 4.5V$, $I_{OH} = -3$ mA					

Parameter	Symbol	Pin Name	Conditions	Value			Unit	Remarks		
				Min	Typ	Max				
"L" level output voltage	V_{OL}	4 mA type	$V_{CC} \geq 4.5V,$ $I_{OL} = 4 \text{ mA}$	V_{SS}	-	0.4	V			
			$V_{CC} < 4.5V,$ $I_{OL} = 2 \text{ mA}$							
			$ETHV_{CC} \geq 4.5V,$ $I_{OL} = 4 \text{ mA}$	V_{SS}	-	0.4			V	
			$RTHV_{CC} < 4.5V,$ $I_{OL} = 2 \text{ mA}$							
		8 mA type	$V_{CC} \geq 4.5V,$ $I_{OL} = 8 \text{ mA}$	V_{SS}	-	0.4	V			
			$V_{CC} < 4.5V,$ $I_{OL} = 4 \text{ mA}$							
			$ETHV_{CC} \geq 4.5V,$ $I_{OL} = 8 \text{ mA}$	V_{SS}	-	0.4			V	
			$RTHV_{CC} < 4.5V,$ $I_{OL} = 4 \text{ mA}$							
		12 mA type	$V_{CC} \geq 4.5V,$ $I_{OL} = 12 \text{ mA}$	V_{SS}	-	0.4	V			
			$V_{CC} < 4.5V,$ $I_{OL} = 8 \text{ mA}$							
		The pin doubled as USB I/O	$USBV_{CC} \geq 4.5V,$ $I_{OL} = 18.5 \text{ mA}$	V_{SS}	-	0.4			V	*1
			$USBV_{CC} < 4.5V,$ $I_{OL} = 10.5 \text{ mA}$							
The pin doubled as I ² C Fm+	$V_{CC} \geq 4.5V,$ $I_{OL} = 4 \text{ mA}$	V_{SS}	-	0.4	V	At GPIO				
	$V_{CC} < 4.5V,$ $I_{OL} = 3 \text{ mA}$									
	$V_{CC} \leq 4.5V,$ $I_{OL} = 20 \text{ mA}$					At I ² C Fm+				
Input leak current	I_{IL}	-	-	- 5	-	+ 5	μA			
Pull-up resistor value	R_{PU}	Pull-up pin	$V_{CC} \geq 4.5V$	25	50	100	$k\Omega$			
			$V_{CC} < 4.5V$	30	80	200				
Input capacitance	C_{IN}	Other than VCC, USBVCC0, USBVCC1, ETHVCC, VBAT, VSS, AVCC, AVSS, AVRH	-	-	5	15	pF			

1 : $USBV_{cc0}$ and $USBV_{cc1}$ are described as $USBV_{cc}$.

14.4 AC Characteristics

14.4.1 Main Clock Input Characteristics

($V_{CC} = AV_{CC} = 2.7V$ to $5.5V$, $V_{SS} = AV_{SS} = 0V$, $T_a = -40^{\circ}C$ to $+105^{\circ}C$)

Parameter	Symbol	Pin Name	Conditions	Value		Unit	Remarks	
				Min	Max			
Input frequency	F_{CH}	X0, X1	$V_{CC} \geq 4.5V$	4	48	MHz	When crystal oscillator is connected	
			$V_{CC} < 4.5V$	4	20			
			$V_{CC} \geq 4.5V$	4	48	MHz		
			$V_{CC} < 4.5V$	4	20			
Input clock cycle	t_{CYLH}		$V_{CC} \geq 4.5V$	20.83	250	ns	When using external clock	
			$V_{CC} < 4.5V$	50	250			
Input clock pulse width	-			P_{WH}/t_{CYLH} , P_{WL}/t_{CYLH}	45	55	%	When using external clock
Input clock rise time and fall time	t_{CF} , t_{CR}			-	-	5	ns	When using external clock
Internal operating clock ^{*1} frequency	F_{CC}	-	-	-	200	MHz	Base clock (HCLK/FCLK)	
	F_{CP0}	-	-	-	100	MHz	APB0bus clock ^{*2}	
	F_{CP1}	-	-	-	200	MHz	APB1bus clock ^{*2}	
	F_{CP2}	-	-	-	100	MHz	APB2bus clock ^{*2}	
Internal operating clock ^{*1} cycle time	t_{CYCC}	-	-	5	-	ns	Base clock (HCLK/FCLK)	
	t_{CYCP0}	-	-	10	-	ns	APB0bus clock ^{*2}	
	t_{CYCP1}	-	-	5	-	ns	APB1bus clock ^{*2}	
	t_{CYCP2}	-	-	10	-	ns	APB2bus clock ^{*2}	

1 : For more information about each internal operating clock, see "CHAPTER 2-1: Clock" in "FM4 Family Peripheral Manual Main Part (MN709-00001)."

2 : For more about each APB bus to which each peripheral is connected, see "10. Block Diagram" in this data sheet.

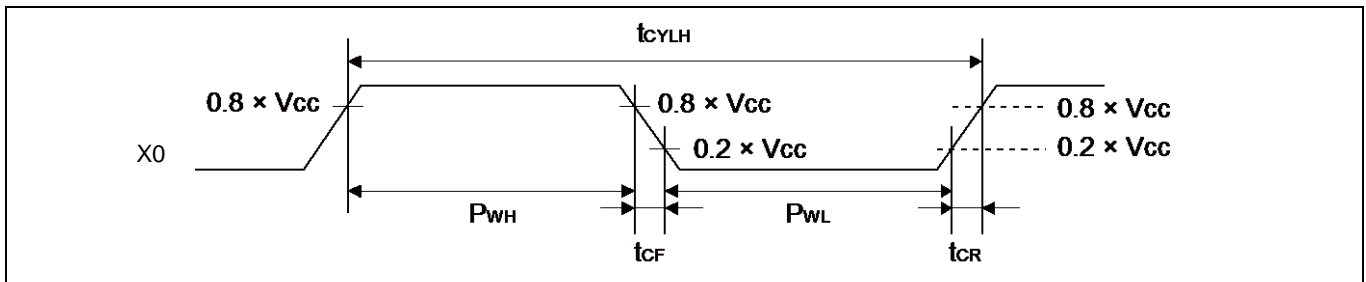

14.4.2 Sub Clock Input Characteristics

(V_{BAT} = 1.65V to 5.5V, V_{SS} = 0V)

Parameter	Symbol	Pin Name	Conditions	Value			Unit	Remarks
				Min	Typ	Max		
Input frequency	1/t _{CYLL}	X0A, X1A	-	-	32.768	-	kHz	When crystal oscillator is connected *
			-	32	-	100	kHz	When using external clock
Input clock cycle	t _{CYLL}		-	10	-	31.25	μs	When using external clock
Input clock pulse width	-		P _{WH} /t _{CYLL} , P _{WL} /t _{CYLL}	45	-	55	%	When using external clock

* : For more information about crystal oscillator, see "Sub crystal oscillator" in "9. Handling Devices."

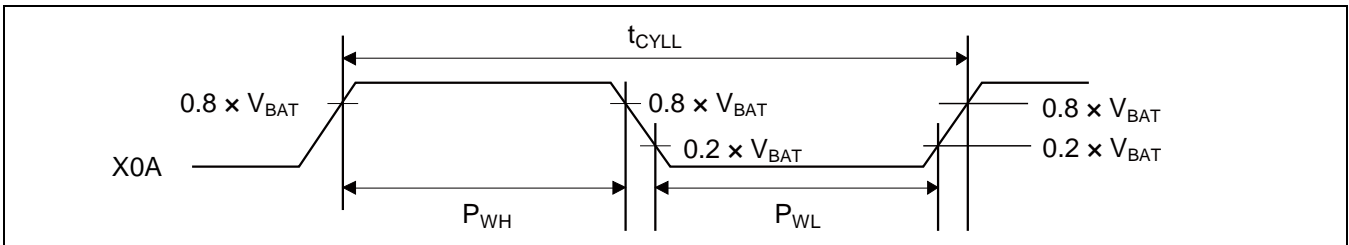

14.4.3 Built-In CR Oscillation Characteristics

Built-In High-Speed CR

(V_{CC} = 2.7V to 5.5V, V_{SS} = 0V)

Parameter	Symbol	Conditions	Value			Unit	Remarks
			Min	Typ	Max		
Clock frequency	F _{CRH}	T _j = - 20°C to + 105°C	3.92	4	4.08	MHz	When trimming *1
		T _j = - 40°C to + 125°C	3.88	4	4.12		
		T _j = - 40°C to + 125°C	3	4	5		When not trimming
Frequency stabilization time	t _{CRWT}	-	-	-	30	μs	*2

1 : In the case of using the values in CR trimming area of flash memory at shipment for frequency/temperature trimming

2 : This is the time to stabilize the frequency of the high-speed CR clock after setting trimming value. During this period, it is able to use the high-speed CR clock as a source clock.

Built-In Low-speed CR

(V_{CC} = 2.7V to 5.5V, V_{SS} = 0V)

Parameter	Symbol	Condition	Value			Unit	Remarks
			Min	Typ	Max		
Clock frequency	F _{CRL}	-	50	100	150	kHz	

14.4.4 Operating Conditions of Main PLL (in the case of using main clock for input clock of PLL)

 (V_{CC} = 2.7V to 5.5V, V_{SS} = 0V)

Parameter	Symbol	Value			Unit	Remarks
		Min	Typ	Max		
PLL oscillation stabilization wait time* ¹ (lock up time)	t _{LOCK}	100	-	-	μs	
PLL input clock frequency	F _{PLLI}	4	-	16	MHz	
PLL multiplication rate	-	13	-	100	multiplier	
PLL macro oscillation clock frequency	F _{PLLO}	200	-	400	MHz	
Main PLL clock frequency* ²	F _{CLKPLL}	-	-	200	MHz	

1 : Time from when the PLL starts operating until the oscillation stabilizes

2 : For more information about Main PLL clock (CLKPLL), see "Chapter 2-1: Clock" in "FM4 Family Peripheral Manual Main Part (MN709-00001)."

14.4.5 Operating Conditions of USB/Ethernet PLL · I²S PLL (in the case of using main clock for input clock of PLL)

 (V_{CC} = 2.7V to 5.5V, V_{SS} = 0V)

Parameter	Symbol	Value			Unit	Remarks
		Min	Typ	Max		
PLL oscillation stabilization wait time * ¹ (lock up time)	t _{LOCK}	100	-	-	μs	
PLL input clock frequency	F _{PLLI}	4	-	16	MHz	
PLL multiplication rate	-	13	-	100	multiplier	
PLL macro oscillation clock frequency	F _{PLLO}	200	-	400	MHz	USB/Ethernet
				307.2	MHz	I ² S
USB/Ethernet clock frequency * ²	F _{CLKPLL}	-	-	50	MHz	After the M frequency division
I ² S clock frequency * ³	F _{CLKPLL}	-	-	12.288	MHz	After the M frequency division

1 : Time from when the PLL starts operating until the oscillation stabilizes

2 : For more information about USB/Ethernet clock, see "Chapter 2-2: USB/Ethernet Clock Generation" in "FM4 Family Peripheral Manual Communication Macro Part (MN709-00004)."

3 : For more information about I²S clock, see "Chapter 7-1: I²S Clock Generation" in "FM4 Family Peripheral Manual Communication Macro Part (MN709-00004)."

14.4.6 Operating Conditions of Main PLL (in the case of using built-in high-speed CR clock for input clock of main PLL)

(V_{CC} = 2.7V to 5.5V, V_{SS} = 0V)

Parameter	Symbol	Value			Unit	Remarks
		Min	Typ	Max		
PLL oscillation stabilization wait time ^{*1} (lock up time)	t _{LOCK}	100	-	-	μs	
PLL input clock frequency	F _{PLLI}	3.8	4	4.2	MHz	
PLL multiplication rate	-	50	-	95	multiplier	
PLL macro oscillation clock frequency	F _{PLLO}	190	-	400	MHz	
Main PLL clock frequency ^{*2}	F _{CLKPLL}	-	-	200	MHz	

1 : Time from when the PLL starts operating until the oscillation stabilizes

2 : For more information about main PLL clock (CLKPLL), see "Chapter 2-1: Clock" in "FM4 Family Peripheral Manual Main Part (MN709-00001)."

Note:

- The high-speed CR clock (CLKHC) should be set with frequency/temperature trimming to act as the source clock of the main PLL.

14.4.7 Reset Input Characteristics

(V_{CC} = 2.7V to 5.5V, V_{SS} = 0V)

Parameter	Symbol	Pin Name	Conditions	Value		Unit	Remarks
				Min	Typ		
Reset input time	t _{INITX}	INITX	-	500	-	ns	

14.4.8 Power-On Reset Timing

(V_{CC} = 2.7V to 5.5V, V_{SS} = 0V)

Parameter	Symbol	Pin Name	Value		Unit	Remarks
			Min	Typ		
Power supply rise time	Tr	VCC	0	-	ms	
Power supply shut down time	Toff		1	-	ms	
Time until releasing Power-on reset	Tprt		0.33	0.60	ms	

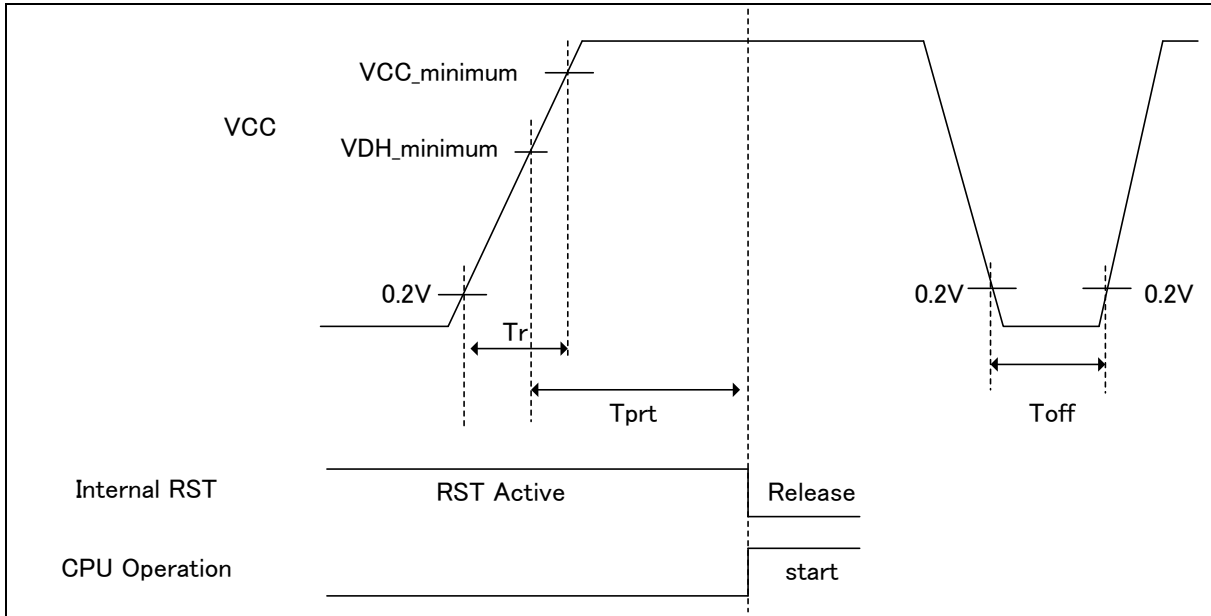

Glossary

- V_{CC_minimum}: minimum V_{CC} of recommended operating conditions
- V_{DH_minimum}: minimum release voltage of low-voltage detection reset
See "14.8. Low-Voltage Detection Characteristics."

14.4.9 GPIO Output Characteristics

(V_{CC} = 2.7V to 5.5V, V_{SS} = 0V)

Parameter	Symbol	Pin Name	Conditions	Value		Unit	Remarks
				Min	Typ		
Output frequency	t _{PCYCLE}	Pxx*	V _{CC} ≥ 4.5V	-	50	MHz	
			V _{CC} < 4.5V	-	32	MHz	

* : GPIO is a target.

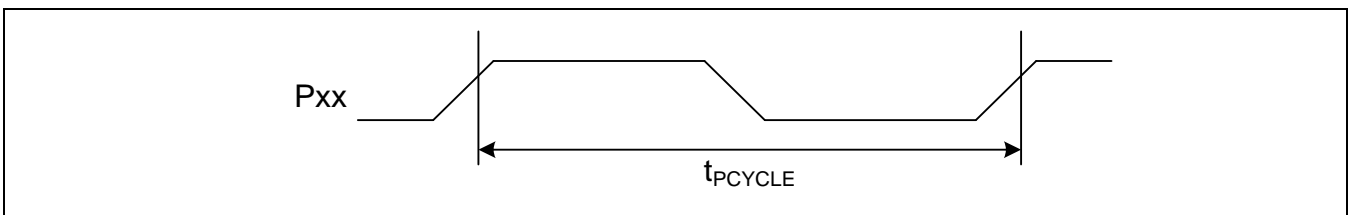

14.4.10 External Bus Timing

External Bus Clock Output Characteristics

Parameter	Symbol	Pin Name	Conditions	Value		Unit	Remarks
				Min	Typ		
Output frequency	t_{CYCLE}	MCLKOUT *1		-	50 *2	MHz	

1 : The external bus clock (MCLKOUT) is a divided clock of HCLK.

For more information about setting of clock divider, see "Chapter 14: External Bus Interface" in "FM4 Family Peripheral Manual Main Part (MN709-00001)."

2 : Generate MCLKOUT at setting more than four divisions when the AHB bus clock exceeds 100 MHz.

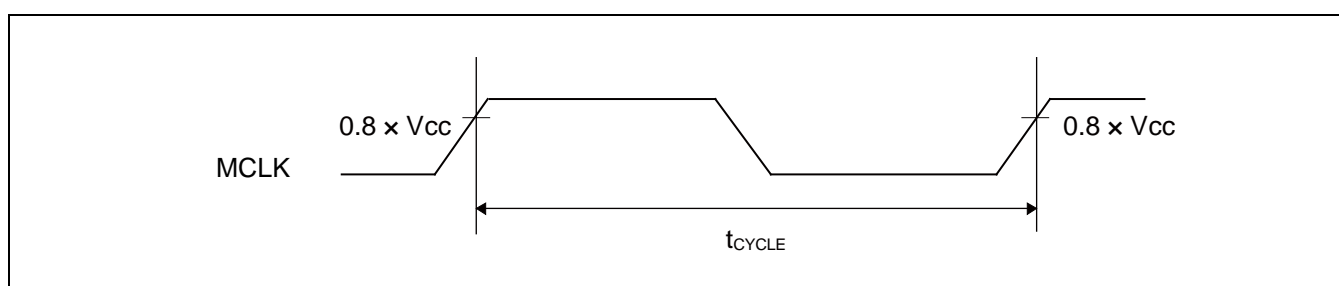

External bus signal I/O characteristics

($V_{CC} = 2.7V$ to $5.5V$, $V_{SS} = 0V$)

Parameter	Symbol	Conditions	Value	Unit	Remarks
Signal input characteristics	V_{IH}	-	$0.8 \times V_{CC}$	V	
	V_{IL}		$0.2 \times V_{CC}$	V	
Signal output characteristics	V_{OH}		$0.8 \times V_{CC}$	V	
	V_{OL}		$0.2 \times V_{CC}$	V	

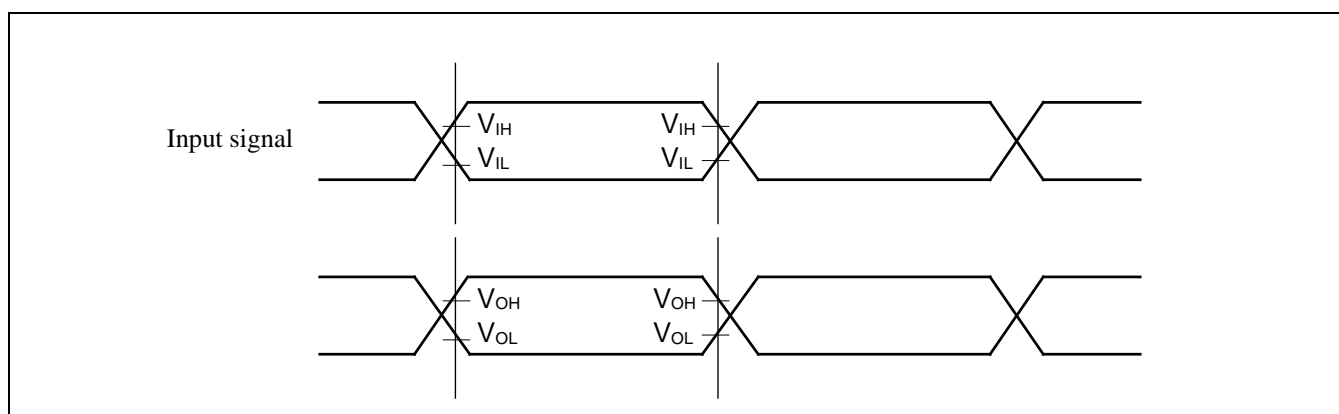

Separate Bus Access Asynchronous SRAM Mode

 (V_{CC} = 2.7V to 5.5V, V_{SS} = 0V)

Parameter	Symbol	Pin Name	Conditions	Value		Unit	Remarks
				Min	Max		
MOEX Minimum pulse width	t _{OE}	MOEX	-	MCLKxn-3	-	ns	
MCSX ↓ → Address output delay time	t _{CSL-AV}	MCSX[7: 0], MAD[24: 0]	-	-9	+9	ns	
MOEX ↑ → Address hold time	t _{OEH-AX}	MOEX, MAD[24: 0]	-	0	MCLKxm+9	ns	
MCSX ↓ → MOEX ↓ delay time	t _{CSL-OEL}	MOEX, MCSX[7: 0]	-	MCLKxm-9	MCLKxm+9	ns	
MOEX ↑ → MCSX ↑ time	t _{OEH-CSH}		-	0	MCLKxm+9	ns	
MCSX ↓ → MDQM ↓ delay time	t _{CSL-RDQML}	MCSX, MDQM[3: 0]	-	MCLKxm-9	MCLKxm+9	ns	
Data set up → MOEX ↑ time	t _{DS-OE}	MOEX, MADATA[31: 0]	-	20	-	ns	
MOEX ↑ → Data hold time	t _{DH-OE}	MOEX, MADATA[31: 0]	-	0	-	ns	
MWEX Minimum pulse width	t _{WE}	MWEX	-	MCLKxn-3	-	ns	
MWEX ↑ → Address output delay time	t _{WEH-AX}	MWEX, MAD[24: 0]	-	0	MCLKxm+9	ns	
MCSX ↓ → MWEX ↓ delay time	t _{CSL-WEL}	MWEX, MCSX[7: 0]	-	MCLKxn-9	MCLKxn+9	ns	
MWEX ↑ → MCSX ↑ delay time	t _{WEH-CSH}		-	0	MCLKxm+9	ns	
MCSX ↓ → MDQM ↓ delay time	t _{CSL-WDQML}	MCSX, MDQM[3: 0]	-	MCLKxn-9	MCLKxn+9	ns	
MCSX ↓ → Data output time	t _{CSL-DX}	MCSX, MADATA[31: 0]	-	MCLK-9	MCLK+9	ns	
MWEX ↑ → Data hold time	t _{WEH-DX}	MWEX, MADATA[31: 0]	-	0	MCLKxm+9	ns	

Note:

- When the external load capacitance C_L = 30 pF (m = 0 to 15, n = 1 to 16)

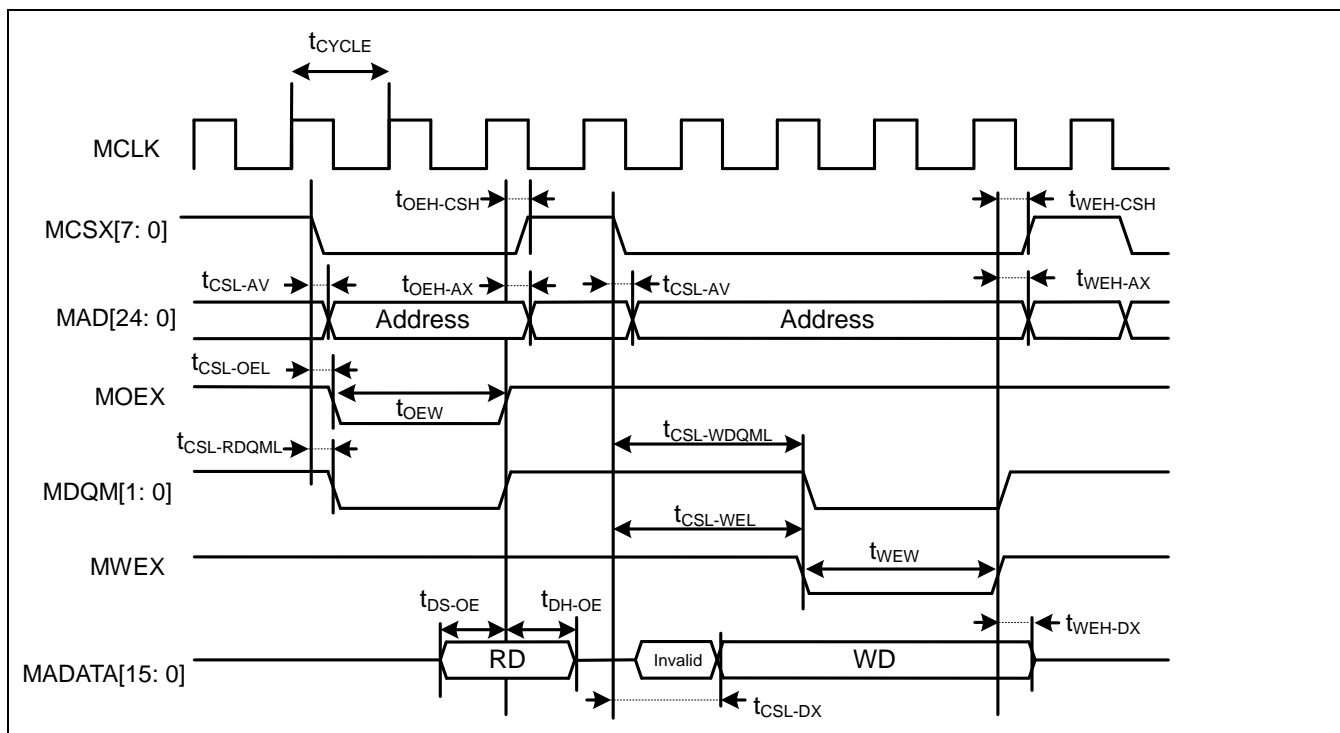

Separate Bus Access Synchronous SRAM Mode

(V_{CC} = 2.7V to 5.5V, V_{SS} = 0V)

Parameter	Symbol	Pin Name	Conditions	Value		Unit	Remarks
				Min	Max		
Address delay time	t _{AV}	MCLK, MAD[24: 0]	-	1	9	ns	
MCSX delay time	t _{CSL}	MCLK, MCSX[7: 0]	-	1	9	ns	
	t _{CSH}		-	1	9	ns	
MOEX delay time	t _{REL}	MCLK, MOEX	-	1	9	ns	
	t _{REH}		-	1	9	ns	
Data set up →MCLK ↑ time	t _{DS}	MCLK, MADATA[31: 0]	-	19	-	ns	
MCLK ↑ → Data hold time	t _{DH}	MCLK, MADATA[31: 0]	-	0	-	ns	
MWEX delay time	t _{WEL}	MCLK, MWEX	-	1	9	ns	
	t _{WEH}		-	1	9	ns	
MDQM[1: 0] delay time	t _{DQML}	MCLK, MDQM[3: 0]	-	1	9	ns	
	t _{DQMH}		-	1	9	ns	
MCLK ↑ → Data output time	t _{ODS}	MCLK, MADATA[31: 0]	-	MCLK+1	MCLK+18	ns	
MCLK ↑ → Data hold time	t _{OD}	MCLK, MADATA[31: 0]	-	1	18	ns	

Note:

- When the external load capacitance C_L = 30 pF

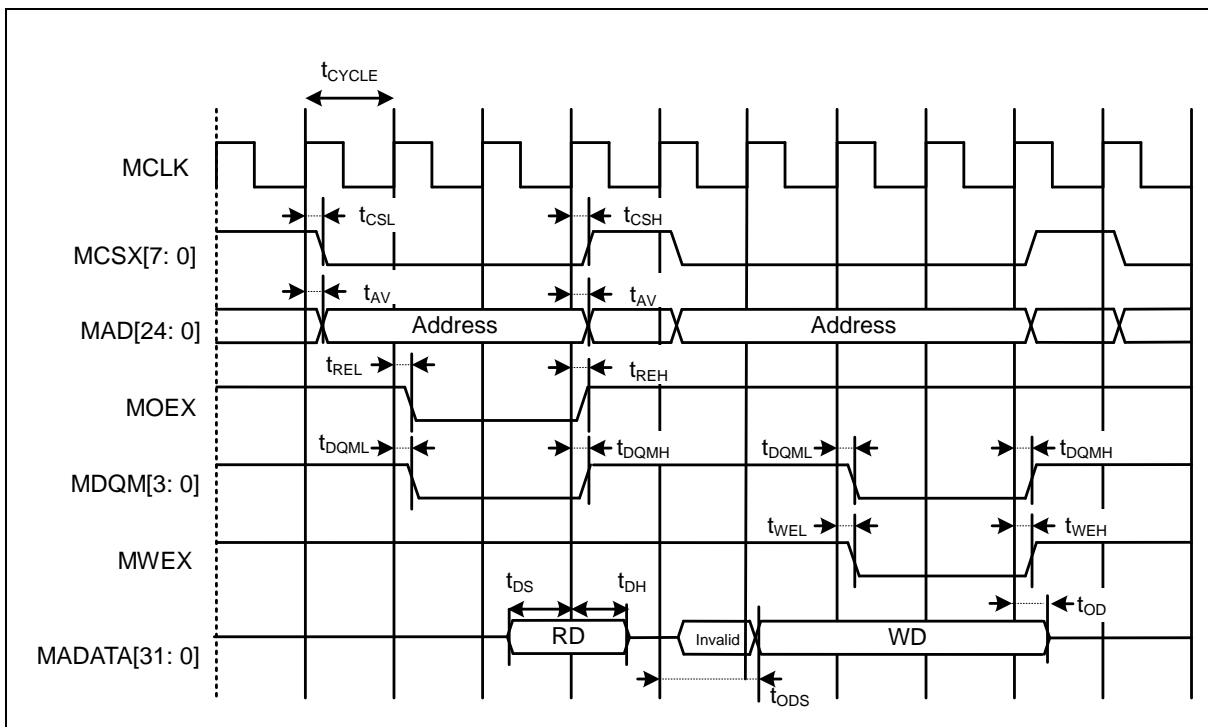

Multiplexed Bus Access Asynchronous SRAM Mode

($V_{CC} = 2.7V$ to $5.5V$, $V_{SS} = 0V$)

Parameter	Symbol	Pin Name	Conditions	Value		Unit	Remarks
				Min	Max		
Multiplexed address delay time	$t_{ALE-CHMADV}$	MALE, MAD[24: 0]	-	0	10	ns	
Multiplexed address hold time	t_{CHMADH}		-	$MCLK \times n + 0$	$MCLK \times n + 10$	ns	

Note:

- When the external load capacitance $C_L = 30$ pF ($m = 0$ to 15 , $n = 1$ to 16)

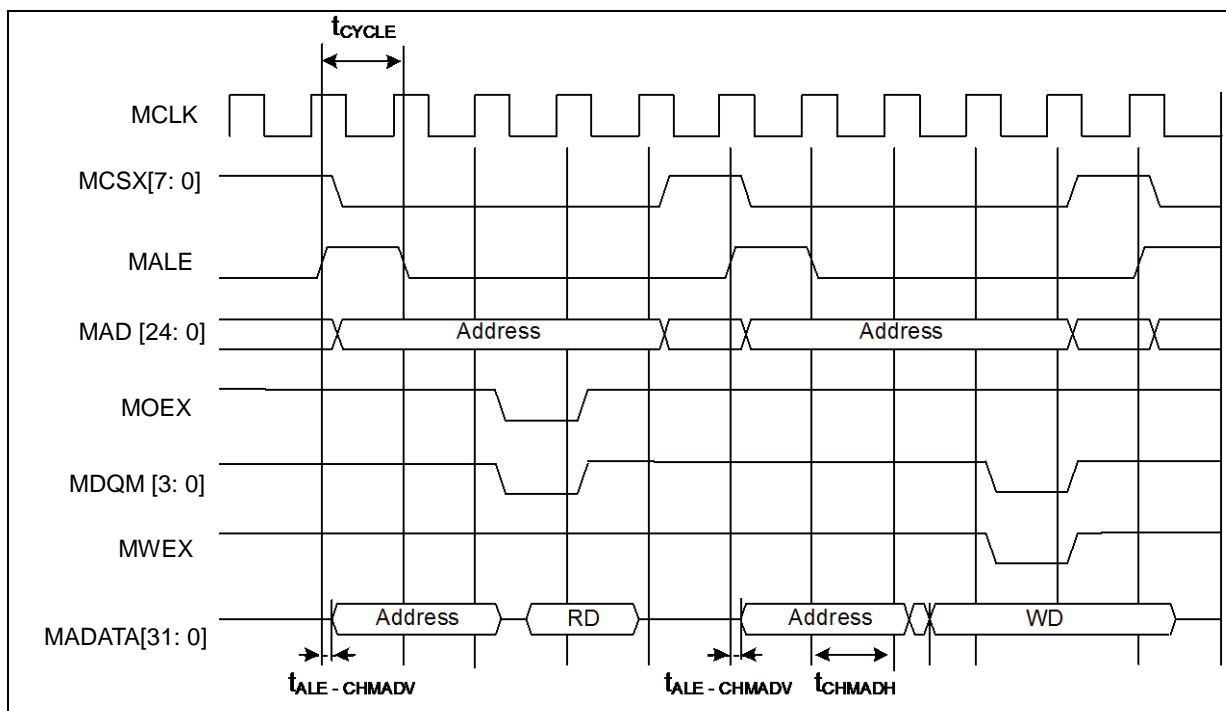

Multiplexed Bus Access Synchronous SRAM Mode

(V_{CC} = 2.7V to 5.5V, V_{SS} = 0V)

Parameter	Symbol	Pin Name	Conditions	Value		Unit	Remarks
				Min	Max		
MALE delay time	t _{CHAL}	MCLK, MALE	-	1	9		
	t _{CHAH}		-	1	9		
MCLK ↑ → Multiplexed address delay time	t _{CHMADV}	MCLK, MADATA[31: 0]	-	1	t _{OD}	ns	
MCLK ↑ → Multiplexed data output time	t _{CHMADX}		-	1	t _{OD}	ns	

Note:

- When the external load capacitance C_L = 30 pF

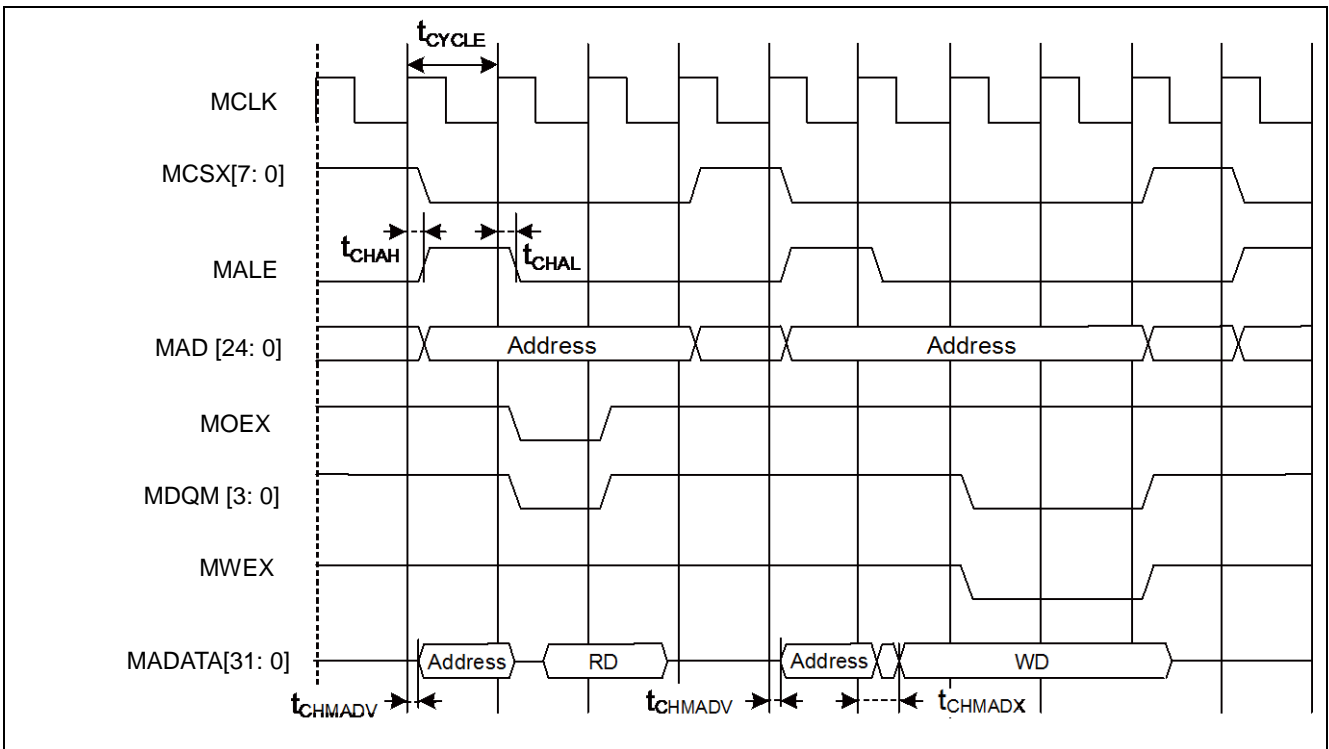

NAND flash Mode

($V_{CC} = 2.7V$ to $5.5V$, $V_{SS} = 0V$)

Parameter	Symbol	Pin Name	Conditions	Value		Unit	Remarks
				Min	Max		
MNREX Min pulse width	t_{NREW}	MNREX	-	$MCLK \times n - 3$	-	ns	
Data set up → MNREX ↑ time	t_{DS-NRE}	MNREX, MADATA[31: 0]	-	20	-	ns	
MNREX ↑ → Data hold time	t_{DH-NRE}	MNREX, MADATA[31: 0]	-	0	-	ns	
MNALE ↑ → MNWEX delay time	$t_{ALEH-NWEL}$	MNALE, MNWEX	-	$MCLK \times m - 9$	$MCLK \times m + 9$	ns	
MNALE ↓ → MNWEX delay time	$t_{ALEL-NWEL}$	MNALE, MNWEX	-	$MCLK \times m - 9$	$MCLK \times m + 9$	ns	
MNCLE ↑ → MNWEX delay time	$t_{CLEH-NWEL}$	MNCLE, MNWEX	-	$MCLK \times m - 9$	$MCLK \times m + 9$	ns	
MNWEX ↑ → MNCLE delay time	$t_{NWEH-CLEL}$	MNCLE, MNWEX	-	0	$MCLK \times m + 9$	ns	
MNWEX Min pulse width	t_{NWEW}	MNWEX	-	$MCLK \times n - 3$	-	ns	
MNWEX ↓ → Data output time	$t_{NWEV-DV}$	MNWEX, MADATA[31: 0]	-	-9	9	ns	
MNWEX ↑ → Data hold time	$t_{NWEH-DX}$	MNWEX, MADATA[31: 0]	-	0	$MCLK \times m + 9$	ns	

Note:

- When the external load capacitance $C_L = 30$ pF ($m = 0$ to 15 , $n = 1$ to 16)

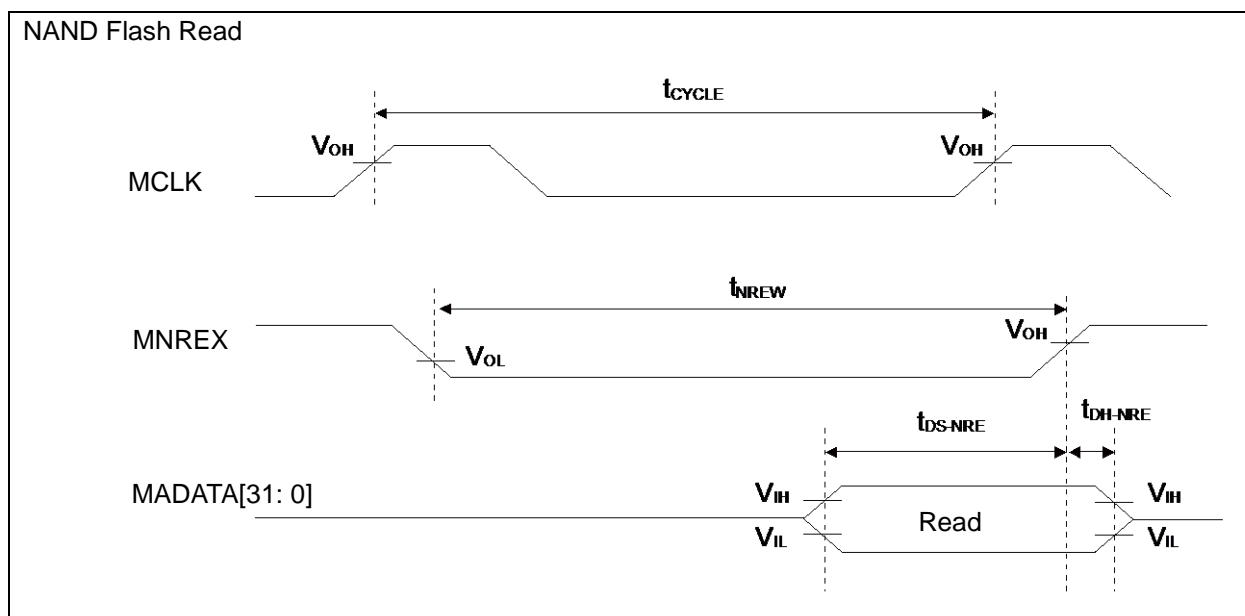

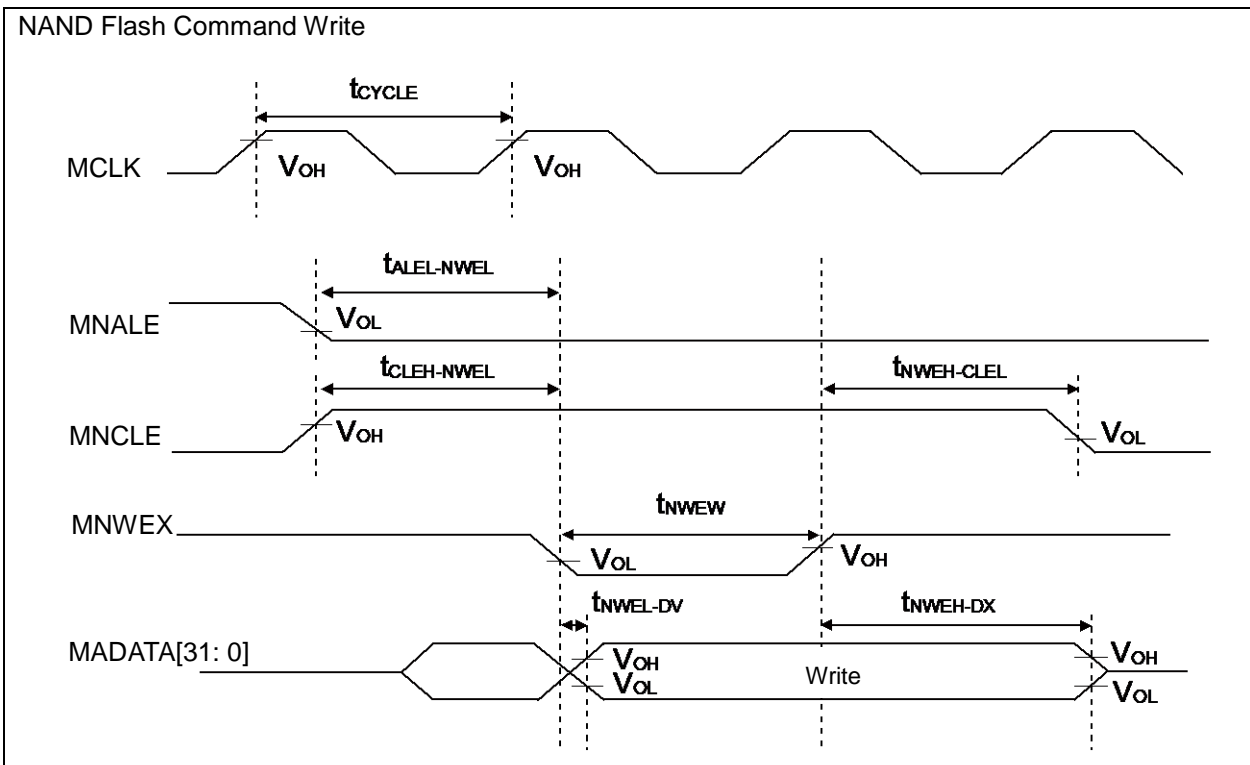
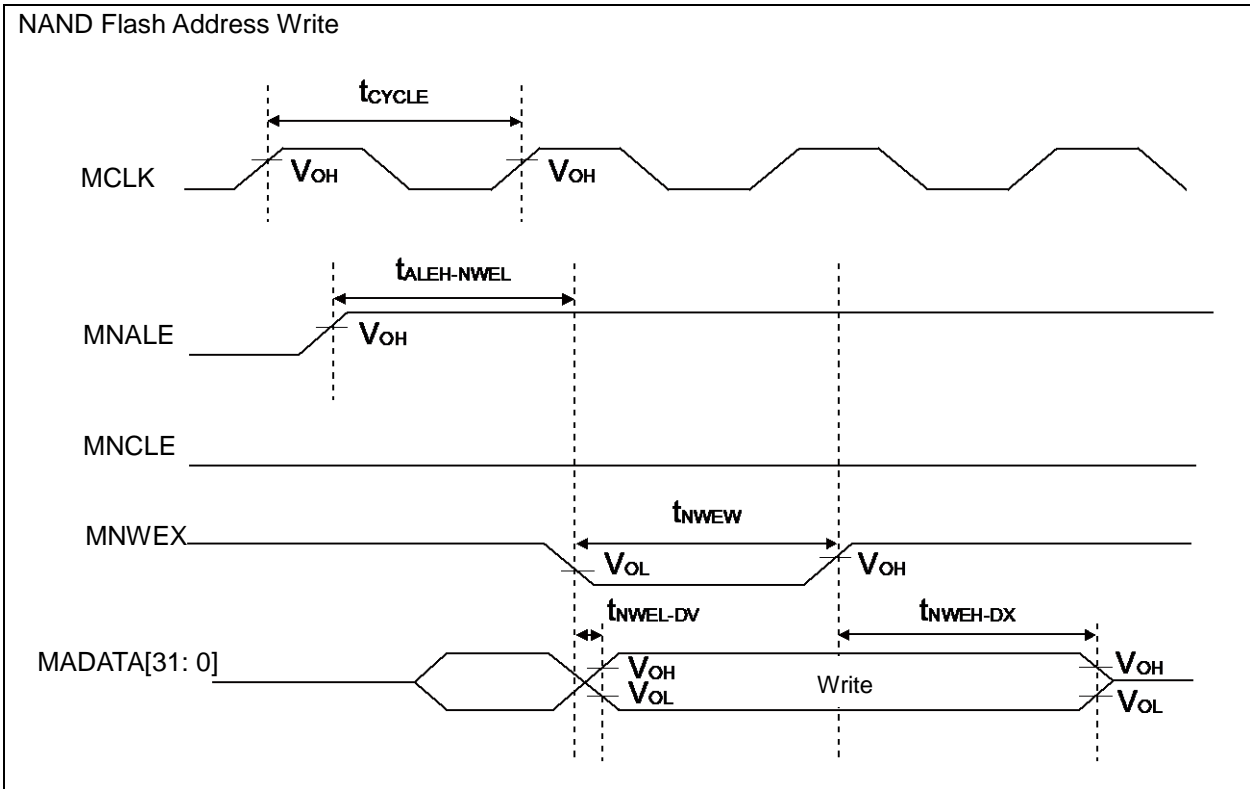

External Ready Input Timing

($V_{CC} = 2.7V$ to $5.5V$, $V_{SS} = 0V$)

Parameter	Symbol	Pin Name	Conditions	Value		Unit	Remarks
				Min	Max		
MCLK↑ MRDY input setup time	t_{RDYI}	MCLK, MRDY	-	19	-	ns	

■ When RDY is input

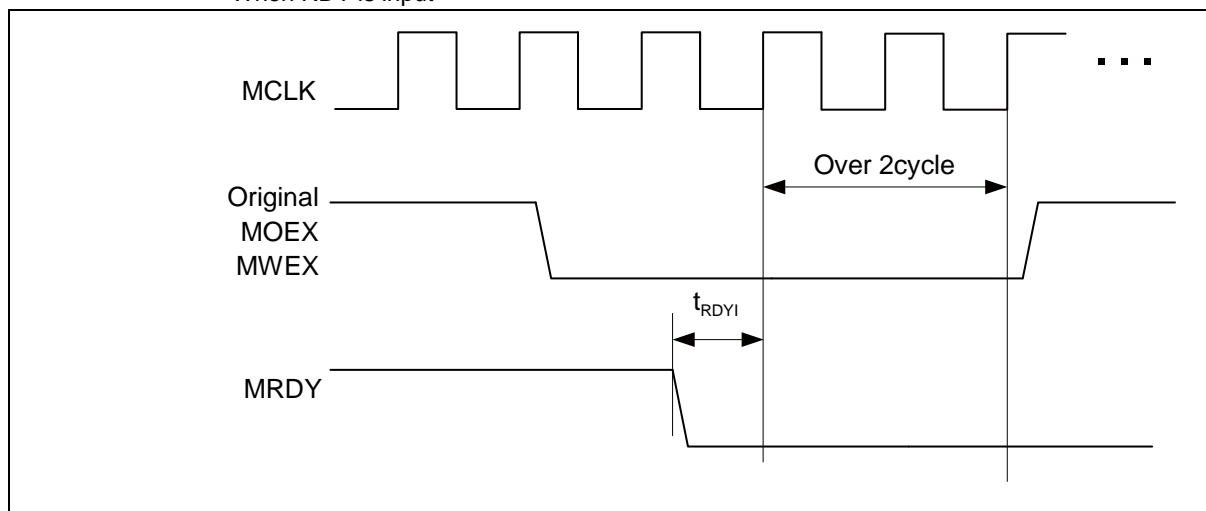

■ When RDY is released

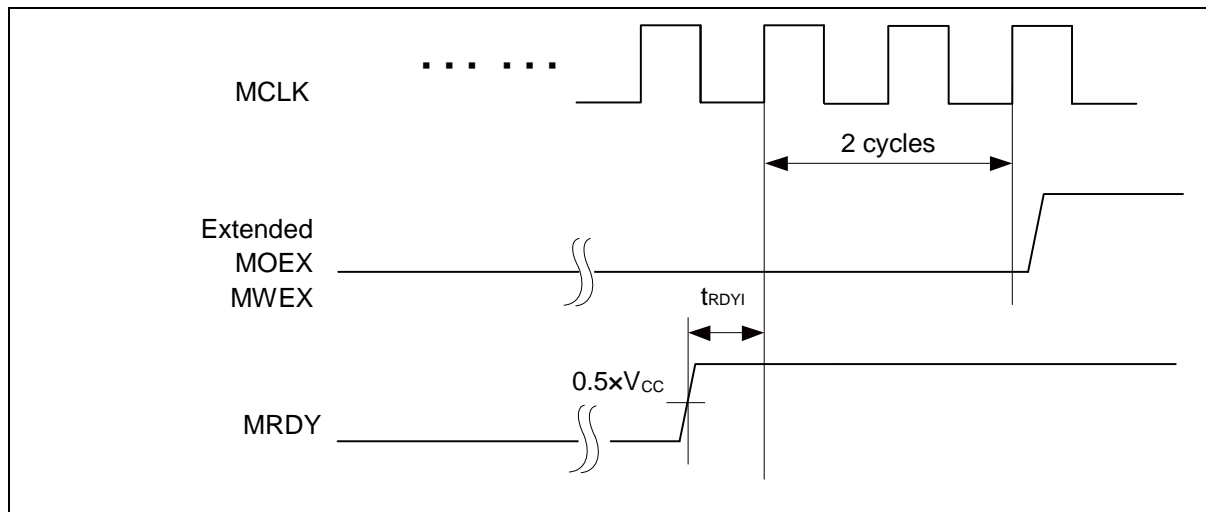

SDRAM Mode

 (V_{CC} = 2.7V to 3.6V, V_{SS} = 0V)

Parameter	Symbol	Pin Name	Value	Unit		Unit	Remarks
				Min	Max		
Output frequency	t _{CYCSD}	MSDCLK	-	-	50	MHz	
Address delay time	t _{AOSD}	MSDCLK, MAD[15: 0]	-	2	12	ns	
MSDCLK ↑ → Data output delay time	t _{DOSD}	MSDCLK, MADATA[31: 0]	-	2	12	ns	
MSDCLK ↑ → Data output Hi-Z time	t _{DOZSD}	MSDCLK, MADATA[31: 0]	-	2	19.5	ns	
MDQM[3: 0] delay time	t _{WROSD}	MSDCLK, MDQM[1: 0]	-	1	12	ns	
MCSX delay time	t _{MCSSD}	MSDCLK, MCSX8	-	2	12	ns	
MRASX delay time	t _{RASSD}	MSDCLK, MRASX	-	2	12	ns	
MCASX delay time	t _{CASSD}	MSDCLK, MCASX	-	2	12	ns	
MSDWEX delay time	t _{MWESD}	MSDCLK, MSDWEX	-	2	12	ns	
MSDCKE delay time	t _{CKESD}	MSDCLK, MSDCKE	-	2	12	ns	
Data set up time	t _{DSSD}	MSDCLK, MADATA[31: 0]	-	19	-	ns	
Data hold time	t _{DHSD}	MSDCLK, MADATA[31: 0]	-	0	-	ns	

Note:

- When the external load capacitance C_L = 30 pF

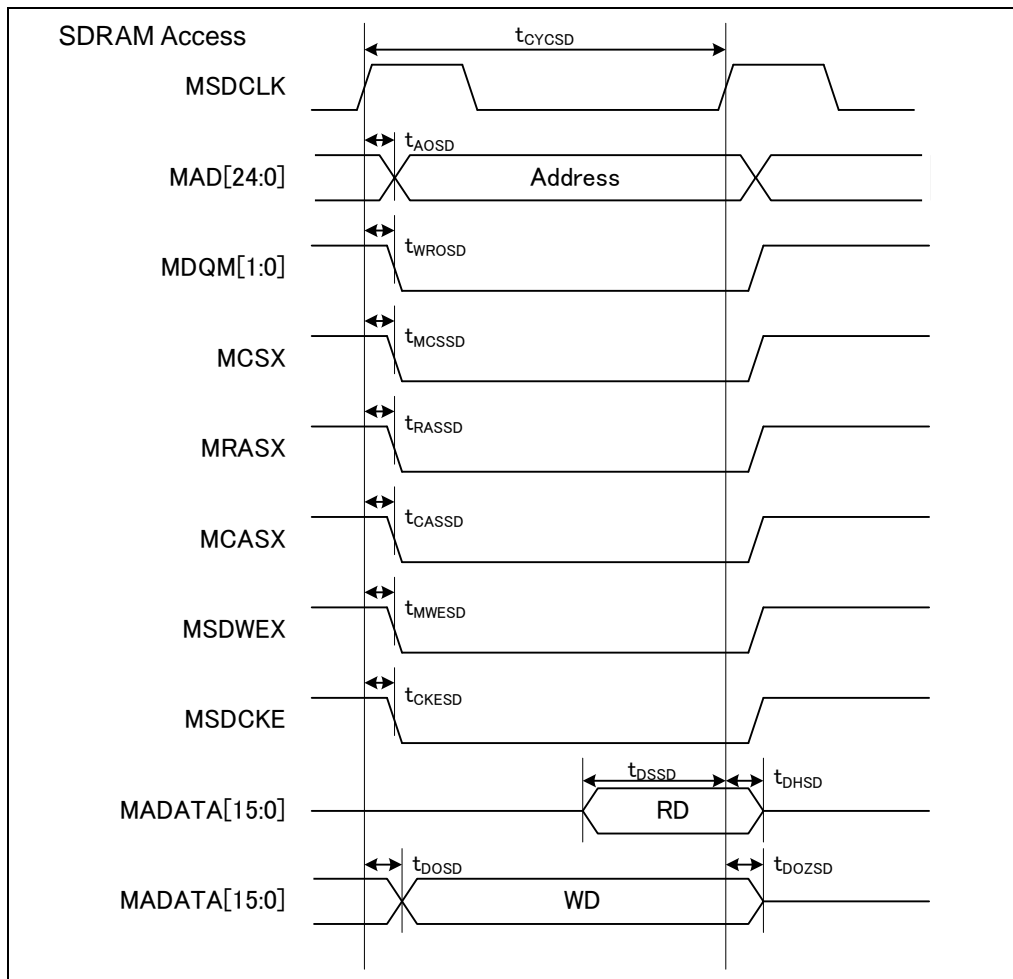

14.4.11 Base Timer Input Timing

Timer Input Timing

($V_{CC} = 2.7V$ to $5.5V$, $V_{SS} = 0V$)

Parameter	Symbol	Pin Name	Condi tions	Value		Unit	Remarks
				Min	Max		
Input pulse width	t_{TIWH} , t_{TIWL}	TIOAn/TIOBn (when using as ECK, TIN)	-	$2t_{CYCP}$	-	ns	

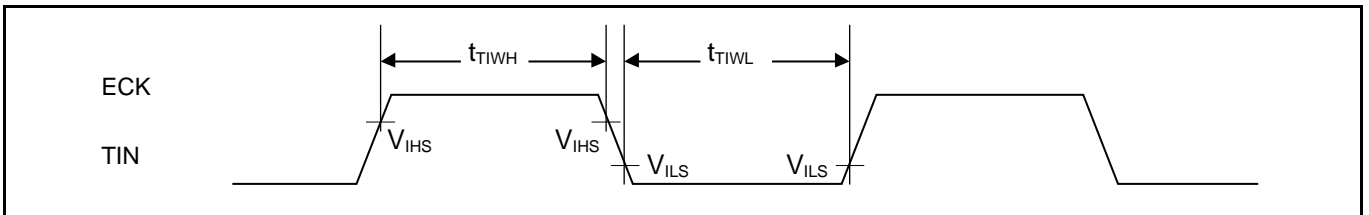

Trigger Input Timing

($V_{CC} = 2.7V$ to $5.5V$, $V_{SS} = 0V$)

Parameter	Symbol	Pin Name	Condi tions	Value		Unit	Remarks
				Min	Max		
Input pulse width	t_{TRGH} , t_{TRGL}	TIOAn/TIOBn (when using as TGIN)	-	$2t_{CYCP}$	-	ns	

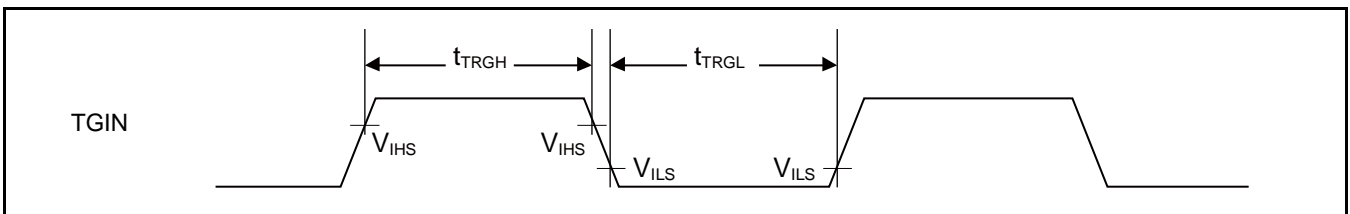

Note:

- t_{CYCP} indicates the APB bus clock cycle time. For more information about the APB bus number to which the base timer is connected, see "10. Block Diagram" in this data sheet.

14.4.12 CSIO (SPI) Timing

Synchronous serial (SPI = 0, SCINV = 0)

($V_{CC} = 2.7V$ to $5.5V$, $V_{SS} = 0V$)

Parameter	Symbol	Pin Name	Conditions	$V_{CC} < 4.5V$		$V_{CC} \geq 4.5V$		Unit
				Min	Max	Min	Max	
Baud rate	-	-		-	8	-	8	Mbps
Serial clock cycle time	t_{SCYC}	SCKx	Internal shift clock operation	$4t_{CYCP}$	-	$4t_{CYCP}$	-	ns
SCK \downarrow →SOT delay time	t_{SLOVI}	SCKx, SOTx		- 30	+ 30	- 20	+ 20	ns
SIN→SCK \uparrow setup time	t_{IVSHI}	SCKx, SINx		50	-	30	-	ns
SCK \uparrow →SIN hold time	t_{SHIXI}	SCKx, SINx		0	-	0	-	ns
Serial clock "L" pulse width	t_{SLSH}	SCKx		$2t_{CYCP} - 10$	-	$2t_{CYCP} - 10$	-	ns
Serial clock "H" pulse width	t_{SHSL}	SCKx	$t_{CYCP} + 10$	-	$t_{CYCP} + 10$	-	ns	
SCK \downarrow →SOT delay time	t_{SLOVE}	SCKx, SOTx	External shift clock operation	-	50	-	30	ns
SIN→SCK \uparrow setup time	t_{IVSHE}	SCKx, SINx		10	-	10	-	ns
SCK \uparrow →SIN hold time	t_{SHIXE}	SCKx, SINx		20	-	20	-	ns
SCK fall time	tF	SCKx		-	5	-	5	ns
SCK rise time	tR	SCKx		-	5	-	5	ns

Notes:

- The above characteristics apply to CLK synchronous mode.
- t_{CYCP} indicates the APB bus clock cycle time. For more information about the APB bus number to which the multi-function serial is connected, see "10. Block Diagram" in this data sheet.
- These characteristics only guarantee the same relocate port number; for example, the combination of SCLKx_0 and SOTx_1 is not guaranteed.
- When the external load capacitance $C_L = 30$ pF.

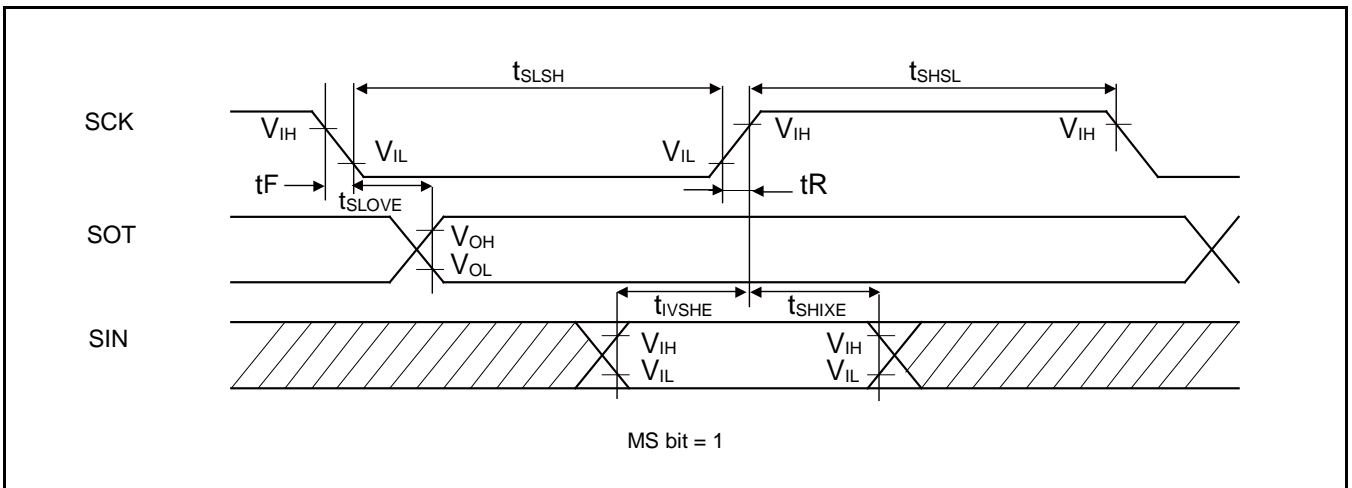
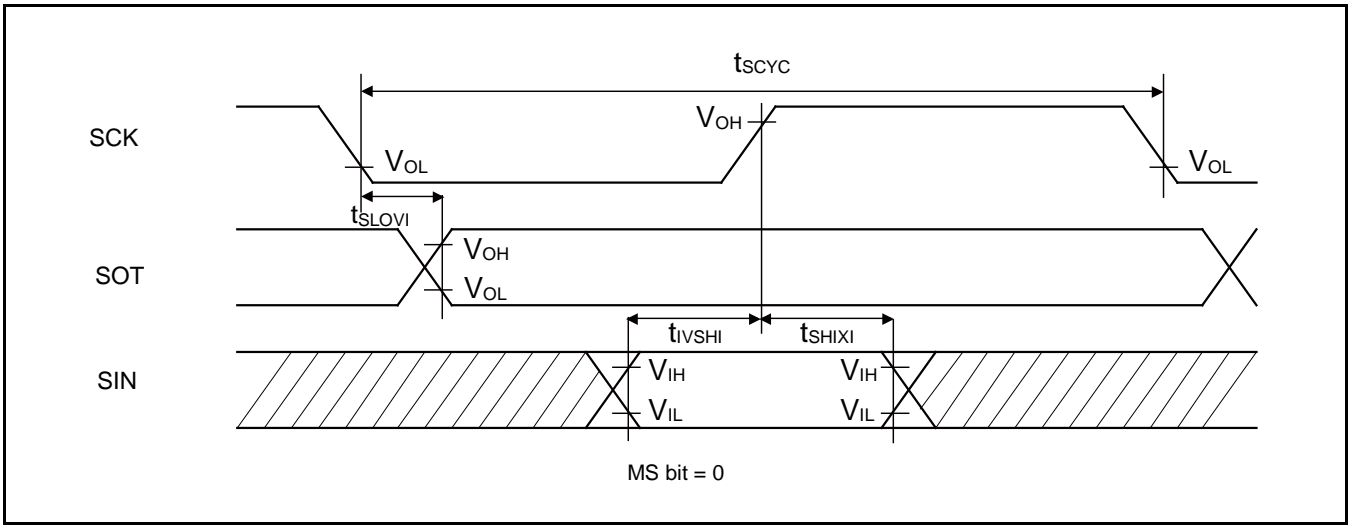

Synchronous Serial (SPI = 0, SCINV = 1)

(V_{CC} = 2.7V to 5.5V, V_{SS} = 0V)

Parameter	Symbol	Pin Name	Conditions	V _{CC} < 4.5V		V _{CC} ≥ 4.5V		Unit
				Min	Max	Min	Max	
Baud rate	-	-	-	-	8	-	8	Mbps
Serial clock cycle time	t _{SCYC}	SCKx	Internal shift clock operation	4t _{CYCP}	-	4t _{CYCP}	-	ns
SCK↑→SOT delay time	t _{SHOVI}	SCKx, SOTx		- 30	+ 30	- 20	+ 20	ns
SIN→SCK↓ setup time	t _{IVSLI}	SCKx, SINx		50	-	30	-	ns
SCK↓→SIN hold time	t _{SLIXI}	SCKx, SINx		0	-	0	-	ns
Serial clock "L" pulse width	t _{SLSH}	SCKx		2t _{CYCP} - 10	-	2t _{CYCP} - 10	-	ns
Serial clock "H" pulse width	t _{SHSL}	SCKx	t _{CYCP} + 10	-	t _{CYCP} + 10	-	ns	
SCK↑→SOT delay time	t _{SHOVE}	SCKx, SOTx	External shift clock operation	-	50	-	30	ns
SIN→SCK↓ setup time	t _{IVSLE}	SCKx, SINx		10	-	10	-	ns
SCK↓→SIN hold time	t _{SLIXE}	SCKx, SINx		20	-	20	-	ns
SCK fall time	t _F	SCKx		-	5	-	5	ns
SCK rise time	t _R	SCKx		-	5	-	5	ns

Notes:

- The above characteristics apply to CLK synchronous mode.
- t_{CYCP} indicates the APB bus clock cycle time. For more information about the APB bus number to which the multi-function serial is connected, see "10. Block Diagram" in this data sheet.
- These characteristics only guarantee the same relocate port number; for example, the combination of SCLKx_0 and SOTx_1 is not guaranteed.
- When the external load capacitance C_L = 30 pF.

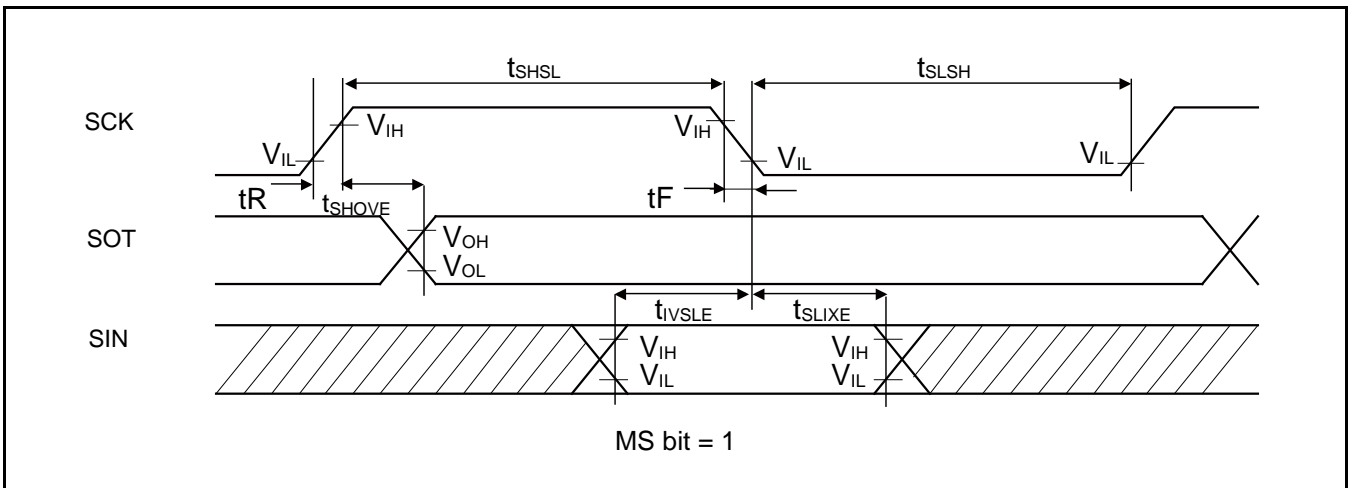
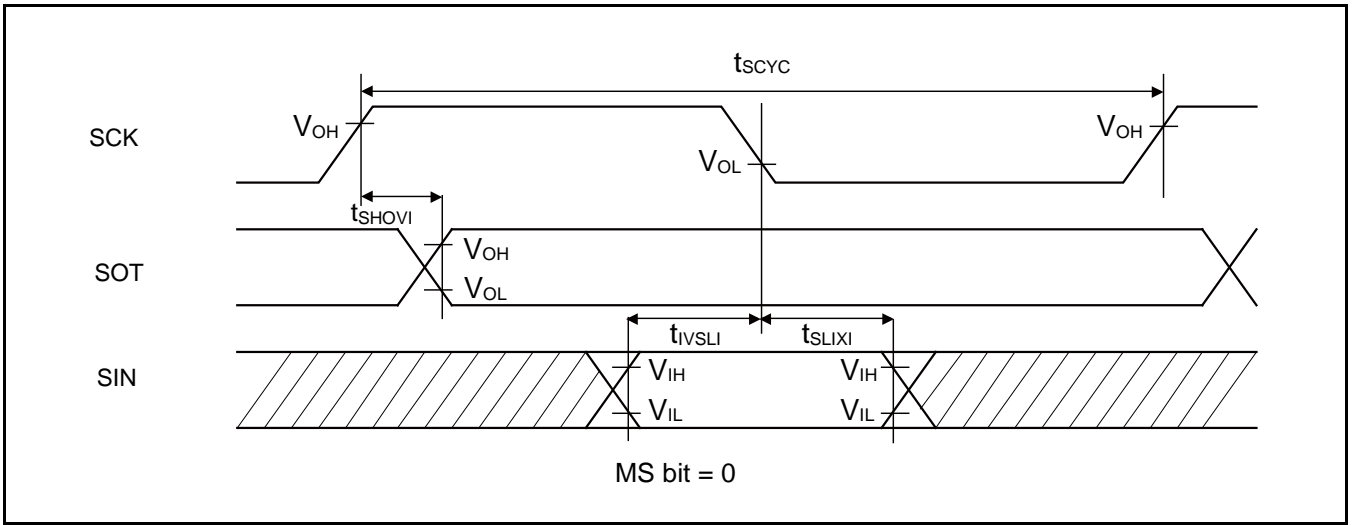

Synchronous Serial (SPI = 1, SCINV = 0)

(V_{CC} = 2.7V to 5.5V, V_{SS} = 0V)

Parameter	Symbol	Pin Name	Conditions	V _{CC} < 4.5V		V _{CC} ≥ 4.5V		Unit
				Min	Max	Min	Max	
Baud rate	-	-	-	-	8	-	8	Mbps
Serial clock cycle time	t _{SCYC}	SCKx	Internal shift clock operation	4t _{CYCP}	-	4t _{CYCP}	-	ns
SCK↑→SOT delay time	t _{SHOVI}	SCKx, SOTx		- 30	+ 30	- 20	+ 20	ns
SIN→SCK↓ setup time	t _{IVSLI}	SCKx, SINx		50	-	30	-	ns
SCK↓→SIN hold time	t _{SLIXI}	SCKx, SINx		0	-	0	-	ns
SOT→SCK↓ delay time	t _{SOVLI}	SCKx, SOTx		2t _{CYCP} - 30	-	2t _{CYCP} - 30	-	ns
Serial clock "L" pulse width	t _{SLSH}	SCKx		2t _{CYCP} - 10	-	2t _{CYCP} - 10	-	ns
Serial clock "H" pulse width	t _{SHSL}	SCKx	t _{CYCP} + 10	-	t _{CYCP} + 10	-	ns	
SCK↑→SOT delay time	t _{SHOVE}	SCKx, SOTx	External shift clock operation	-	50	-	30	ns
SIN→SCK↓ setup time	t _{IVSLE}	SCKx, SINx		10	-	10	-	ns
SCK↓→SIN hold time	t _{SLIXE}	SCKx, SINx		20	-	20	-	ns
SCK fall time	t _F	SCKx		-	5	-	5	ns
SCK rise time	t _R	SCKx		-	5	-	5	ns

Notes:

- The above characteristics apply to CLK synchronous mode.
- t_{CYCP} indicates the APB bus clock cycle time. For more information about the APB bus number to which the multi-function serial is connected, see "10. Block Diagram" in this data sheet.
- These characteristics only guarantee the same relocate port number; for example, the combination of SCLKx_0 and SOTx_1 is not guaranteed.
- When the external load capacitance C_L = 30 pF.

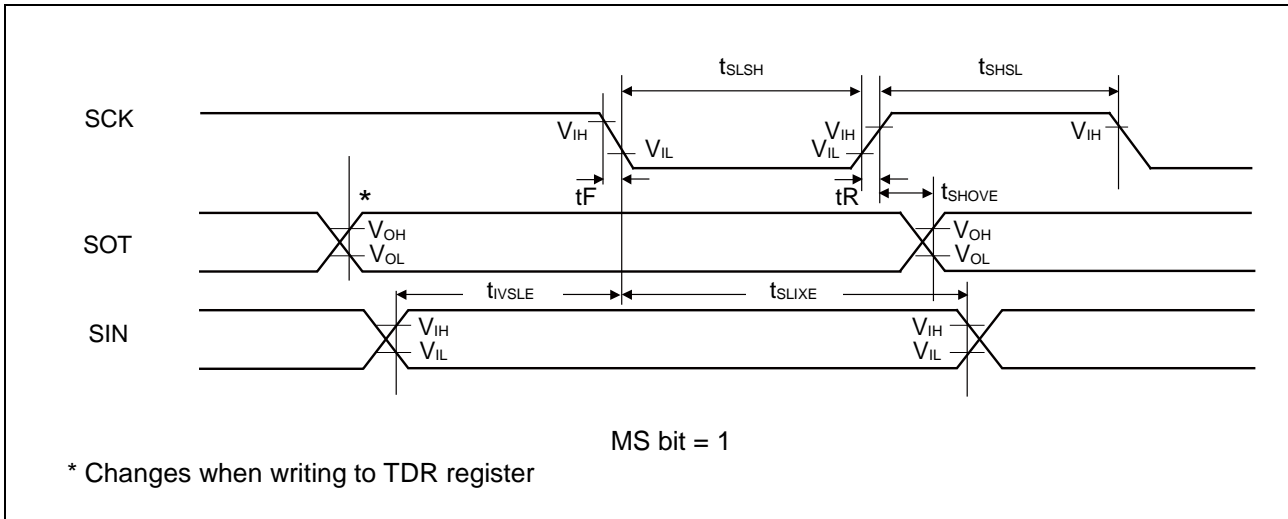
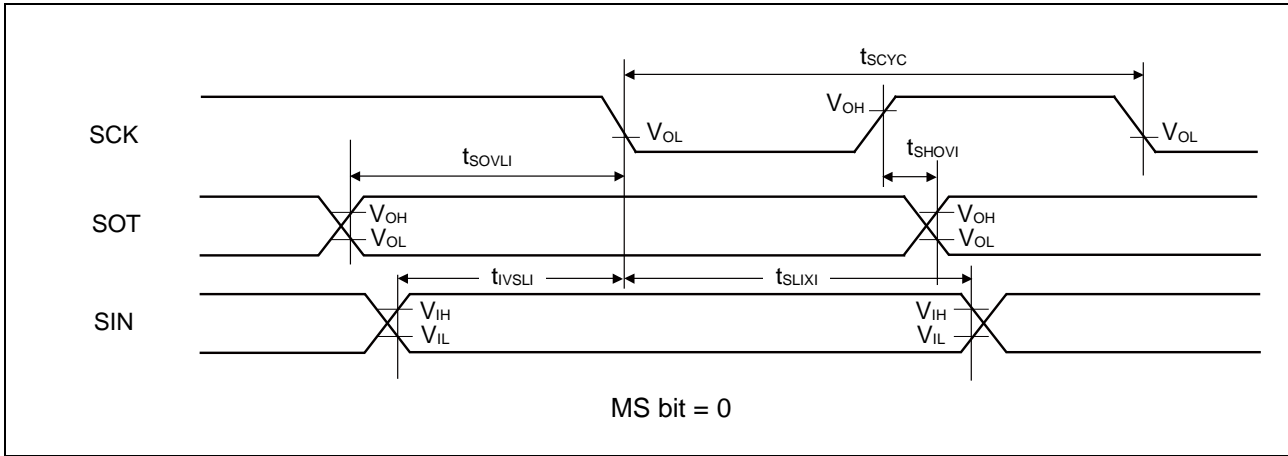

Synchronous Serial (SPI = 1, SCINV = 1)

(V_{CC} = 2.7V to 5.5V, V_{SS} = 0V)

Parameter	Symbol	Pin Name	Conditions	V _{CC} < 4.5V		V _{CC} ≥ 4.5V		Unit
				Min	Max	Min	Max	
Baud rate	-	-	-	-	8	-	8	Mbps
Serial clock cycle time	t _{SCYC}	SCKx	Internal shift clock operation	4t _{CYCP}	-	4t _{CYCP}	-	ns
SCK↓→SOT delay time	t _{SLOVI}	SCKx, SOTx		- 30	+ 30	- 20	+ 20	ns
SIN→SCK↑ setup time	t _{IVSHI}	SCKx, SINx		50	-	30	-	ns
SCK↑→SIN hold time	t _{SHIXI}	SCKx, SINx		0	-	0	-	ns
SOT→SCK↑ delay time	t _{SOVHI}	SCKx, SOTx		2t _{CYCP} - 30	-	2t _{CYCP} - 30	-	ns
Serial clock "L" pulse width	t _{SLSH}	SCKx		2t _{CYCP} - 10	-	2t _{CYCP} - 10	-	ns
Serial clock "H" pulse width	t _{SHSL}	SCKx	t _{CYCP} + 10	-	t _{CYCP} + 10	-	ns	
SCK↓→SOT delay time	t _{SLOVE}	SCKx, SOTx	External shift clock operation	-	50	-	30	ns
SIN→SCK↑ setup time	t _{IVSHE}	SCKx, SINx		10	-	10	-	ns
SCK↑→SIN hold time	t _{SHIXE}	SCKx, SINx		20	-	20	-	ns
SCK fall time	t _F	SCKx		-	5	-	5	ns
SCK rise time	t _R	SCKx		-	5	-	5	ns

Notes:

- The above characteristics apply to CLK synchronous mode.
- t_{CYCP} indicates the APB bus clock cycle time. For more information about the APB bus number to which the multi-function serial is connected, see "10. Block Diagram" in this data sheet.
- These characteristics only guarantee the same relocate port number; for example, the combination of SCLKx_0 and SOTx_1 is not guaranteed.
- When the external load capacitance C_L = 30 pF.

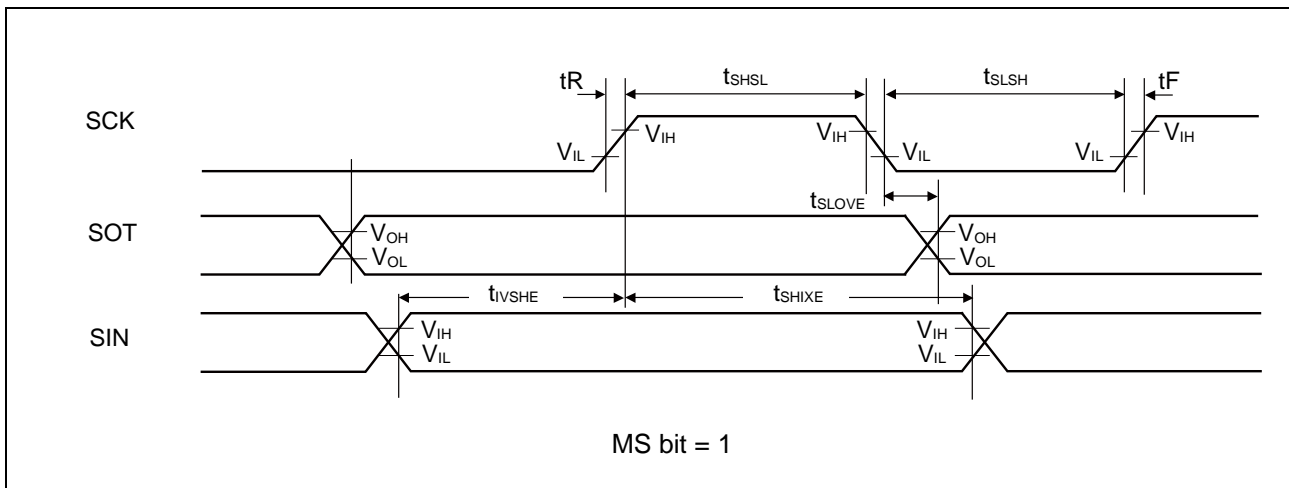
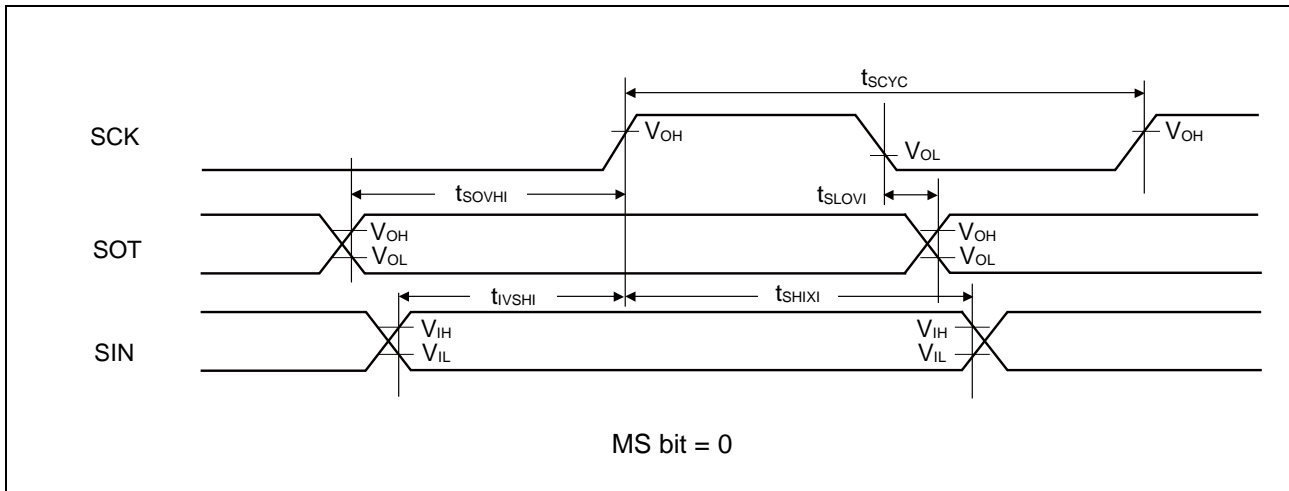

When Using Synchronous Serial Chip Select (SPI = 1, SCINV = 0, MS = 0, CSLVL = 1)
(V_{CC} = 2.7V to 5.5V, V_{SS} = 0V)

Parameter	Symbol	Conditions	V _{CC} < 4.5V		V _{CC} ≥ 4.5V		Unit
			Min	Max	Min	Max	
SCS↓→SCK↓ setup time	t _{CSSI}	Internal shift clock operation	(*1)-50	(*1)+0	(*1)-50	(*1)+0	ns
SCK↑→SCS↑ hold time	t _{CShI}		(*2)+0	(*2)+50	(*2)+0	(*2)+50	ns
SCS deselect time	t _{CSDI}		(*3)-50 +5t _{CYCP}	(*3)+50 +5t _{CYCP}	(*3)-50 +5t _{CYCP}	(*3)+50 +5t _{CYCP}	ns
SCS↓→SCK↓ setup time	t _{CSE}	External shift clock operation	3t _{CYCP} +30	-	3t _{CYCP} +30	-	ns
SCK↑→SCS↑ hold time	t _{CSE}		0	-	0	-	ns
SCS deselect time	t _{CSE}		3t _{CYCP} +30	-	3t _{CYCP} +30	-	ns
SCS↓→SOT delay time	t _{DSE}		-	40	-	40	ns
SCS↑→SOT delay time	t _{DEE}		0	-	0	-	ns

(*1) : CSSU bit value serial chip select timing operating clock cycle [ns]

(*2) : CSHD bit value serial chip select timing operating clock cycle [ns]

(*3) : CSDS bit value serial chip select timing operating clock cycle [ns]

Notes:

- t_{CYCP} indicates the APB bus clock cycle time. For more information about the APB bus number to which the multi-function serial is connected, see "10. Block Diagram" in this data sheet.
- For more information about CSSU, CSHD, CSDS, and the serial chip select timing operating clock, see "FM4 Family Peripheral Manual Main Part (MN709-00001)."
- When the external load capacitance C_L = 30 pF.

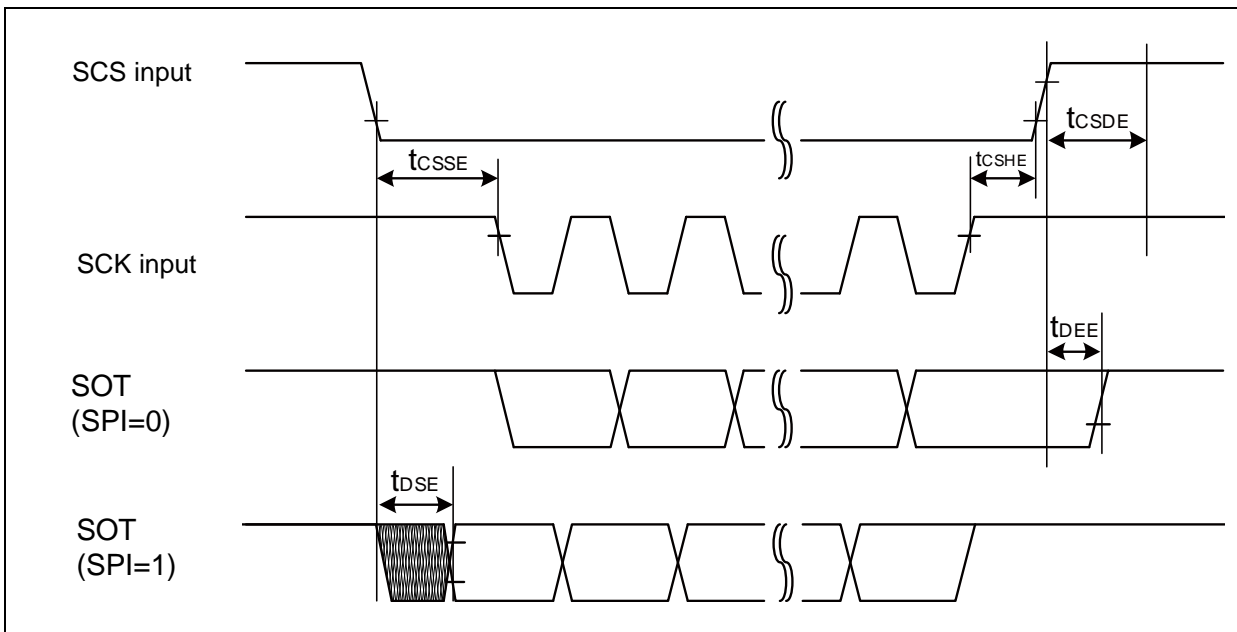
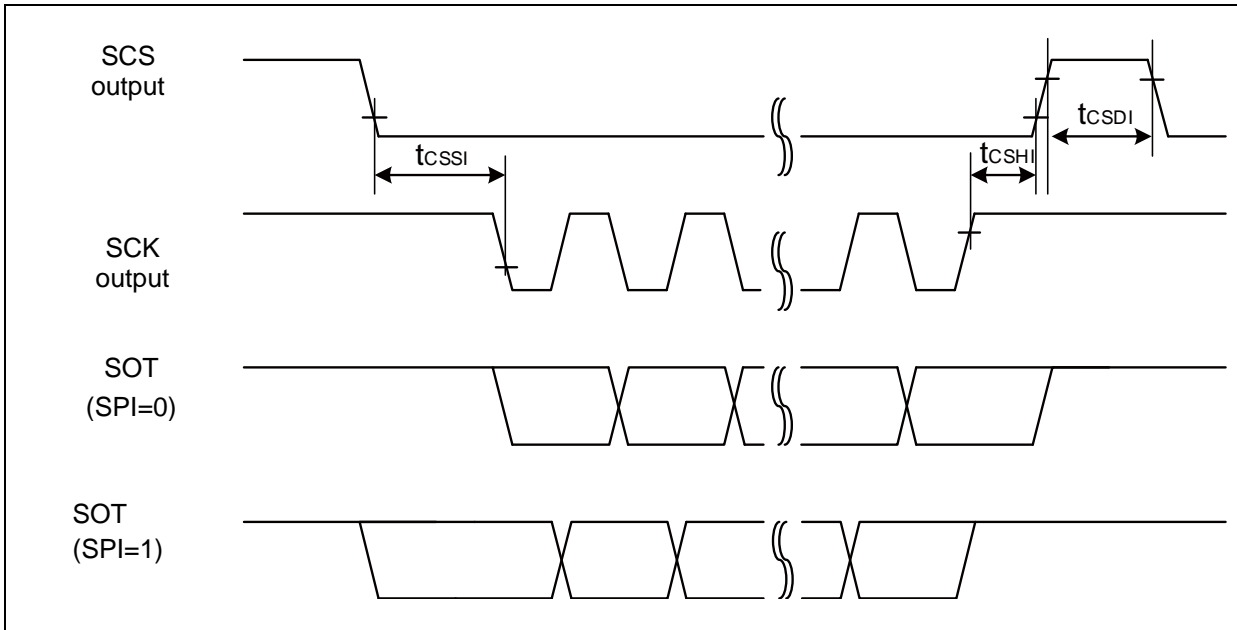

When Using Synchronous Serial Chip Select (SPI = 1, SCINV = 1, MS = 0, CSLVL = 1)
(V_{CC} = 2.7V to 5.5V, V_{SS} = 0V)

Parameter	Symbol	Conditions	V _{CC} < 4.5V		V _{CC} ≥ 4.5V		Unit
			Min	Max	Min	Max	
SCS↓→SCK↓ setup time	t _{CSSI}	Internal shift clock operation	(*1)-50	(*1)+0	(*1)-50	(*1)+0	ns
SCK↑→SCS↑ hold time	t _{CShI}		(*2)+0	(*2)+50	(*2)+0	(*2)+50	ns
SCS deselect time	t _{CSDI}		(*3)-50 +5t _{CYCP}	(*3)+50 +5t _{CYCP}	(*3)-50 +5t _{CYCP}	(*3)+50 +5t _{CYCP}	ns
SCS↓→SCK↓ setup time	t _{CSSE}	External shift clock operation	3t _{CYCP} +30	-	3t _{CYCP} +30	-	ns
SCK↑→SCS↑ hold time	t _{CSHE}		0	-	0	-	ns
SCS deselect time	t _{CSDE}		3t _{CYCP} +30	-	3t _{CYCP} +30	-	ns
SCS↓→SOT delay time	t _{DSE}		-	40	-	40	ns
SCS↑→SOT delay time	t _{DEE}		0	-	0	-	ns

(*1) : CSSU bit value serial chip select timing operating clock cycle [ns]

(*2) : CSHD bit value serial chip select timing operating clock cycle [ns]

(*3) : CSDS bit value serial chip select timing operating clock cycle [ns]

Notes:

- t_{CYCP} indicates the APB bus clock cycle time. For more information about the APB bus number to which the multi-function serial is connected, see "10. Block Diagram" in this data sheet.
- For more information about CSSU, CSHD, CSDS, and the serial chip select timing operating clock, see "FM4 Family Peripheral Manual Main Part (MN709-00001)."
- When the external load capacitance C_L = 30 pF.

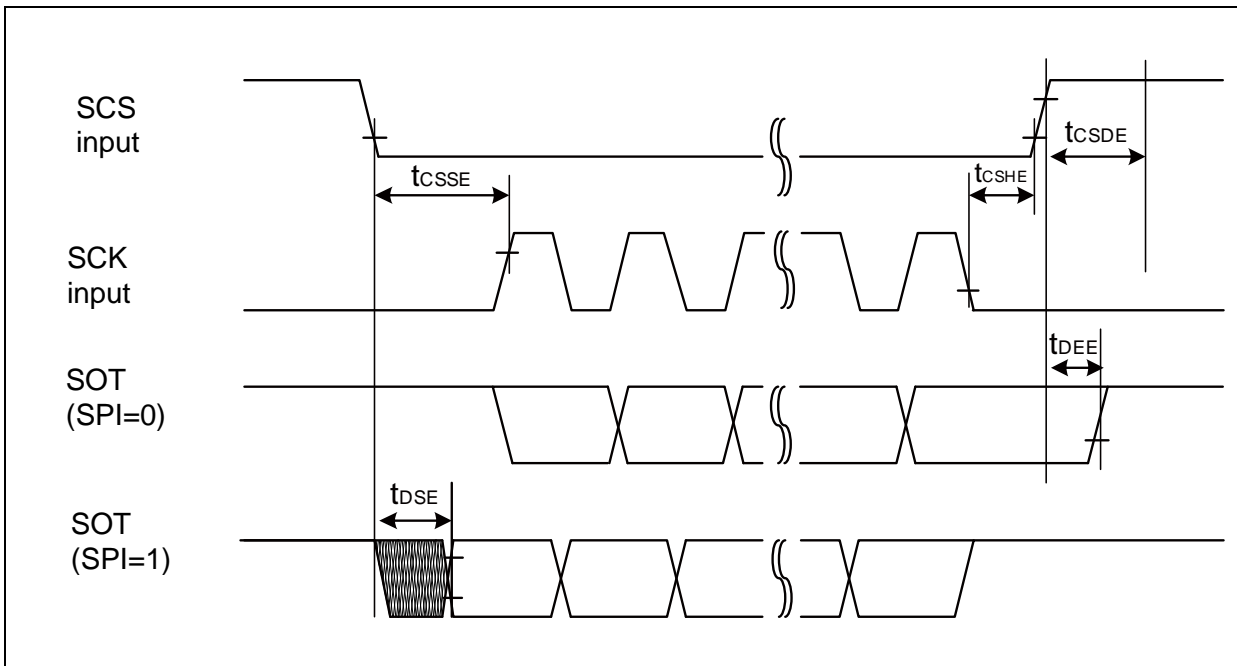
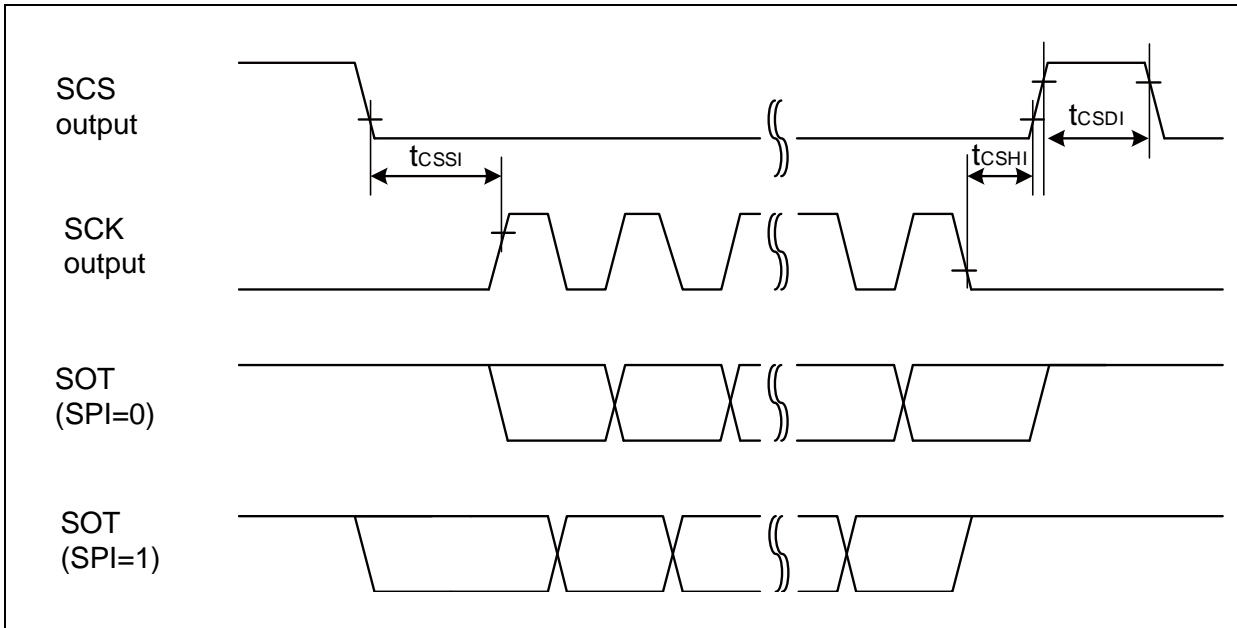

When Using Synchronous Serial Chip Select (SPI = 1, SCINV = 0, MS = 0, CSLVL = 0)

(V_{CC} = 2.7V to 5.5V, V_{SS} = 0V)

Parameter	Symbol	Conditions	V _{CC} < 4.5V		V _{CC} ≥ 4.5V		Unit
			Min	Max	Min	Max	
SCS↑→SCK↓ setup time	t _{CSSI}	Internal shift clock operation	(*1)-50	(*1)+0	(*1)-50	(*1)+0	ns
SCK↑→SCS↓ hold time	t _{CSHI}		(*2)+0	(*2)+50	(*2)+0	(*2)+50	ns
SCS deselect time	t _{CSDI}		(*3)-50 +5t _{CYCP}	(*3)+50 +5t _{CYCP}	(*3)-50 +5t _{CYCP}	(*3)+50 +5t _{CYCP}	ns
SCS↑→SCK↓ setup time	t _{CSSE}	External shift clock operation	3t _{CYCP} +30	-	3t _{CYCP} +30	-	ns
SCK↑→SCS↓ hold time	t _{CSHE}		0	-	0	-	ns
SCS deselect time	t _{CSDE}		3t _{CYCP} +30	-	3t _{CYCP} +30	-	ns
SCS↑→SOT delay time	t _{DSE}		-	40	-	40	ns
SCS↓→SOT delay time	t _{DEE}		0	-	0	-	ns

(*1) : CSSU bit value serial chip select timing operating clock cycle [ns]

(*2) : CSHD bit value serial chip select timing operating clock cycle [ns]

(*3) : CSDS bit value serial chip select timing operating clock cycle [ns]

Notes:

- t_{CYCP} indicates the APB bus clock cycle time. For more information about the APB bus number to which the multi-function serial is connected, see "10. Block Diagram" in this data sheet.
- For more information about CSSU, CSHD, CSDS, and the serial chip select timing operating clock, see "FM4 Family Peripheral Manual Main Part (MN709-00001)."
- When the external load capacitance C_L = 30 pF.

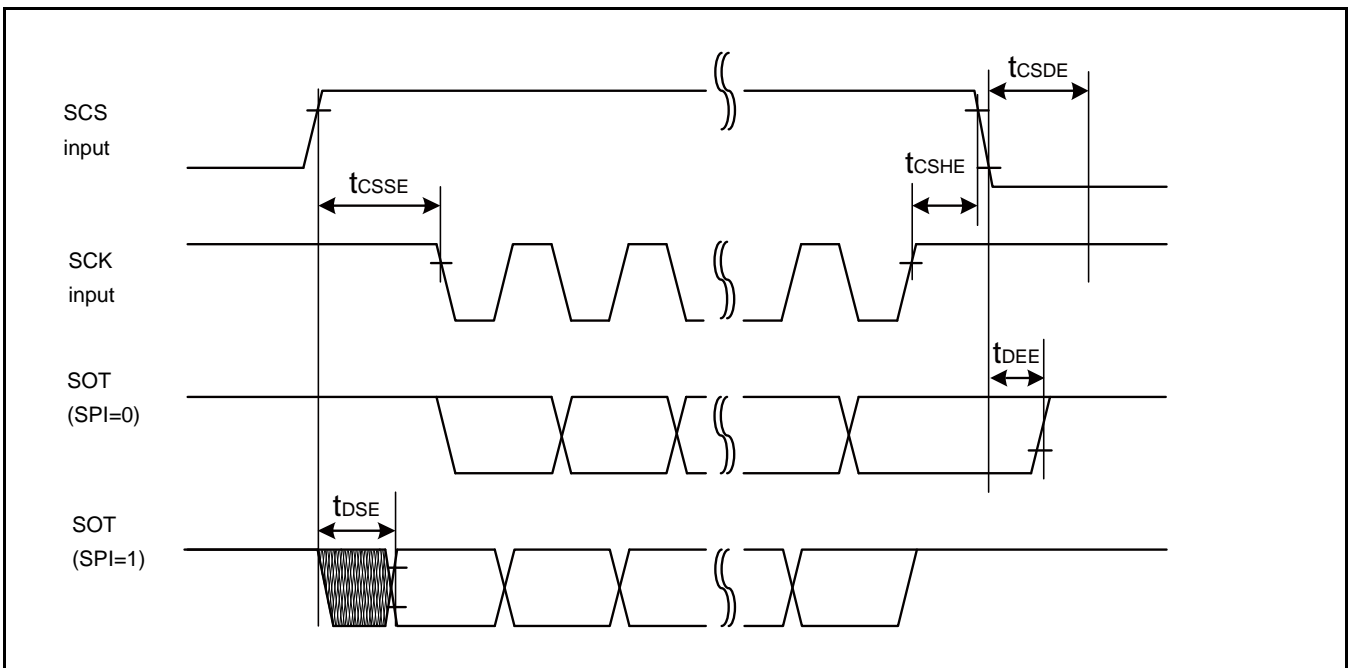
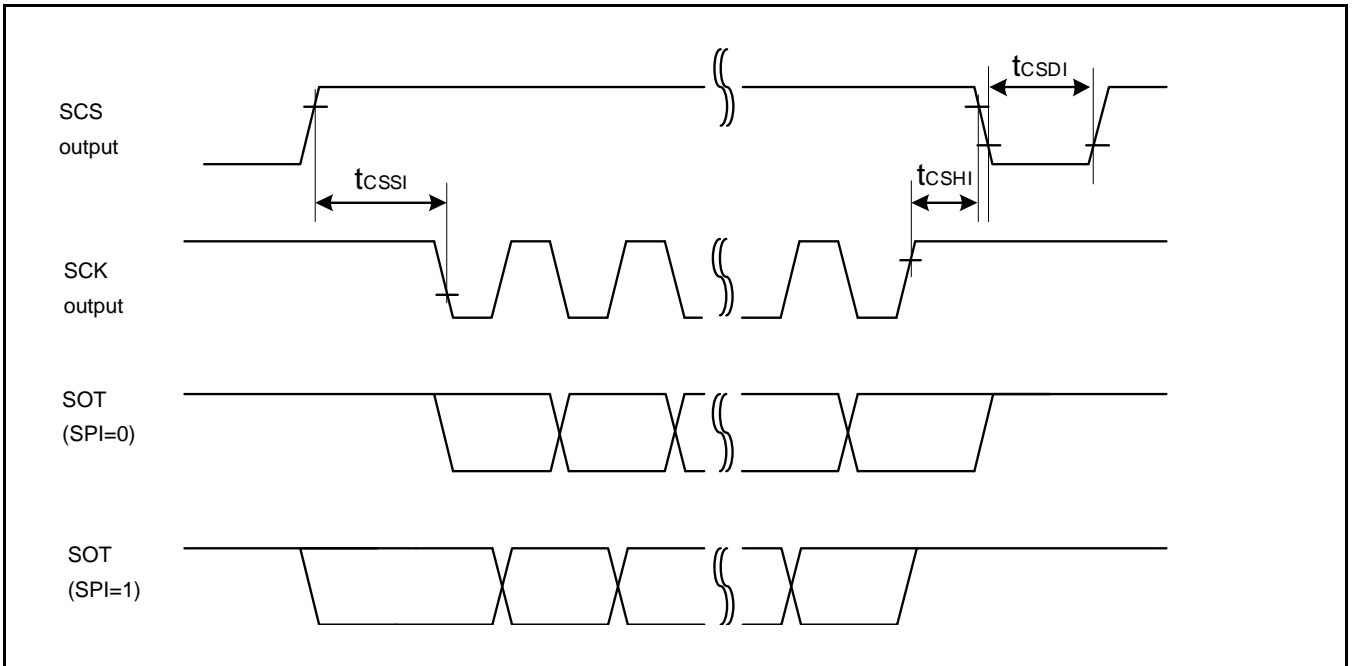

When Using Synchronous Serial Chip Select (SPI = 1, SCINV = 1, MS = 0, CSLVL = 0)

(V_{CC} = 2.7V to 5.5V, V_{SS} = 0V)

Parameter	Symbol	Conditions	V _{CC} < 4.5V		V _{CC} ≥ 4.5V		Units
			Min	Max	Min	Max	
SCS ↑ → SCK ↑ setup time	t _{CSSI}	Internal shift clock operation	(*1)-50	(*1)+0	(*1)-50	(*1)+0	ns
SCK ↓ → SCS ↓ hold time	t _{CSHI}		(*2)+0	(*2)+50	(*2)+0	(*2)+50	ns
SCS deselect time	t _{CSDI}		(*3)-50 +5t _{CYCP}	(*3)+50 +5t _{CYCP}	(*3)-50 +5t _{CYCP}	(*3)+50 +5t _{CYCP}	ns
SCS ↑ → SCK ↑ setup time	t _{CSSE}	External shift clock operation	3t _{CYCP} +30	-	3t _{CYCP} +30	-	ns
SCK ↓ → SCS ↓ hold time	t _{CSHE}		0	-	0	-	ns
SCS deselect time	t _{CSDE}		3t _{CYCP} +30	-	3t _{CYCP} +30	-	ns
SCS ↑ → SOT delay time	t _{DSE}		-	40	-	40	ns
SCS ↓ → SOT delay time	t _{DEE}		0	-	0	-	ns

(*1) : CSSU bit value x serial chip select timing operating clock cycle [ns]

(*2) : CSHD bit value x serial chip select timing operating clock cycle [ns]

(*3) : CSDS bit value x serial chip select timing operating clock cycle [ns]

Notes:

- t_{CYCP} indicates the APB bus clock cycle time. For more information about the APB bus number to which the multi-function serial is connected, see "10. Block Diagram" in this data sheet.
- For more information about CSSU, CSHD, CSDS, and the serial chip select timing operating clock, see "FM4 Family Peripheral Manual Main Part (MN709-00001)."
- When the external load capacitance C_L = 30 pF.

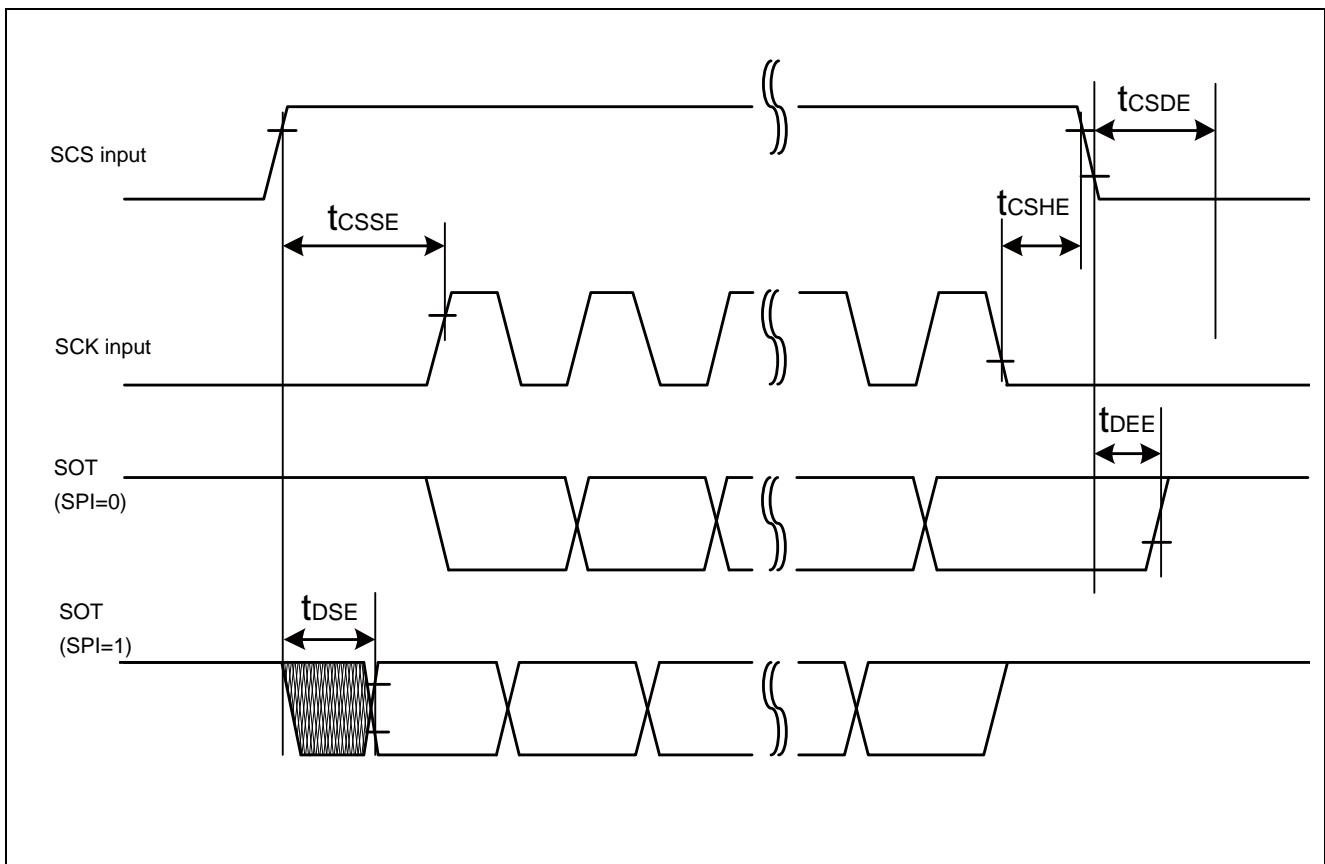
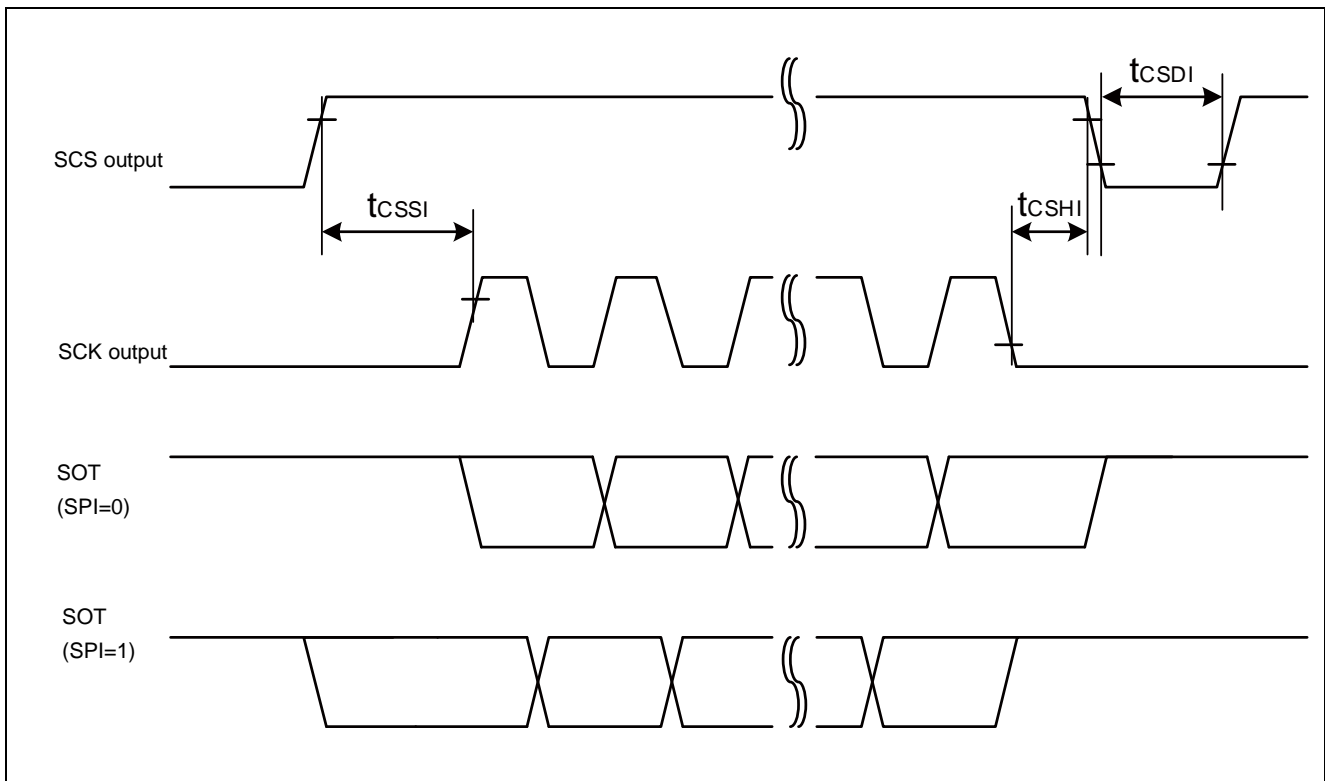

High-Speed Synchronous Serial (SPI = 0, SCINV = 0)

(V_{CC} = 2.7V to 5.5V, V_{SS} = 0V)

Parameter	Symbol	Pin Name	Conditions	V _{CC} < 4.5V		V _{CC} ≥ 4.5V		Unit
				Min	Max	Min	Max	
Baud rate	-	-	-	-	25	-	25	Mbps
Serial clock cycle time	t _{SCYC}	SCKx	Internal shift clock operation	4t _{CYCP}	-	4t _{CYCP}	-	ns
SCK↓→SOT delay time	t _{SLOVI}	SCKx, SOTx		- 10	+ 10	- 10	+ 10	ns
SIN→SCK↑ setup time	t _{IVSHI}	SCKx, SINx		14	-	12.5	-	ns
				12.5*				
SCK↑→SIN hold time	t _{SHIXI}	SCKx, SINx		5	-	5	-	ns
Serial clock "L" pulse width	t _{SLSH}	SCKx	External shift clock operation	2t _{CYCP} - 5	-	2t _{CYCP} - 5	-	ns
Serial clock "H" pulse width	t _{SHSL}	SCKx		t _{CYCP} + 10	-	t _{CYCP} + 10	-	ns
SCK↓→SOT delay time	t _{SLOVE}	SCKx, SOTx		-	15	-	15	ns
SIN→SCK↑ setup time	t _{IVSHE}	SCKx, SINx		5	-	5	-	ns
SCK↑→SIN hold time	t _{SHIXE}	SCKx, SINx		5	-	5	-	ns
SCK fall time	t _F	SCKx		-	5	-	5	ns
SCK rise time	t _R	SCKx		-	5	-	5	ns

Notes:

- The above characteristics apply to CLK synchronous mode.
- t_{CYCP} indicates the APB bus clock cycle time. For more information about the APB bus number to which the multi-function serial is connected, see "10. Block Diagram" in this data sheet.
- These characteristics only guarantee the following pins:
 No chip select: SIN4_0, SOT4_0, SCK4_0
 Chip select: SIN6_0, SOT6_0, SCK6_0, SCS60_0, SCS61_0, SCS62_0, SCS63_0
- When the external load capacitance C_L = 30 pF. (For *, when C_L = 10 pF)

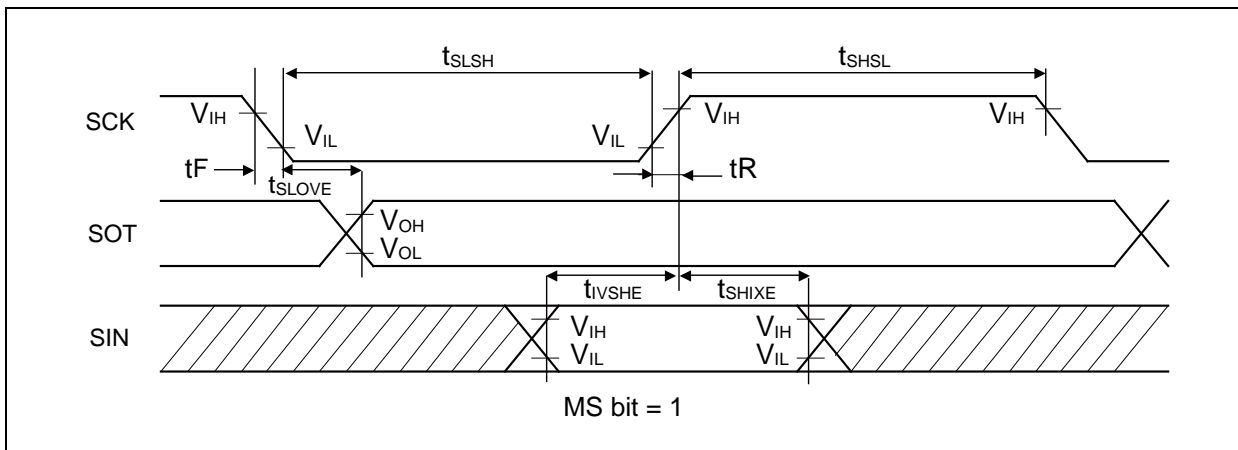
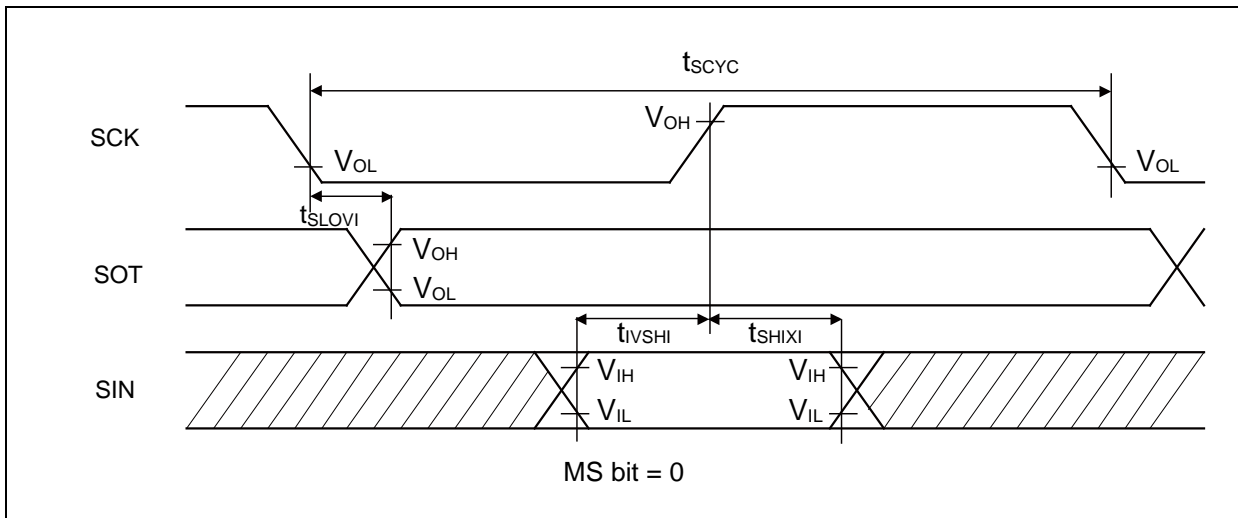

High-Speed Synchronous Serial (SPI = 0, SCINV = 1)

(V_{CC} = 2.7V to 5.5V, V_{SS} = 0V)

Parameter	Symbol	Pin Name	Conditions	V _{CC} < 4.5V		V _{CC} ≥ 4.5V		Unit
				Min	Max	Min	Max	
Baud rate	-	-	-	-	25	-	25	Mbps
Serial clock cycle time	t _{SCYC}	SCKx	Internal shift clock operation	4t _{CYCP}	-	4t _{CYCP}	-	ns
SCK↑→SOT delay time	t _{SHOVI}	SCKx, SOTx		- 10	+ 10	- 10	+ 10	ns
SIN→SCK↓ setup time	t _{IVSLI}	SCKx, SINx		14	-	12.5	-	ns
				12.5*				
SCK↓→SIN hold time	t _{SLIXI}	SCKx, SINx		5	-	5	-	ns
Serial clock "L" pulse width	t _{SLSH}	SCKx	External shift clock operation	2t _{CYCP} - 5	-	2t _{CYCP} - 5	-	ns
Serial clock "H" pulse width	t _{SHSL}	SCKx		t _{CYCP} + 10	-	t _{CYCP} + 10	-	ns
SCK↑→SOT delay time	t _{SHOVE}	SCKx, SOTx		-	15	-	15	ns
SIN→SCK↓ setup time	t _{IVSLE}	SCKx, SINx		5	-	5	-	ns
SCK↓→SIN hold time	t _{SLIXE}	SCKx, SINx		5	-	5	-	ns
SCK fall time	t _F	SCKx		-	5	-	5	ns
SCK rise time	t _R	SCKx		-	5	-	5	ns

Notes:

- The above characteristics apply to CLK synchronous mode.
- t_{CYCP} indicates the APB bus clock cycle time. For more information about the APB bus number to which the multi-function serial is connected, see "10. Block Diagram" in this data sheet.
- These characteristics only guarantee the following pins:
 No chip select: SIN4_0, SOT4_0, SCK4_0
 Chip select: SIN6_0, SOT6_0, SCK6_0, SCS60_0, SCS61_0, SCS62_0, SCS63_0
- When the external load capacitance C_L = 30 pF. (For *, when C_L = 10 pF)

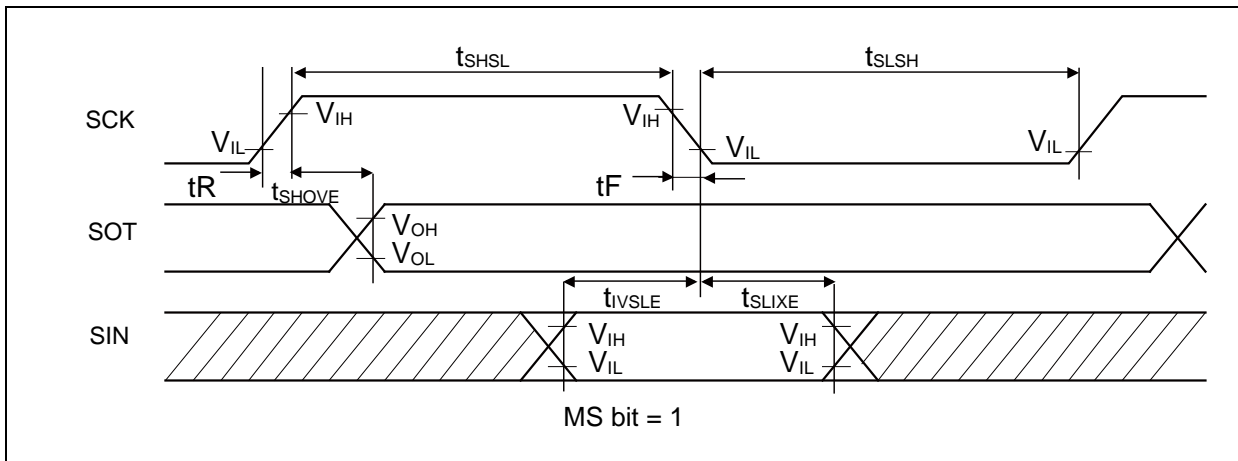
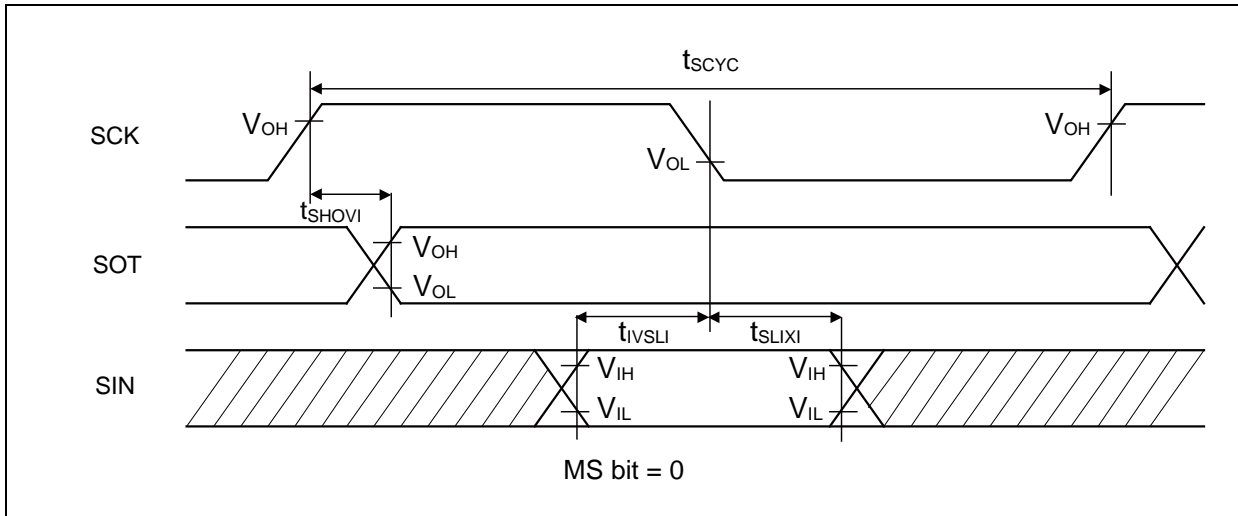

High-Speed Synchronous Serial (SPI = 1, SCINV = 0)

(V_{CC} = 2.7V to 5.5V, V_{SS} = 0V)

Parameter	Symbol	Pin Name	Conditions	V _{CC} < 4.5V		V _{CC} ≥ 4.5V		Unit
				Min	Max	Min	Max	
Baud rate	-	-	-	-	25	-	25	Mbps
Serial clock cycle time	t _{SCYC}	SCKx	Internal shift clock operation	4t _{CYCP}	-	4t _{CYCP}	-	ns
SCK↑→SOT delay time	t _{SHOVI}	SCKx, SOTx		- 10	+ 10	- 10	+ 10	ns
SIN→SCK↓ setup time	t _{IVSLI}	SCKx, SINx		14	-	12.5	-	ns
				12.5*				
SCK↓→SIN hold time	t _{SLIXI}	SCKx, SINx		5	-	5	-	ns
SOT→SCK↓ delay time	t _{SOVLI}	SCKx, SOTx		2t _{CYCP} - 10	-	2t _{CYCP} - 10	-	ns
Serial clock "L" pulse width	t _{SLSH}	SCKx		2t _{CYCP} - 5	-	2t _{CYCP} - 5	-	ns
Serial clock "H" pulse width	t _{SHSL}	SCKx	t _{CYCP} + 10	-	t _{CYCP} + 10	-	ns	
SCK↑→SOT delay time	t _{SHOVE}	SCKx, SOTx	External shift clock operation	-	15	-	15	ns
SIN→SCK↓ setup time	t _{IVSLE}	SCKx, SINx		5	-	5	-	ns
SCK↓→SIN hold time	t _{SLIXE}	SCKx, SINx		5	-	5	-	ns
SCK fall time	t _F	SCKx		-	5	-	5	ns
SCK rise time	t _R	SCKx		-	5	-	5	ns

Notes:

- The above characteristics apply to CLK synchronous mode.
- t_{CYCP} indicates the APB bus clock cycle time. For more information about the APB bus number to which the multi-function serial is connected, see "10. Block Diagram" in this data sheet.
- These characteristics only guarantee the following pins:
 No chip select: SIN4_0, SOT4_0, SCK4_0
 Chip select: SIN6_0, SOT6_0, SCK6_0, SCS60_0, SCS61_0, SCS62_0, SCS63_0
- When the external load capacitance C_L = 30 pF. (for *, when C_L = 10 pF)

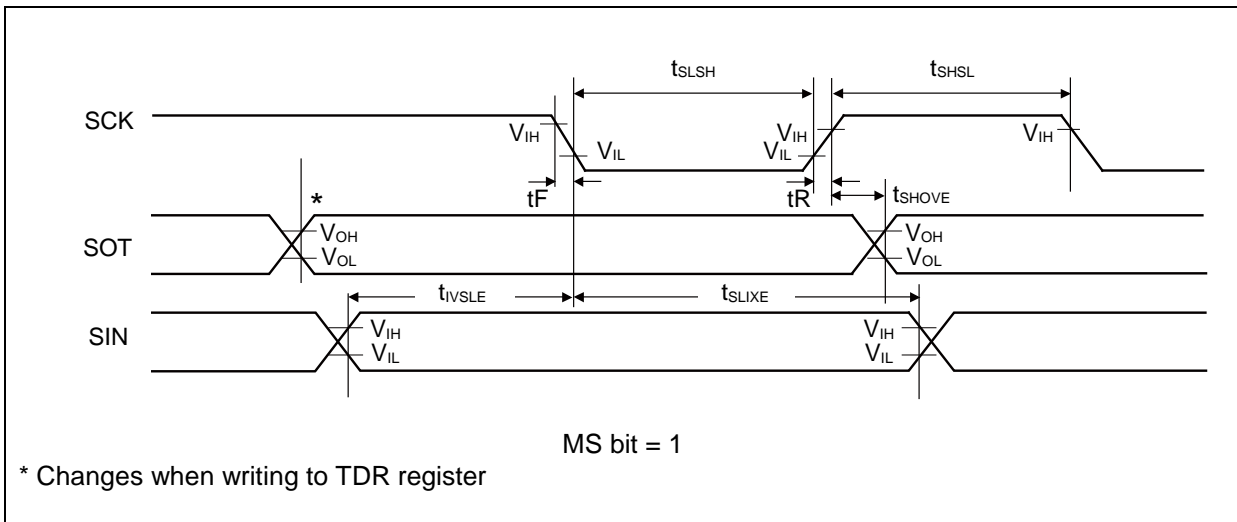
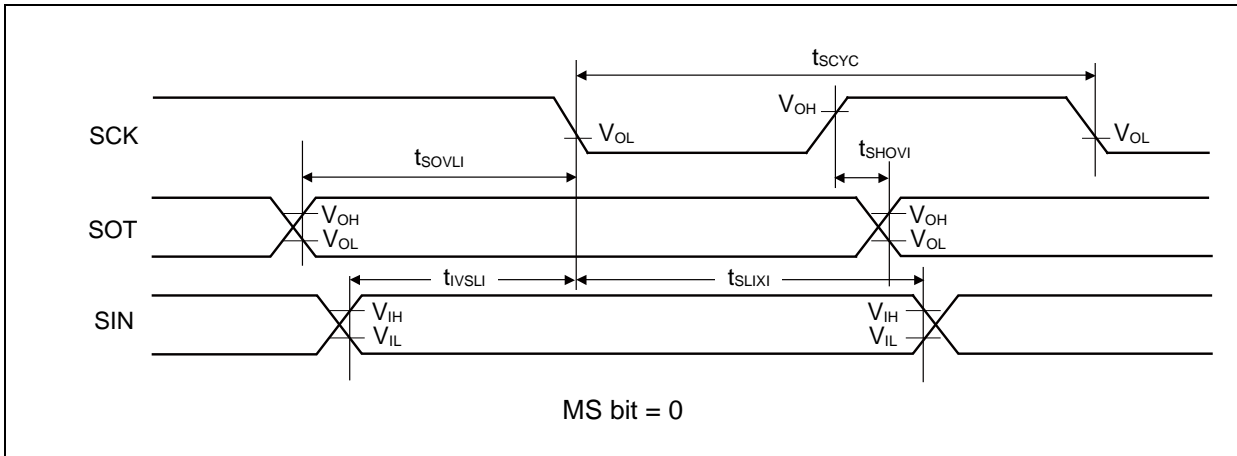

High-Speed Synchronous Serial (SPI = 1, SCINV = 1)

(V_{CC} = 2.7V to 5.5V, V_{SS} = 0V)

Parameter	Symbol	Pin Name	Conditions	V _{CC} < 4.5V		V _{CC} ≥ 4.5V		Unit
				Min	Max	Min	Max	
Baud rate	-	-	-	-	25	-	25	Mbps
Serial clock cycle time	t _{SCYC}	SCKx	Internal shift clock operation	4t _{CYCP}	-	4t _{CYCP}	-	ns
SCK↓→SOT delay time	t _{SLOVI}	SCKx, SOTx		- 10	+ 10	- 10	+ 10	ns
SIN→SCK↑ setup time	t _{IVSHI}	SCKx, SINx		14	-	12.5	-	ns
				12.5*				
SCK↑→SIN hold time	t _{SHIXI}	SCKx, SINx		5	-	5	-	ns
SOT→SCK↑ delay time	t _{SOVHI}	SCKx, SOTx		2t _{CYCP} - 10	-	2t _{CYCP} - 10	-	ns
Serial clock "L" pulse width	t _{SLSH}	SCKx		2t _{CYCP} - 5	-	2t _{CYCP} - 5	-	ns
Serial clock "H" pulse width	t _{SHSL}	SCKx	t _{CYCP} + 10	-	t _{CYCP} + 10	-	ns	
SCK↓→SOT delay time	t _{SLOVE}	SCKx, SOTx	External shift clock operation	-	15	-	15	ns
SIN→SCK↑ setup time	t _{IVSHE}	SCKx, SINx		5	-	5	-	ns
SCK↑→SIN hold time	t _{SHIXE}	SCKx, SINx		5	-	5	-	ns
SCK fall time	t _F	SCKx		-	5	-	5	ns
SCK rise time	t _R	SCKx		-	5	-	5	ns

Notes:

- The above characteristics apply to CLK synchronous mode.
- t_{CYCP} indicates the APB bus clock cycle time. For more information about the APB bus number to which the multi-function serial is connected, see "10. Block Diagram" in this data sheet.
- These characteristics only guarantee the following pins:
 No chip select: SIN4_0, SOT4_0, SCK4_0
 Chip select: SIN6_0, SOT6_0, SCK6_0, SCS60_0, SCS61_0, SCS62_0, SCS63_0
- When the external load capacitance C_L = 30 pF. (for *, when C_L = 10 pF)

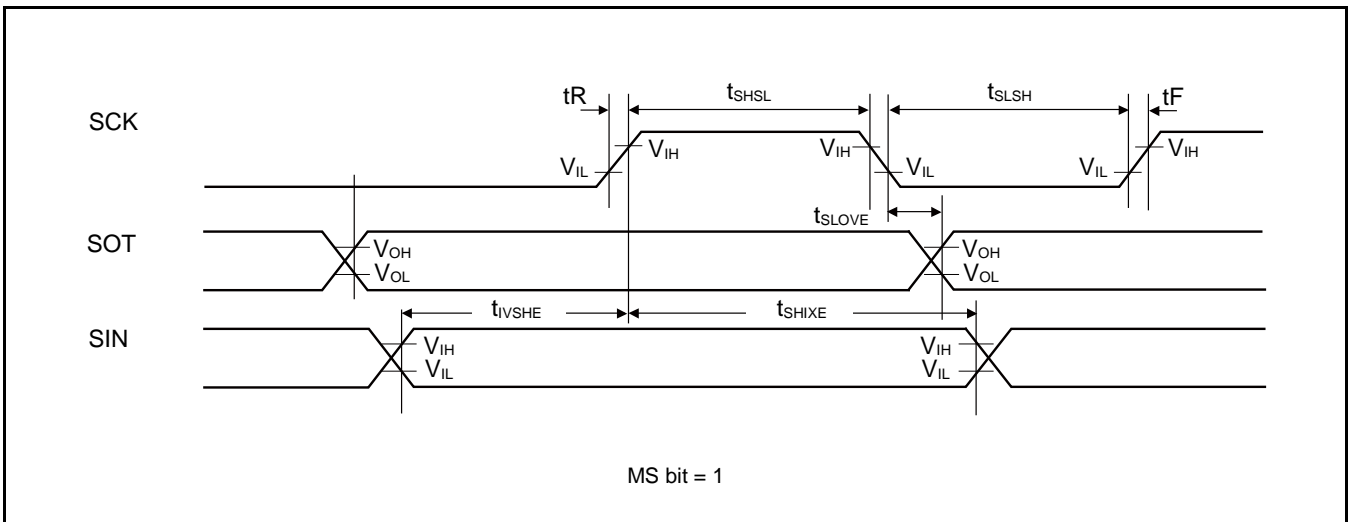
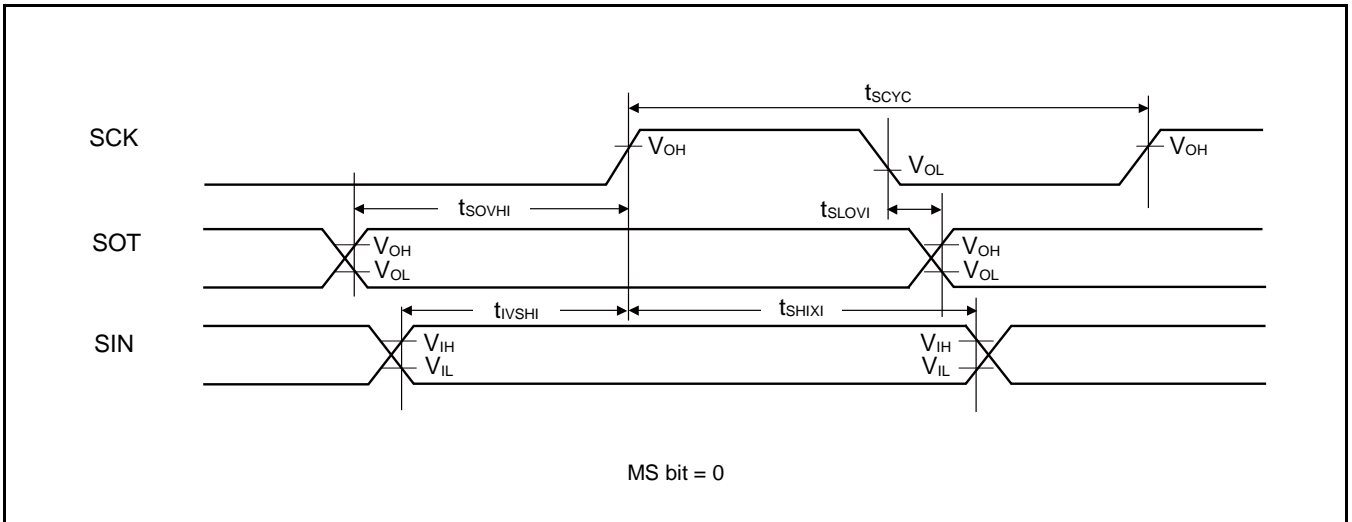

When Using High-Speed Synchronous Serial chip select (SPI = 1, SCINV = 0, MS = 0, CSLVL = 1)

(V_{CC} = 2.7V to 5.5V, V_{SS} = 0V)

Parameter	Symbol	Conditions	V _{CC} < 4.5V		V _{CC} ≥ 4.5V		Unit
			Min	Max	Min	Max	
SCS↓→SCK↓ setup time	t _{CSSI}	Internal shift clock operation	(*1)-20	(*1)+0	(*1)-20	(*1)+0	ns
SCK↑→SCS↑ hold time	t _{CShI}		(*2)+0	(*2)+20	(*2)+0	(*2)+20	ns
SCS deselect time	t _{CSDI}		(*3)-20 +5t _{CYCP}	(*3)+20 +5t _{CYCP}	(*3)-20 +5t _{CYCP}	(*3)+20 +5t _{CYCP}	ns
SCS↓→SCK↓ setup time	t _{CSSe}	External shift clock operation	3t _{CYCP} +15	-	3t _{CYCP} +15	-	ns
SCK↑→SCS↑ hold time	t _{CShE}		0	-	0	-	ns
SCS deselect time	t _{CSDe}		3t _{CYCP} +15	-	3t _{CYCP} +15	-	ns
SCS↓→SOT delay time	t _{DSE}		-	25	-	25	ns
SCS↑→SOT delay time	t _{DEE}		0	-	0	-	ns

(*1): CSSU bit value × serial chip select timing operating clock cycle [ns]

(*2): CSHD bit value × serial chip select timing operating clock cycle [ns]

(*3): CSDS bit value × serial chip select timing operating clock cycle [ns]

Notes:

- t_{CYCP} indicates the APB bus clock cycle time. For more information about the APB bus number to which the multi-function serial is connected, see "10. Block Diagram" in this data sheet.
- For more information about CSSU, CSHD, CSDS, and the serial chip select timing operating clock, see "FM4 Family Peripheral Manual Main Part (MN709-00001)."
- When the external load capacitance C_L = 30 pF.

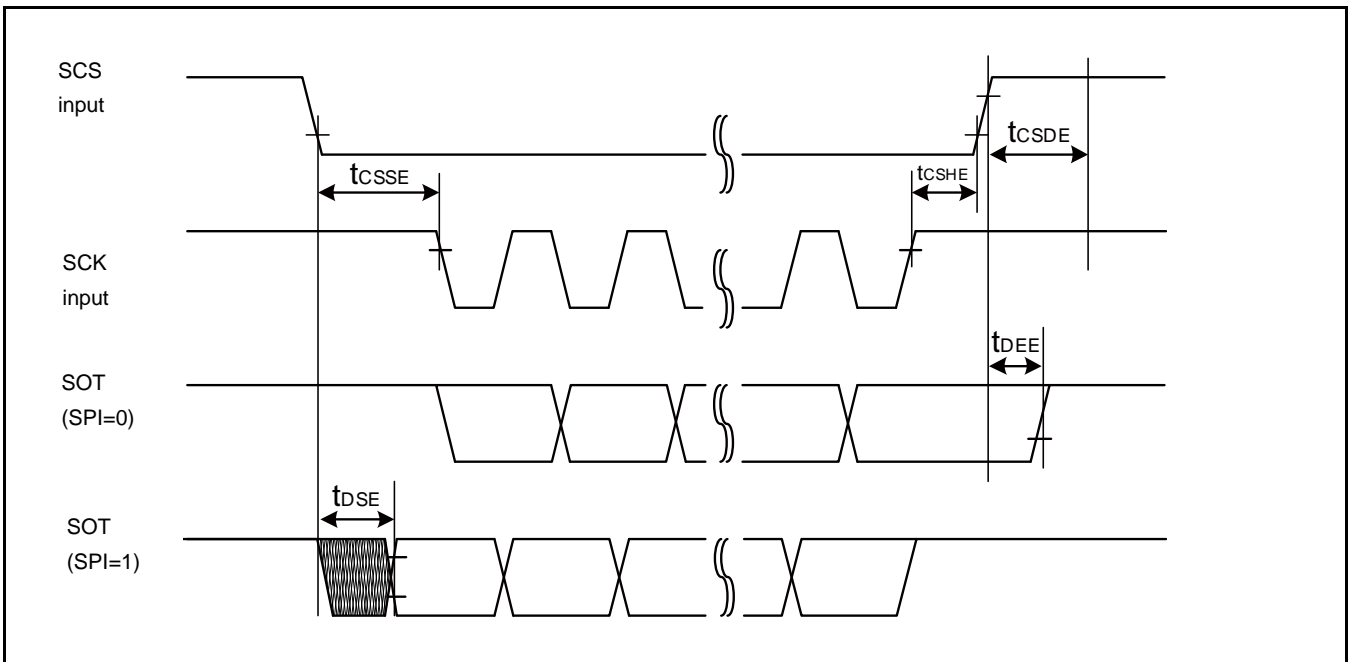
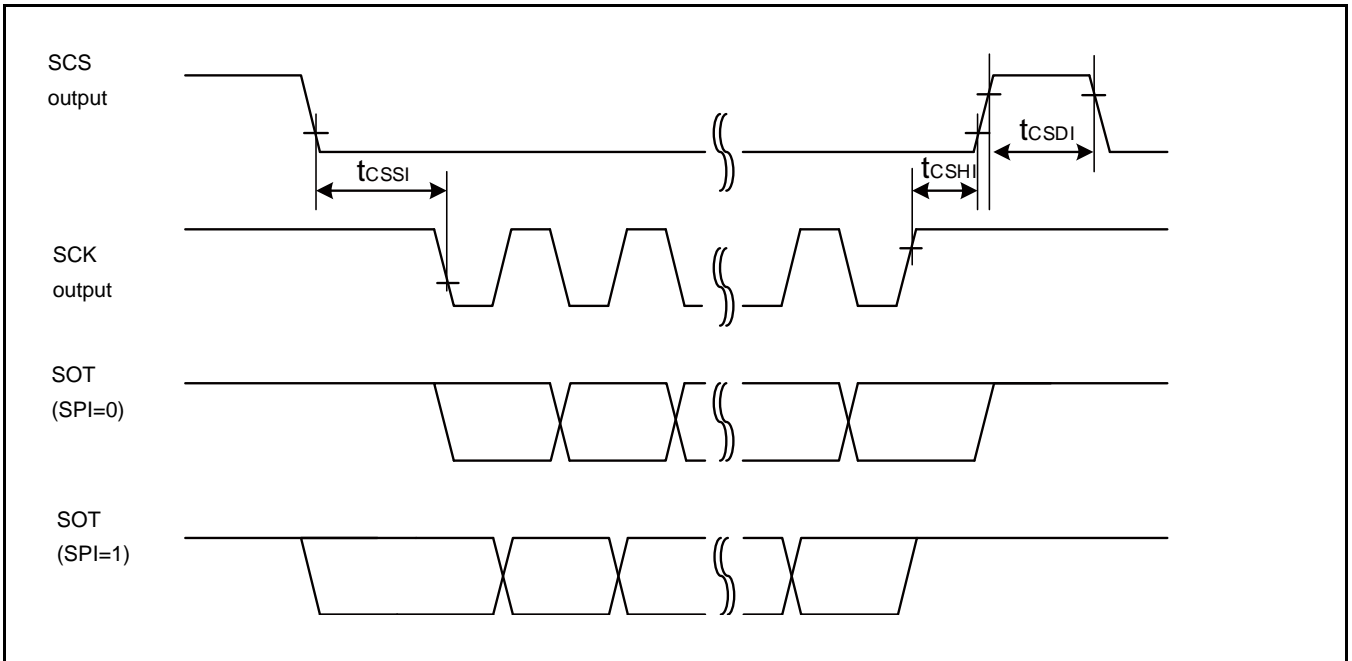

When Using High-Speed Synchronous Serial chip select (SPI = 1, SCINV = 1, MS = 0, CSLVL = 1)
(V_{CC} = 2.7V to 5.5V, V_{SS} = 0V)

Parameter	Symbol	Conditions	V _{CC} < 4.5V		V _{CC} ≥ 4.5V		Unit
			Min	Min	Min	Max	
SCS↓→SCK↓ setup time	t _{CSSI}	Internal shift clock operation	(*1)-20	(*1)+0	(*1)-20	(*1)+0	ns
SCK↑→SCS↑ hold time	t _{CShI}		(*2)+0	(*2)+20	(*2)+0	(*2)+20	ns
SCS deselect time	t _{CSDI}		(*3)-20 +5t _{CYCP}	(*3)+20 +5t _{CYCP}	(*3)-20 +5t _{CYCP}	(*3)+20 +5t _{CYCP}	ns
SCS↓→SCK↑ setup time	t _{CSSe}	External shift clock operation	3t _{CYCP} +15	-	3t _{CYCP} +15	-	ns
SCK↑→SCS↑ hold time	t _{CShE}		0	-	0	-	ns
SCS deselect time	t _{CSDe}		3t _{CYCP} +15	-	3t _{CYCP} +15	-	ns
SCS↓→SOT delay time	t _{DSE}		-	25	-	25	ns
SCS↑→SOT delay time	t _{DSE}		0	-	0	-	ns

(*1) : CSSU bit valuesserial chip select timing operating clock cycle [ns]

(*2) : CSHD bit valuesserial chip select timing operating clock cycle [ns]

(*3) : CSDS bit valuesserial chip select timing operating clock cycle [ns]

Notes:

- t_{CYCP} indicates the APB bus clock cycle time. For more information about the APB bus number to which the multi-function serial is connected, see "10. Block Diagram" in this data sheet.
- For more information about CSSU, CSHD, CSDS, and the serial chip select timing operating clock, see "FM4 Family Peripheral Manual Main Part (MN709-00001)."
- When the external load capacitance C_L = 30 pF.

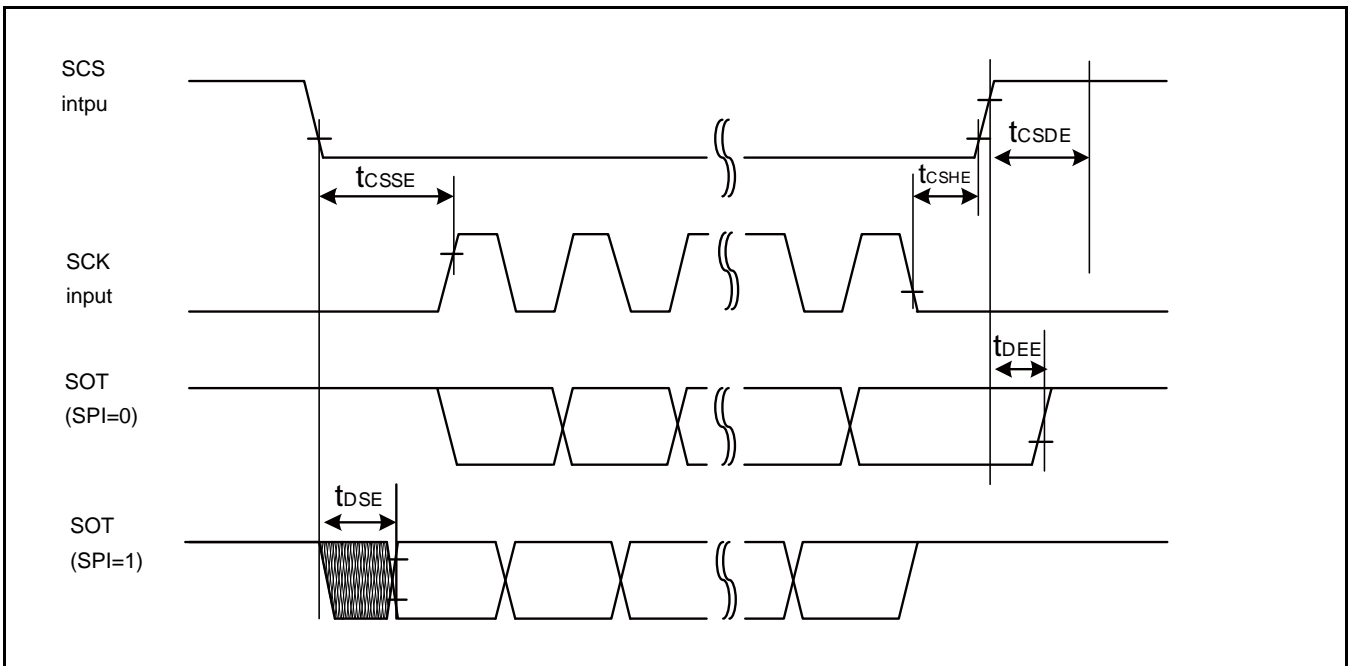
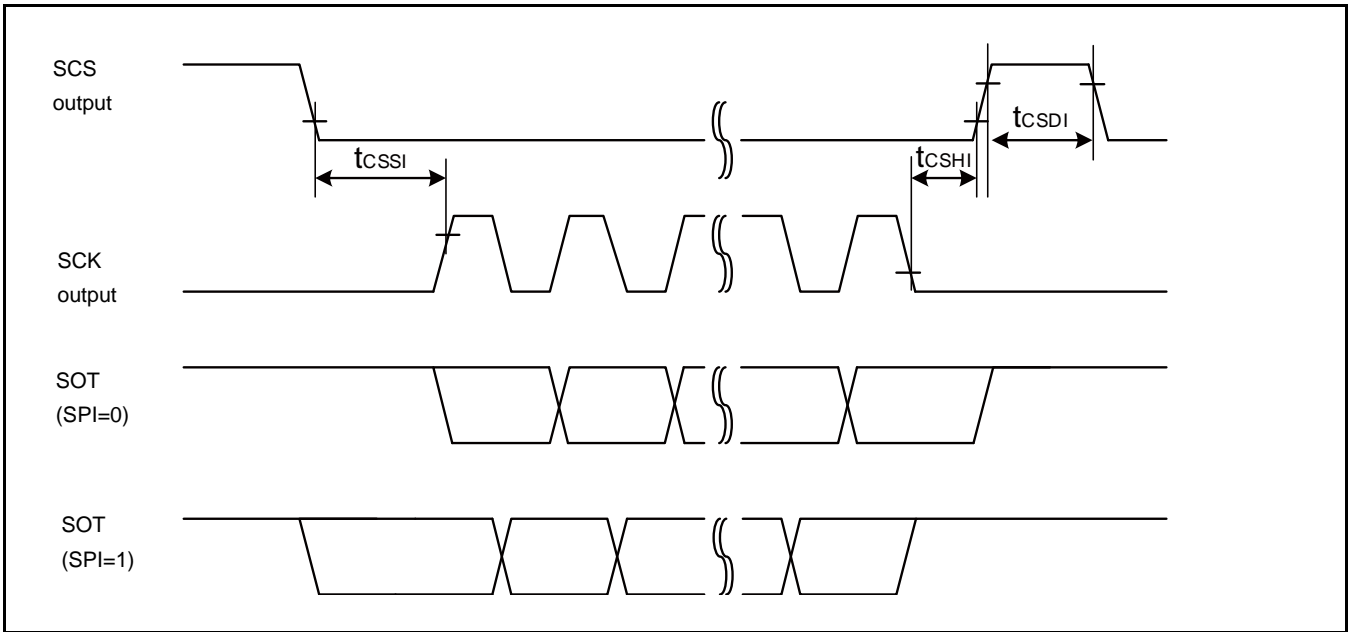

When Using High-Speed Synchronous Serial chip select (SPI = 1, SCINV = 0, MS = 0, CSLVL = 0)

(V_{CC} = 2.7V to 5.5V, V_{SS} = 0V)

Parameter	Symbol	Conditions	V _{CC} < 4.5V		V _{CC} ≥ 4.5V		Unit
			Min	Max	Min	Max	
SCS↑→SCK↓ setup time	t _{CSSI}	Internal shift clock operation	(*1)-20	(*1)+0	(*1)-20	(*1)+0	ns
SCK↑→SCS↓ hold time	t _{CShI}		(*2)+0	(*2)+20	(*2)+0	(*2)+20	ns
SCS deselect time	t _{CSDI}		(*3)-20 +5t _{CYCP}	(*3)+20 +5t _{CYCP}	(*3)-20 +5t _{CYCP}	(*3)+20 +5t _{CYCP}	ns
SCS↑→SCK↓ setup time	t _{CSSE}	External shift clock operation	3t _{CYCP} +15	-	3t _{CYCP} +15	-	ns
SCK↑→SCS↓ hold time	t _{CShE}		0	-	0	-	ns
SCS deselect time	t _{CSDE}		3t _{CYCP} +15	-	3t _{CYCP} +15	-	ns
SCS↑→SOT delay time	t _{DSE}		-	25	-	25	ns
SCS↓→SOT delay time	t _{DEE}		0	-	0	-	ns

(*1) : CSSU bit value × serial chip select timing operating clock cycle [ns]

(*2) : CSHD bit value × serial chip select timing operating clock cycle [ns]

(*3) : CSDS bit value × serial chip select timing operating clock cycle [ns]

Notes:

- t_{CYCP} indicates the APB bus clock cycle time. For more information about the APB bus number to which the multi-function serial is connected, see "10. Block Diagram" in this data sheet.
- For more information about CSSU, CSHD, CSDS, and the serial chip select timing operating clock, see "FM4 Family Peripheral Manual Main Part (MN709-00001)."
- When the external load capacitance C_L = 30 pF.

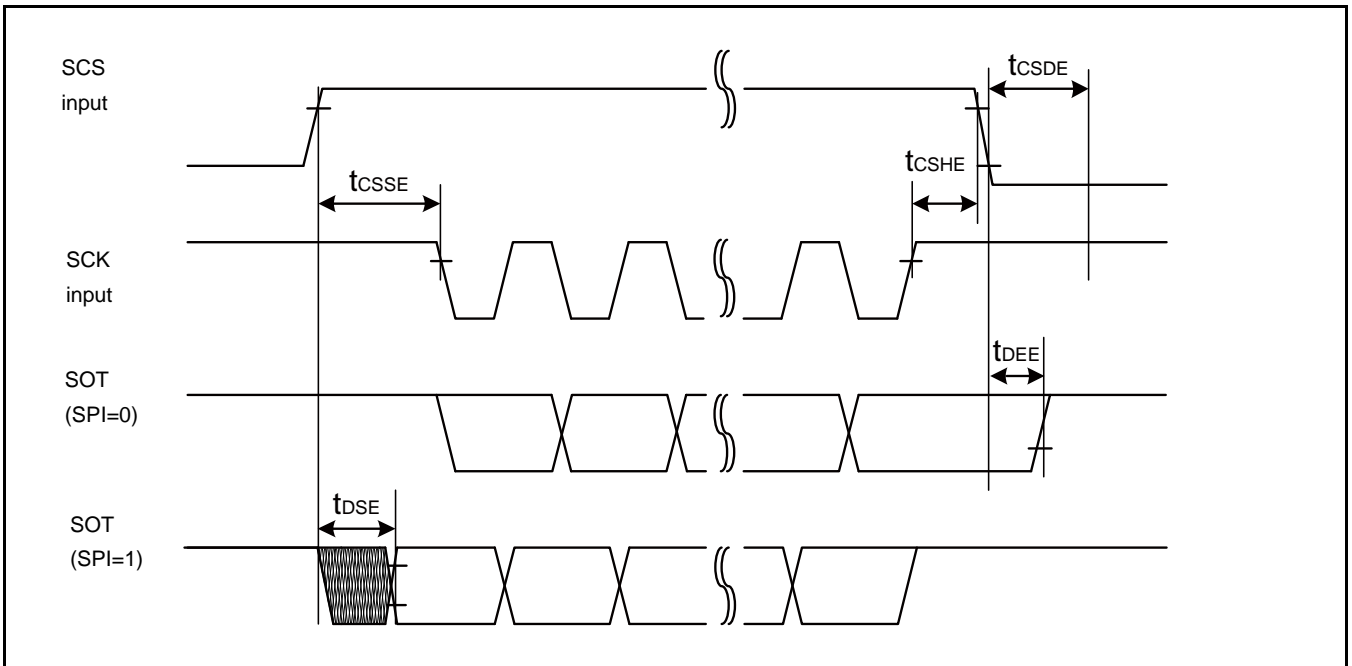
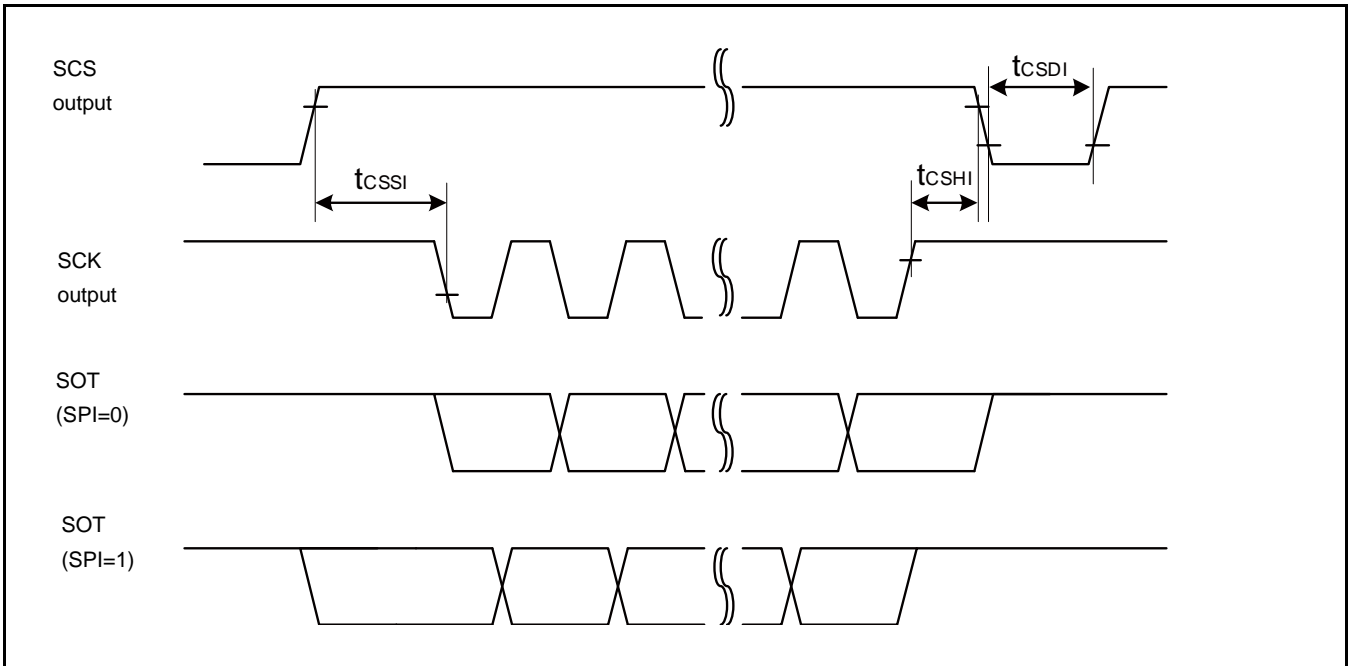

When Using High-Speed Synchronous Serial chip select (SPI = 1, SCINV = 1, MS = 0, CSLVL = 0)

(V_{CC} = 2.7V to 5.5V, V_{SS} = 0V)

Parameter	Symbol	Conditions	V _{CC} < 4.5V		V _{CC} ≥ 4.5V		Unit
			Min	Max	Min	Max	
SCS↓→SCK↓ setup time	t _{CSSI}	Internal shift clock operation	(*1)-20	(*1)+0	(*1)-20	(*1)+0	ns
SCK↑→SCS↓ hold time	t _{CSHI}		(*2)+0	(*2)+20	(*2)+0	(*2)+20	ns
SCS deselect time	t _{CSDI}		(*3)-20 +5t _{CYCP}	(*3)+20 +5t _{CYCP}	(*3)-20 +5t _{CYCP}	(*3)+20 +5t _{CYCP}	ns
SCS↑→SCK↑ setup time	t _{CSSE}	External shift clock operation	3t _{CYCP} +15	-	3t _{CYCP} +15	-	ns
SCK↓→SCS↓ hold time	t _{CSHE}		0	-	0	-	ns
SCS deselect time	t _{CSDE}		3t _{CYCP} +15	-	3t _{CYCP} +15	-	ns
SCS↑→SOT delay time	t _{DSE}		-	40	-	40	ns
SCS↓→SOT delay time	t _{DEE}		0	-	0	-	ns

(*1) : CSSU bit valuesserial chip select timing operating clock cycle [ns]

(*2) : CSHD bit valuesserial chip select timing operating clock cycle [ns]

(*3) : CSDS bit valuesserial chip select timing operating clock cycle [ns]

Notes:

- t_{CYCP} indicates the APB bus clock cycle time. For more information about the APB bus number to which the multi-function serial is connected, see "10. Block Diagram" in this data sheet.
- For more information about CSSU, CSHD, CSDS, and the serial chip select timing operating clock, see "FM4 Family Peripheral Manual Main Part (MN709-00001)."
- When the external load capacitance C_L = 30 pF.

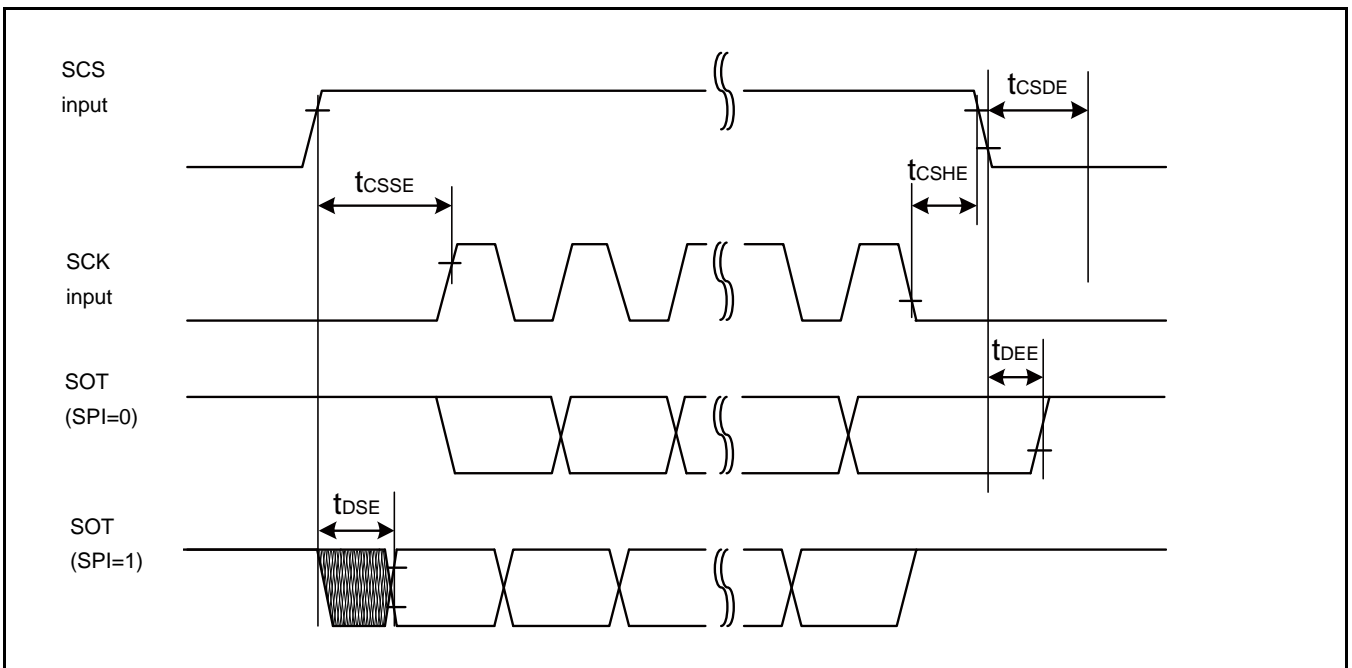
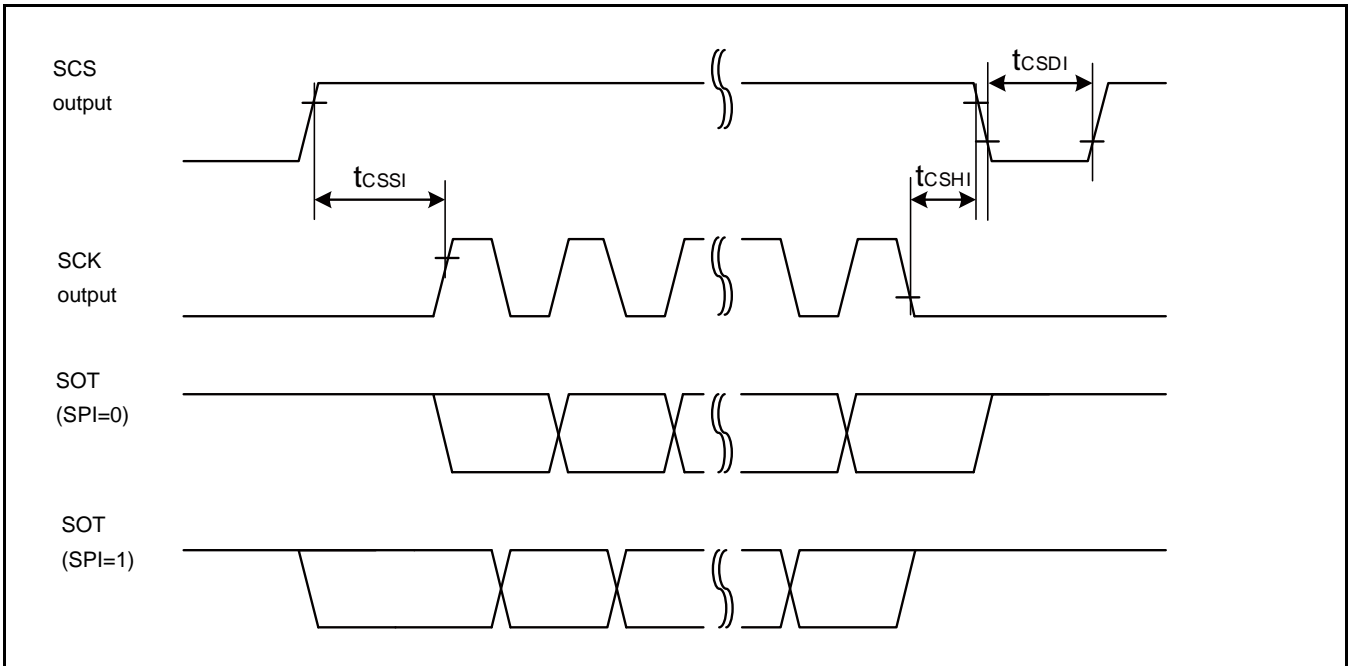

External clock (EXT = 1): When in Asynchronous Mode Only

($V_{CC} = 2.7V$ to $5.5V$, $V_{SS} = 0V$)

Parameter	Symbol	Condition	Value		Unit	Remarks
			Min	Max		
Serial clock "L" pulse width	t_{SLSH}	$C_L = 30\text{ pF}$	$t_{CYCP} + 10$	-	ns	
Serial clock "H" pulse width	t_{SHSL}		$t_{CYCP} + 10$	-	ns	
SCK fall time	t_F		-	5	ns	
SCK rise time	t_R		-	5	ns	

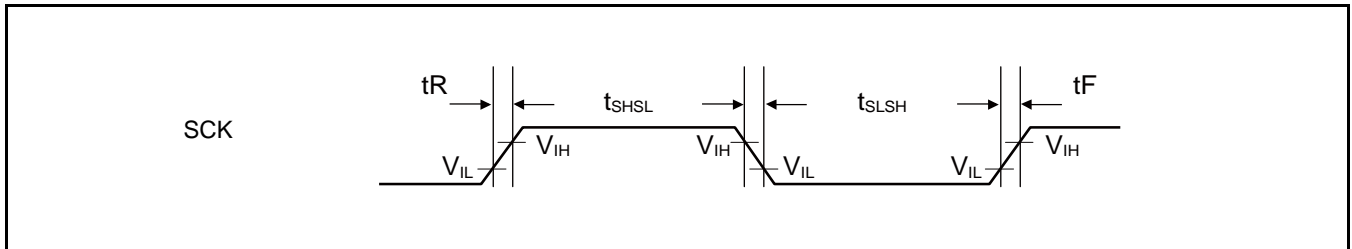

14.4.13 External Input Timing

(V_{CC} = 2.7V to 5.5V, V_{SS} = 0V)

Parameter	Symbol	Pin Name	Conditions	Value		Unit	Remarks
				Min	Max		
Input pulse width	t _{INH} , t _{INL}	ADTGx	-	2t _{CYCP} ^{*1}	-	ns	A/D converter trigger input
		FRCKx					Free-run timer input clock
		ICxx					Input capture
		DTTIXX	-	2t _{CYCP} ^{*1}	-	ns	Waveform generator
		INT00 to INT31, NMIX	-	2t _{CYCP} + 100 ^{*1}	-	ns	External interrupt, NMI
				500 ^{*2}	-	ns	
WKUPx	-	500 ^{*3}	-	ns	Deep standby wake up		

- 1 : t_{CYCP} indicates the APB bus clock cycle time except stop when in Stop mode, in timer mode. For more information about the APB bus number to which the A/D converter, multi-function timer, and external interrupt are connected, see "10. Block Diagram" in this data sheet.
- 2 : When in Stop mode, in timer mode
- 3 : When in Deep standby RTC mode, in Deep standby Stop mode

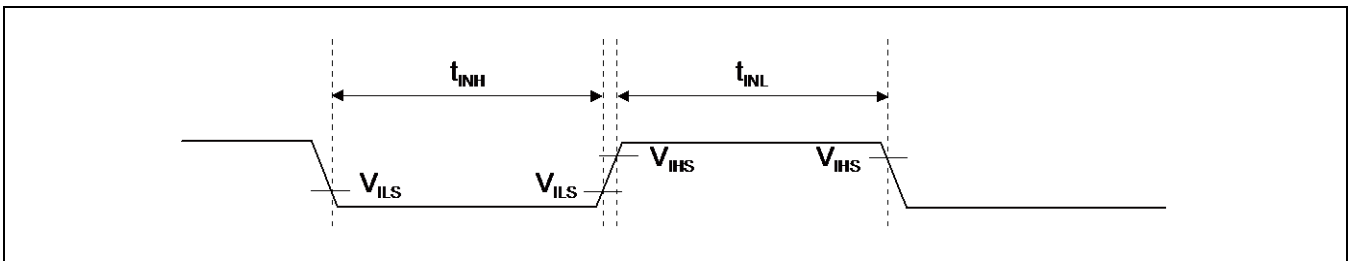

14.4.14 Quadrature Position/Revolution Counter Timing

($V_{CC} = AV_{CC} = 2.7V$ to $5.5V$, $V_{SS} = AV_{SS} = 0V$, $T_a = -40^{\circ}C$ to $+105^{\circ}C$)

Parameter	Symbol	Conditions	Value		Unit
			Min	Max	
AIN pin "H" width	t_{AHL}	-	$2t_{CYCP}^*$	-	ns
AIN pin "L" width	t_{ALL}	-			
BIN pin "H" width	t_{BHL}	-			
BIN pin "L" width	t_{BLL}	-			
BIN rise time from AIN pin "H" level	t_{AUBU}	PC_Mode2 or PC_Mode3			
AIN fall time from BIN pin "H" level	t_{BUAD}	PC_Mode2 or PC_Mode3			
BIN fall time from AIN pin "L" level	t_{ADBD}	PC_Mode2 or PC_Mode3			
AIN rise time from BIN pin "L" level	t_{BDAU}	PC_Mode2 or PC_Mode3			
AIN rise time from BIN pin "H" level	t_{BUAU}	PC_Mode2 or PC_Mode3			
BIN fall time from AIN pin "H" level	t_{AUBD}	PC_Mode2 or PC_Mode3			
AIN fall time from BIN pin "L" level	t_{BDAD}	PC_Mode2 or PC_Mode3			
BIN rise time from AIN pin "L" level	t_{ADBU}	PC_Mode2 or PC_Mode3			
ZIN pin "H" width	t_{ZHL}	QCR: CGSC = 0			
ZIN pin "L" width	t_{ZLL}	QCR: CGSC = 0			
AIN/BIN rise and fall time from determined ZIN level	t_{ZABE}	QCR: CGSC = 1			
Determined ZIN level from AIN/BIN rise and fall time	t_{ABEZ}	QCR: CGSC = 1			

* : t_{CYCP} indicates the APB bus clock cycle time except when in Stop mode, in timer mode. For more information about the APB bus number to which the quadrature position/revolution counter is connected, see "10. Block Diagram" in this data sheet.

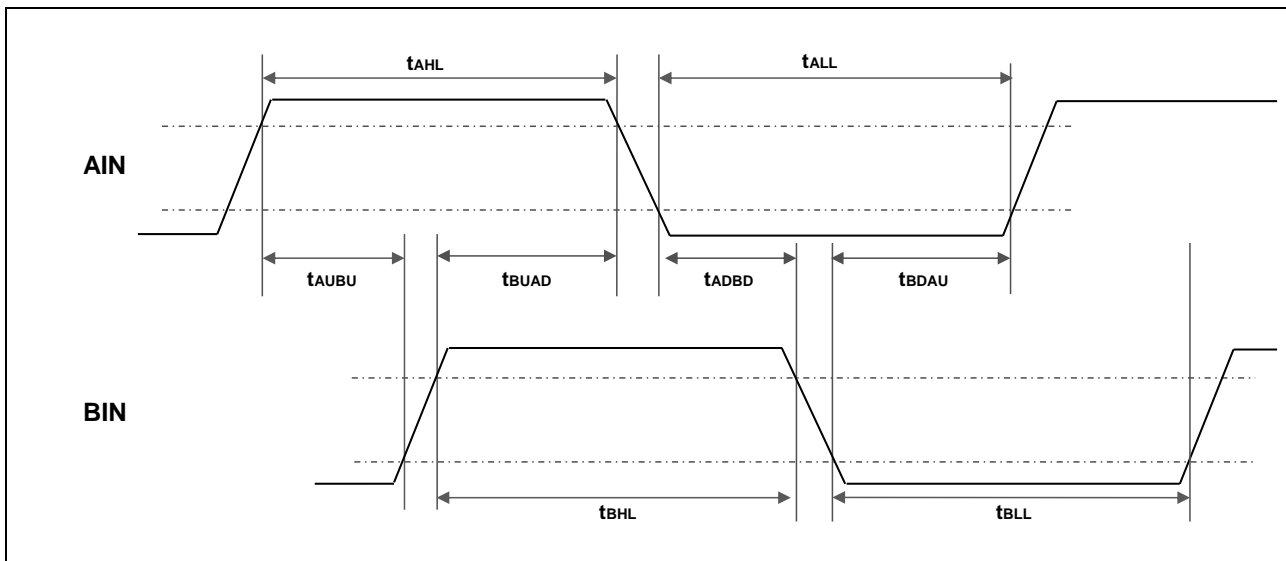

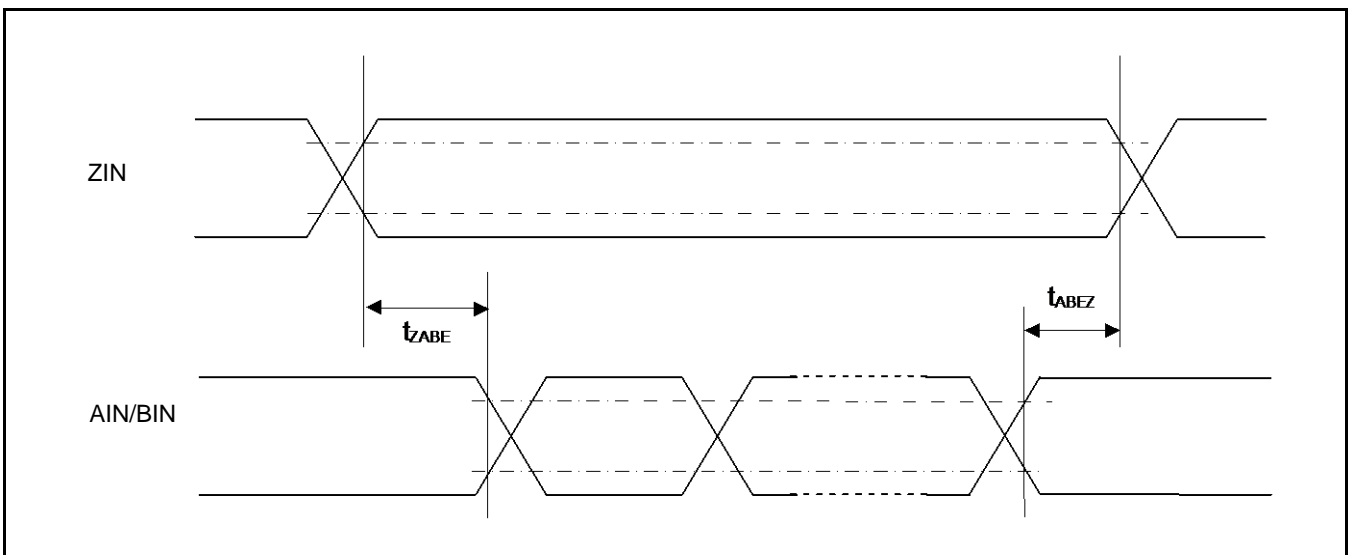
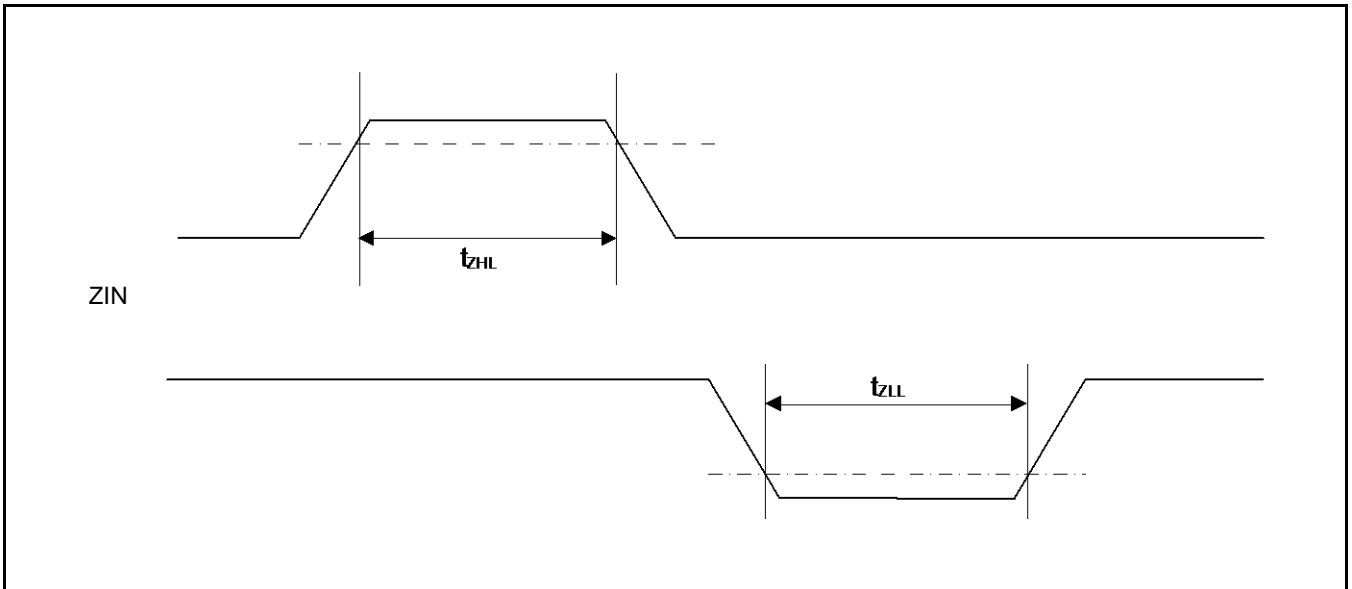
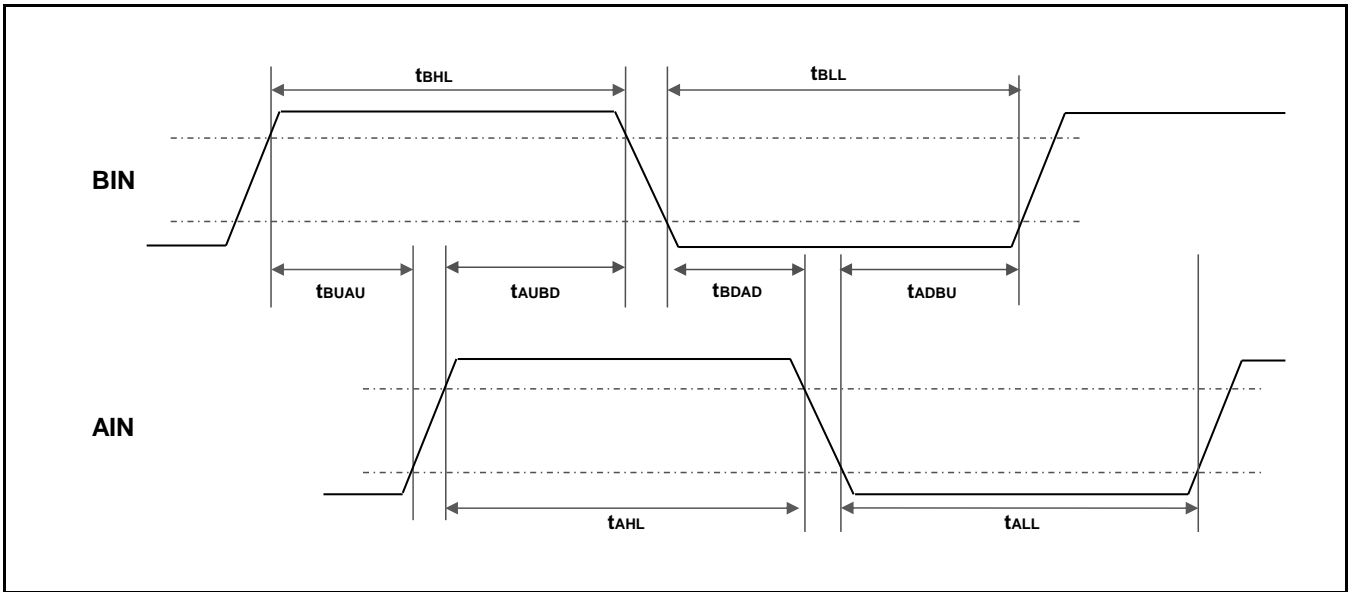

14.4.15 I²C Timing

Standard-mode, Fast-mode

(V_{CC} = 2.7V to 5.5V, V_{SS} = 0V)

Parameter	Symbol	Conditions	Standard-mode		Fast-mode		Unit	Remarks
			Min	Max	Min	Max		
SCL clock frequency	F _{SCL}	C _L = 30 pF, R = (V _p /I _{OL}) ^{*1}	0	100	0	400	kHz	
(Repeated) START condition hold time SDA ↓ → SCL ↓	t _{HDSTA}		4.0	-	0.6	-	μs	
SCL clock "L" width	t _{LOW}		4.7	-	1.3	-	μs	
SCL clock "H" width	t _{HIGH}		4.0	-	0.6	-	μs	
(Repeated) START condition setup time SCL ↑ → SDA ↓	t _{SUSTA}		4.7	-	0.6	-	μs	
Data hold time SCL ↓ → SDA ↓ ↑	t _{HDDAT}		0	3.45 ^{*2}	0	0.9 ^{*3}	μs	
Data setup time SDA ↓ ↑ → SCL ↑	t _{SUDAT}		250	-	100	-	ns	
Stop condition setup time SCL ↑ → SDA ↑	t _{SUSTO}		4.0	-	0.6	-	μs	
Bus free time between "Stop condition" and "START condition"	t _{BUF}		4.7	-	1.3	-	μs	
Noise filter	t _{SP}	2 MHz ≤ t _{CYCP} < 40 MHz	2 t _{CYCP} ^{*4}	-	2 t _{CYCP} ^{*4}	-	ns	*5
		40 MHz ≤ t _{CYCP} < 60 MHz	4 t _{CYCP} ^{*4}	-	4 t _{CYCP} ^{*4}	-	ns	
		60 MHz ≤ t _{CYCP} < 80 MHz	6 t _{CYCP} ^{*4}	-	6 t _{CYCP} ^{*4}	-	ns	
		80 MHz ≤ t _{CYCP} ≤ 100 MHz	8 t _{CYCP} ^{*4}	-	8 t _{CYCP} ^{*4}	-	ns	

1 : R and C_L represent the pull-up resistance and load capacitance of the SCL and SDA lines, respectively. V_p indicates the power supply voltage of the pull-up resistance and I_{OL} indicates V_{OL} guaranteed current.

2 : The maximum t_{HDDT} must not extend beyond the low period (t_{LOW}) of the device's SCL signal.

3 : Fast-mode I²C bus device can be used on a Standard-mode I²C bus system as long as the device satisfies the requirement of "t_{SUDAT} ≥ 250 ns."

4 : t_{CYCP} is the APB bus clock cycle time. For more information about the APB bus number to which the I²C is connected, see "10.Block Diagram" in this data sheet.

When using Standard-mode, the peripheral bus clock must be set more than 2 MHz.

When using Fast-mode, the peripheral bus clock must be set more than 8 MHz.

5 : The noise filter time can be changed by register settings. Change the number of the noise filter steps according to the APB bus clock frequency.

Fast Mode Plus (Fm+)

(V_{CC} = 2.7V to 5.5V, V_{SS} = 0V)

Parameter	Symbol	Conditions	Fast Mode Plus (Fm+)*6		Unit	Remarks
			Min	Max		
SCL clock frequency	F _{SCL}	C _L = 30 pF, R = (V _p /I _{OL})*1	0	1000	kHz	
(Repeated) START condition hold time SDA ↓ → SCL ↓	t _{HDSTA}		0.26	-	μs	
SCL clock "L" width	t _{LOW}		0.5	-	μs	
SCL clock "H" width	t _{HIGH}		0.26	-	μs	
SCL clock frequency	t _{SUSTA}		0.26	-	μs	
(Repeated) START condition hold time SDA ↓ → SCL ↓	t _{HDDAT}		0	0.45*2, *3	μs	
Data setup time SDA ↓ ↑ → SCL ↑	t _{SUDAT}		50	-	ns	
Stop condition setup time SCL ↑ → SDA ↑	t _{SUSTO}		0.26	-	μs	
Bus free time between "Stop condition" and "START condition"	t _{BUF}		0.5	-	μs	
Noise filter	t _{SP}		60 MHz ≤ t _{CYCP} < 80 MHz	6 t _{CYCP} *4	-	ns
		80 MHz ≤ t _{CYCP} ≤ 100 MHz	8 t _{CYCP} *4	-	ns	

- 1 : R and C_L represent the pull-up resistance and load capacitance of the SCL and SDA lines, respectively. V_p indicates the power supply voltage of the pull-up resistance and I_{OL} indicates V_{OL} guaranteed current.
- 2 : The maximum t_{HDDT} must not extend beyond the low period (t_{LOW}) of the device's SCL signal.
- 3 : The Fast mode I²C bus device can be used on a Standard-mode I²C bus system as long as the device satisfies the requirement of "t_{SUDAT} ≥ 250 ns."
- 4 : t_{CYCP} is the APB bus clock cycle time. For more information about the APB bus number to which the I²C is connected, see "10.Block Diagram" in this data sheet.
To use fast mode plus (Fm+), set the peripheral bus clock at 64 MHz or more.
- 5 : The noise filter time can be changed by register settings. Change the number of the noise filter steps according to the APB bus clock frequency.
- 6 : When using fast mode plus (Fm+), set the I/O pin to the mode corresponding to I²C Fm+ in the EPFR register.
See "Chapter12: I/O PORT" in "FM4 Family Peripheral Manual Main Part (MN709-00001)" for the details.

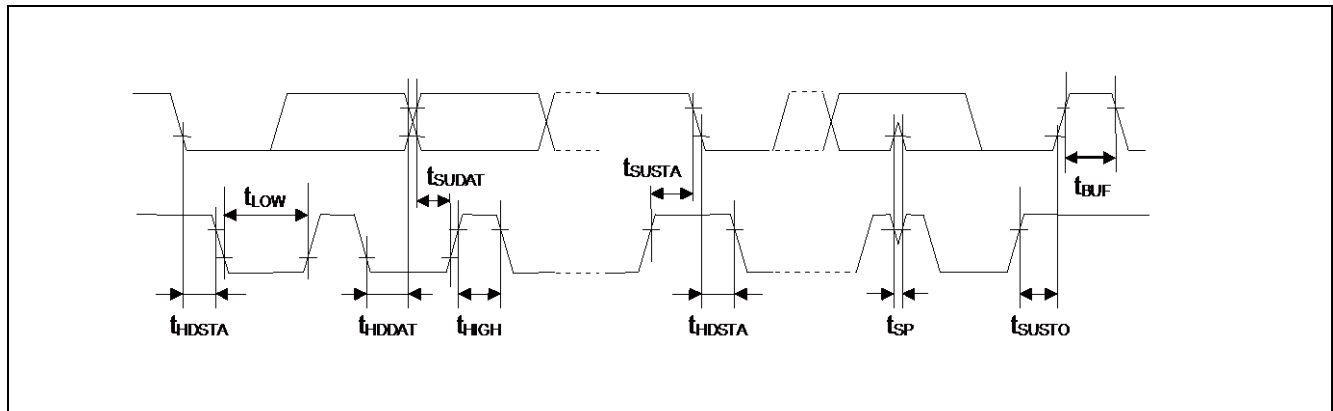

14.4.16 SD Card Interface Timing

Default-Speed Mode

- Clock CLK (All values are referenced to V_{IH} and V_{IL} transition points)

($V_{CC} = 2.7V$ to $3.6V$, $V_{SS} = 0V$)

Parameter	Symbol	Pin Name	Conditions	Value		Remarks
				Min	Max	
Clock frequency Data Transfer Mode	f_{PP}	S_CLK	$C_{CARD} \leq 10$ pF (1card)	0	25	MHz
Clock frequency Identification Mode	f_{OD}	S_CLK		0/100	400	kHz
Clock low time	t_{WL}	S_CLK		10	-	ns
Clock high time	t_{WH}	S_CLK		10	-	ns
Clock rise time	t_{TLH}	S_CLK		-	10	ns
Clock fall time	t_{THL}	S_CLK		-	10	ns

* 0 Hz means to stop the clock. The given minimum frequency range is for cases where a continuous clock is required.

- Card Inputs CMD, DAT (referenced to Clock CLK)

Parameter	Symbol	Pin Name	Conditions	Value		Remarks
				Min	Max	
Input set-up time	t_{ISU}	S_CMD, S_DATA3: 0	$C_{CARD} \leq 10$ pF (1card)	5	-	ns
Input hold time	t_{IH}	S_CMD, S_DATA3: 0		5	-	ns

- Card Outputs CMD, DAT (referenced to Clock CLK)

Parameter	Symbol	Pin Name	Conditions	Value		Remarks
				Min	Max	
Output Delay time during Data Transfer Mode	t_{ODLY}	S_CMD, S_DATA3: 0	$C_{CARD} \leq 40$ pF (1card)	0	14	ns
Output Delay time during Identification Mode	t_{ODLY}	S_CMD, S_DATA3: 0		0	50	ns

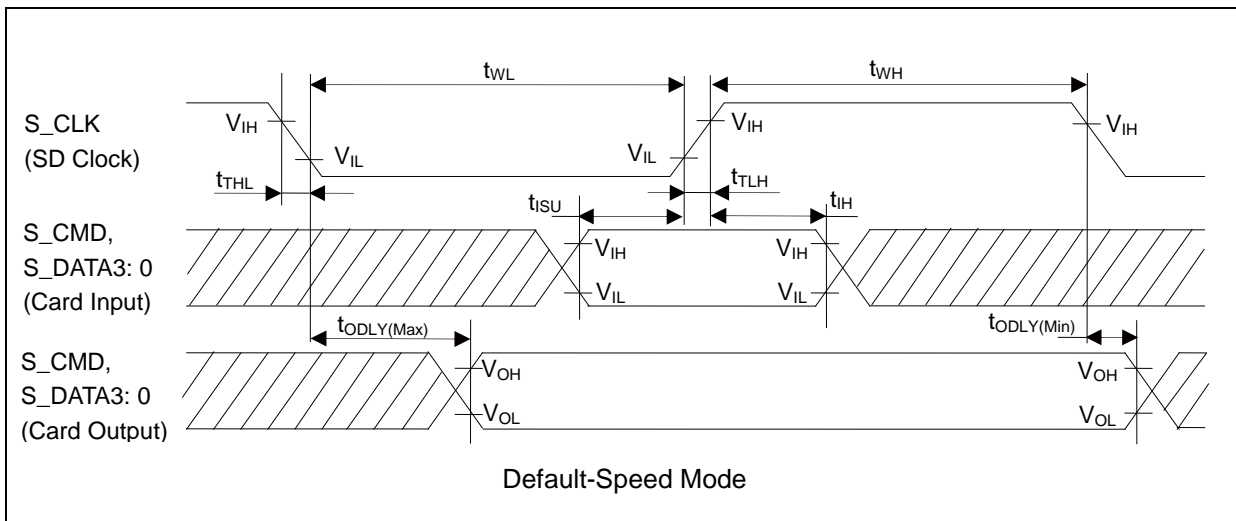

Notes:

- The Card Input corresponds to the Host Output and the Card Output corresponds to the Host Input because this model is the Host.
- For more information about clock frequency (f_{PP}), see "Chapter 15: SD card Interface" in "FM4 Family Peripheral Manual Main Part (MN709-00001)."

High-Speed Mode

■ Clock CLK (All values are referred to V_{IH} and V_{IL})

($V_{CC} = 2.7V$ to $3.6V$, $V_{SS} = 0V$)

Parameter	Symbol	Pin Name	Conditions	Value		Remarks
				Min	Max	
Clock frequency Data Transfer Mode	f_{PP}	S_CLK	$C_{CARD} \leq 10$ pF (1card)	0	50	MHz
Clock low time	t_{WL}	S_CLK		7	-	ns
Clock high time	t_{WH}	S_CLK		7	-	ns
Clock rise time	t_{TLH}	S_CLK		-	3	ns
Clock fall time	t_{THL}	S_CLK		-	3	ns

■ Card Inputs CMD, DAT (referenced to Clock CLK)

Parameter	Symbol	Pin Name	Conditions	Value		Remarks
				Min	Max	
Input set-up time	t_{ISU}	S_CMD, S_DATA3: 0	$C_{CARD} \leq 10$ pF (1card)	6	-	ns
Input hold time	t_{IH}	S_CMD, S_DATA3: 0		2	-	ns

■ Card Outputs CMD, DAT (referenced to Clock CLK)

Parameter	Symbol	Pin Name	Conditions	Value		Remarks
				Min	Max	
Output delay time during data transfer mode	t_{ODLY}	S_CMD, S_DATA3: 0	$C_L \leq 40$ pF (1card)	0	14	ns
Output hold time	t_{OH}	S_CMD, S_DATA3: 0	$C_L \geq 15$ pF (1card)	2.5	-	ns
Total system capacitance for each line*	C_L	-	1card	-	40	pF

* : In order to satisfy severe timing, host shall drive only one card.

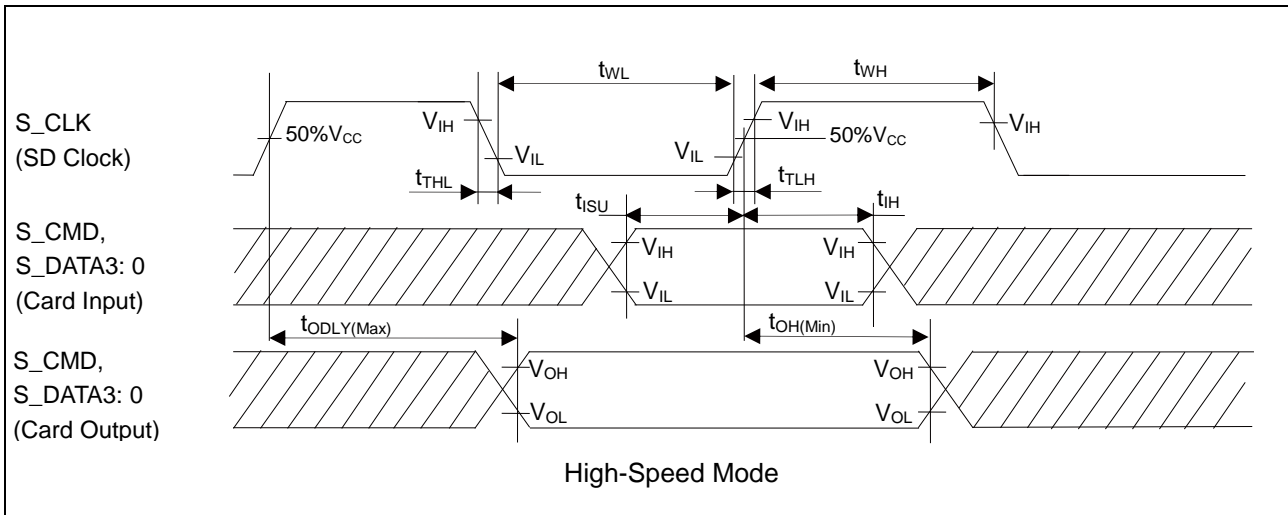

Notes:

- The Card Input corresponds to the Host Output and the Card Output corresponds to the Host Input because this model is the Host.
- For more information about clock frequency (f_{PP}), see "Chapter 15: SD card Interface" in "FM4 Family Peripheral Manual Main Part (MN709-00001)."

14.4.17 ETM/ HTM Timing

($V_{CC} = 2.7V$ to $5.5V$, $V_{SS} = 0V$)

Parameter	Symbol	Pin Name	Conditions	Value		Unit	Remarks
				Min	Max		
Data hold	t_{ETMH}	TRACECLK, TRACED[15: 0]	$V_{CC} \geq 4.5V$	2	9	ns	
			$V_{CC} < 4.5V$	2	15		
TRACECLK frequency	$1/t_{TRACE}$	TRACECLK	$V_{CC} \geq 4.5V$		50	MHz	
			$V_{CC} < 4.5V$		32		
TRACECLK clock cycle	t_{TRACE}	TRACECLK	$V_{CC} \geq 4.5V$	20	-	ns	
			$V_{CC} < 4.5V$	31.25	-		

Note:

- When the external load capacitance $C_L = 30$ pF.

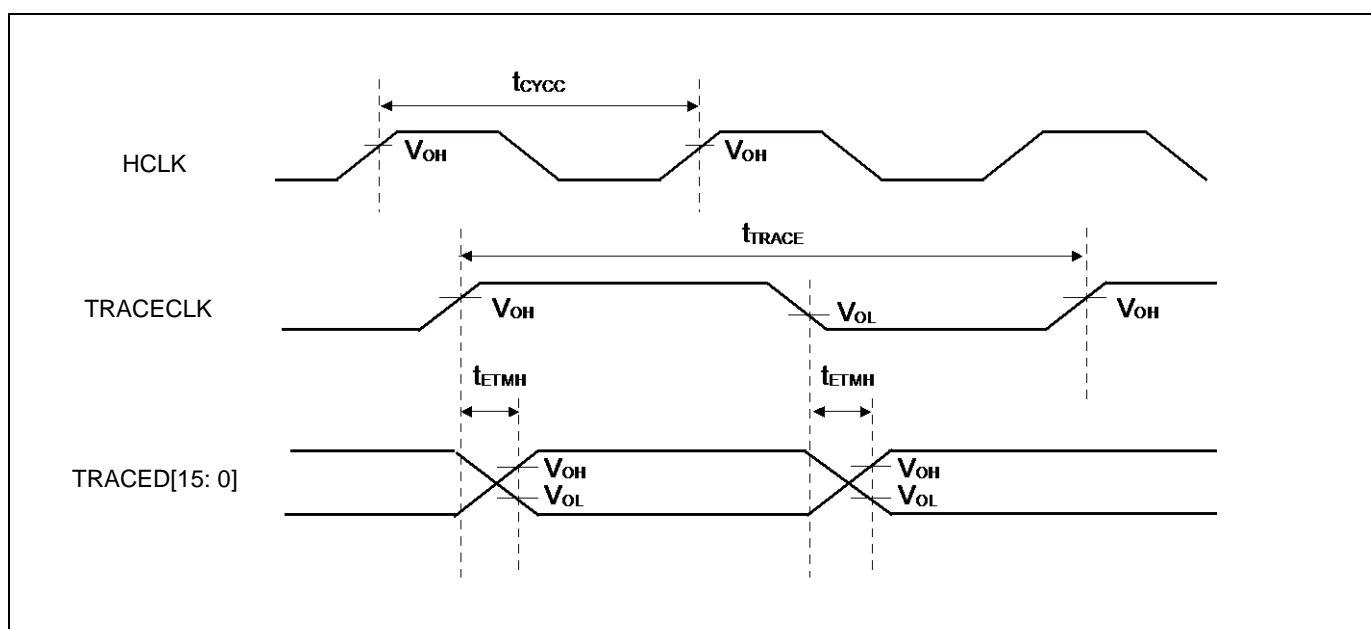

14.4.18 JTAG Timing

($V_{CC} = 2.7V$ to $5.5V$, $V_{SS} = 0V$)

Parameter	Symbol	Pin Name	Conditions	Value		Unit	Remarks
				Min	Max		
TMS, TDI setup time	t_{JTAGS}	TCK, TMS, TDI	$V_{CC} \geq 4.5V$	15	-	ns	
			$V_{CC} < 4.5V$				
TMS, TDI hold time	t_{JTAGH}	TCK, TMS, TDI	$V_{CC} \geq 4.5V$	15	-	ns	
			$V_{CC} < 4.5V$				
TDO delay time	t_{JTAGD}	TCK, TDO	$V_{CC} \geq 4.5V$	-	25	ns	
			$V_{CC} < 4.5V$	-	45		

Note:

- When the external load capacitance $C_L = 30$ pF.

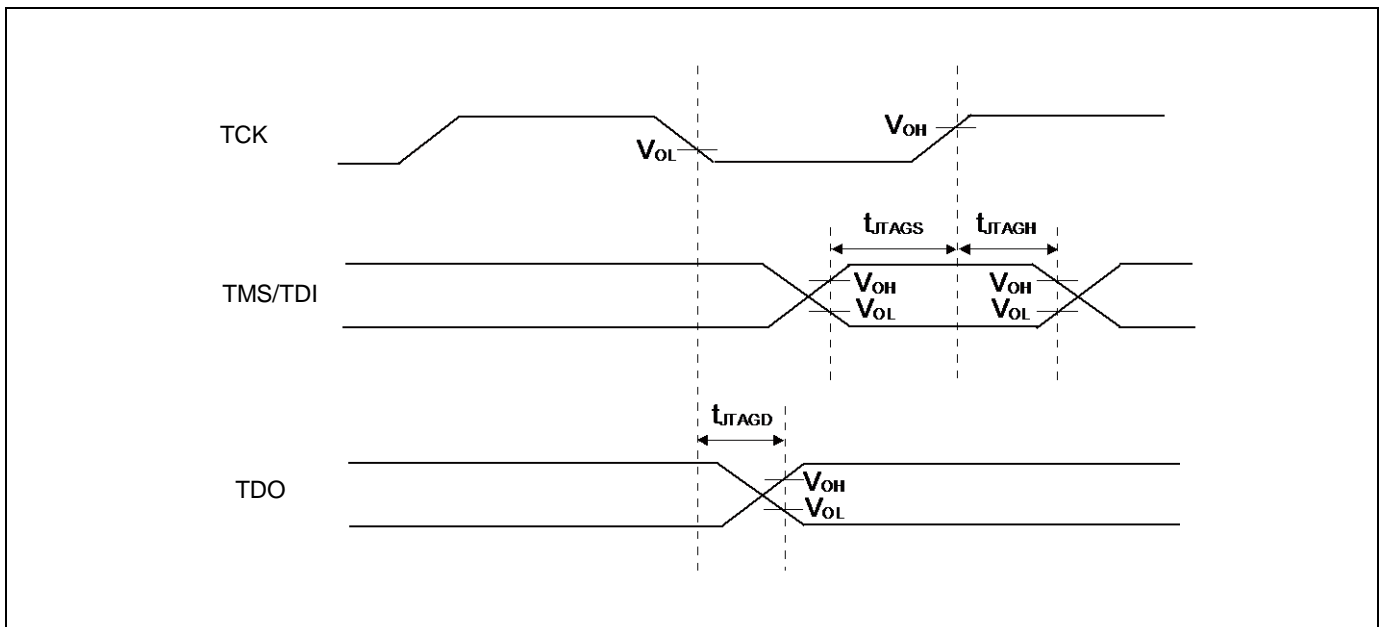

14.4.19 Ethernet-MAC Timing

RMII transmission (100 Mbps/10 Mbps)

(ETHV_{CC} = 3.0V to 3.6V, 4.5V to 5.5V^{*1}, V_{SS} = 0V, C_L = 25 pF)

Parameter	Symbol	Pin Name	Conditions	Value		Unit
				Min	Max	
Reference clock cycle time ^{*2}	t _{REFCYC}	E_RXCK_REFCK	20ns (typical)	-	-	ns
Reference clock High-pulse-width duty cycle	t _{REFCYCH}	E_RXCK_REFCK	t _{REFCYCH} /t _{REFCYC}	35	65	%
Reference clock Low-pulse-width duty cycle	t _{REFCYCL}	E_RXCK_REFCK	t _{REFCYCL} /t _{REFCYC}	35	65	%
Transmitted data → REFCK ↑ delay time	t _{RMIITX}	E_TX03, E_RX02, E_TX01, E_TX00, E_TXEN	-	-	12	ns

1 : When ETHV = 4.5V to 5.5V, it is recommended to add a series resistor at the output pin to suppress the output current.

2 : The reference clock is fixed to 50 MHz in the RMII specifications. The clock accuracy should meet the PHY-device specifications.

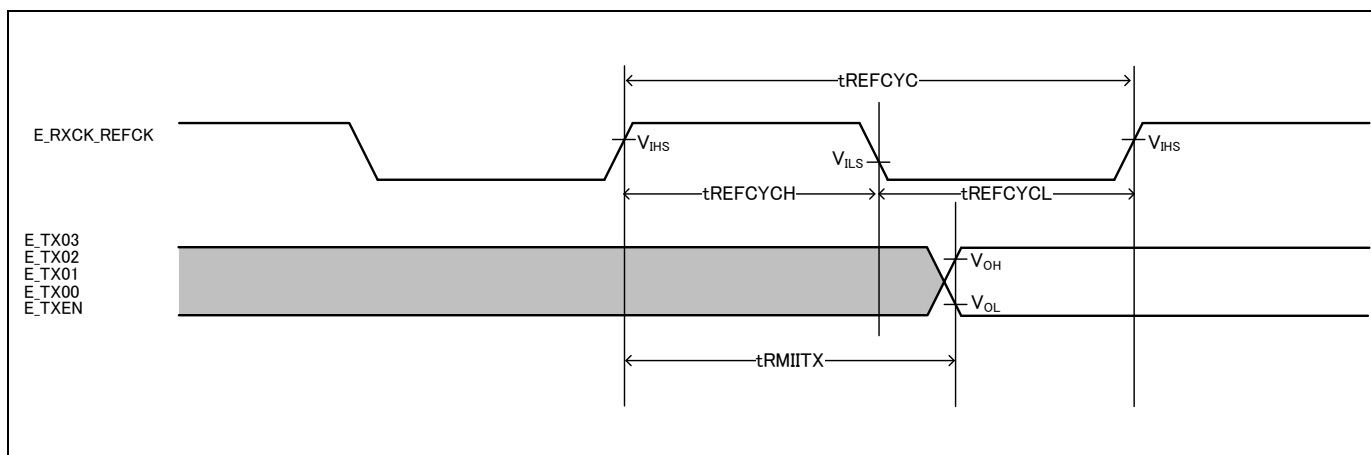

RMII receiving (100 Mbps/10 Mbps)

(ETHV_{CC} = 3.0V to 3.6V, 4.5V to 5.5V, V_{SS} = 0V, C_L = 25 pF)

Parameter	Symbol	Pin Name	Conditions	Value		Unit
				Min	Max	
Reference clock cycle time*	t _{REFCYC}	E_RXCK_REFCK	20 ns (typical)	-	-	ns
Reference clock High-pulse-width duty cycle	t _{REFCYCH}	E_RXCK_REFCK	t _{REFCYCH} /t _{REFCYC}	35	65	%
Reference clock Low-pulse-width duty cycle	t _{REFCYCL}	E_RXCK_REFCK	t _{REFCYCL} /t _{REFCYC}	35	65	%
Received data → REFCK ↑ Setup time	t _{RMIIRXS}	E_RX03, E_RX02, E_RX01, E_RX00, E_RXDV	-	4	-	ns
Received data → REFCK ↑ Hold time	t _{RMIIRXH}	E_RX03, E_RX02, E_RX01, E_RX00, E_RXDV	-	2	-	ns

* : The reference clock is fixed to 50 MHz in the RMII specifications.
The clock accuracy should meet the PHY-device specifications.

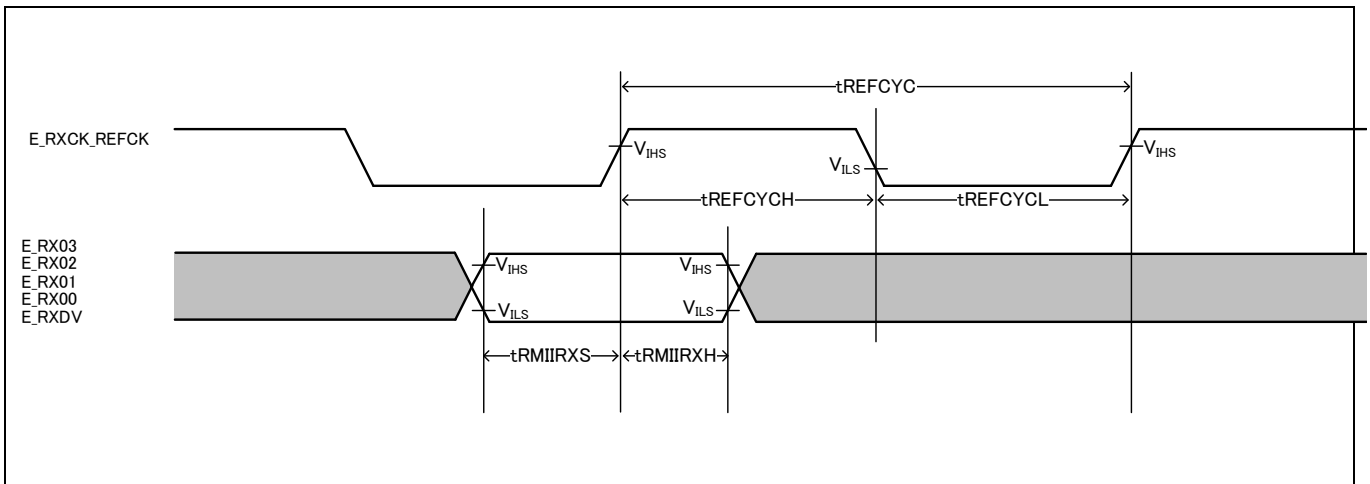

Management Interface

(ETHV_{CC} = 3.0V to 3.6V, 4.5V to 5.5V, V_{SS} = 0V, C_L = 25 pF)

Parameter	Symbol	Pin Name	Conditions	Value		Unit
				Min	Max	
Management clock cycle time*	t _{MDCYC}	E_MDC	-	400	-	ns
Management clock High pulse width duty cycle	t _{MDCYCH}	E_MDC	t _{MDCYCH} /t _{MDCYC}	35	65	%
Management clock Low pulse width duty cycle	t _{MDCYCL}	E_MDC	t _{MDCYCL} /t _{MDCYC}	35	65	%
MDC ↓ → MDIO Delay time	t _{MDO}	E_MDIO	-	-	60	ns
MDIO → MDC ↑ Setup time	t _{MDIS}	E_MDIO	-	20	-	ns
MDC ↑ → MDIO Hold time	t _{MDIH}	E_MDIO	-	0	-	ns

* : The clock time should be set to a value greater than the minimum value by setting the Ethernet-MAC setting register.

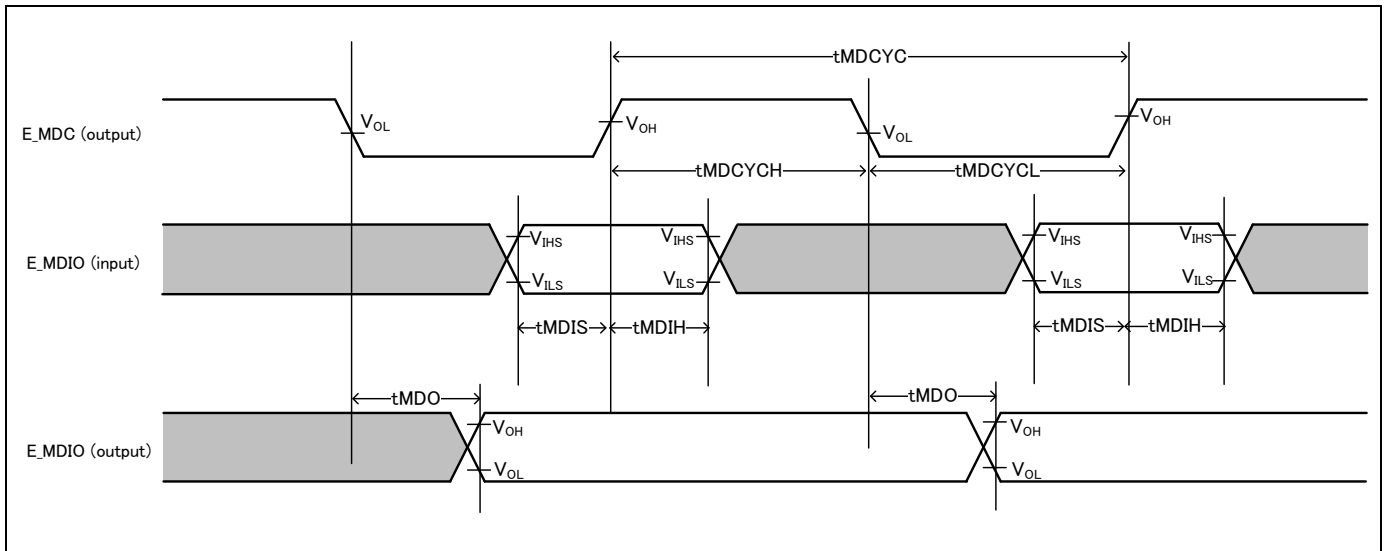

MII Transmission (100 Mbps/10 Mbps)

(ETHV_{CC} = 3.0V to 3.6V, 4.5V to 5.5V^{*1}, V_{SS} = 0V, CL = 25 pF)

Parameter	Symbol	Pin Name	Conditions	Value		Unit
				Min	Max	
Transmission clock Cycle time ^{*2}	t _{TXCYC}	E_TCK	100 Mbps 40 ns (typical)	-	-	ns
			100 Mbps 400 ns (typical)	-	-	ns
Transmission clock High-pulse-width duty cycle	t _{TXCYCH}	E_TCK	t _{TXCYCH} /t _{TXCYC}	35	65	%
Transmission CLOCK Low-pulse-width duty cycle	t _{TXCYCL}	E_TCK	t _{TXCYCL} /t _{TXCYC}	35	65	%
TXCK ↑ → Transmitted data delay time	t _{MITX}	E_TX03, E_TX02, E_TX01, E_TX00, E_TXEN	-	-	24	ns

- 1 : When ETHV = 4.5V to 5.5V, it is recommended to add a series resistor at the output pin to suppress the output current.
- 2 : The transmission clock is fixed to 25 MHz or 2.5 MHz in the MII specifications. The clock accuracy should meet the PHY-device specifications.

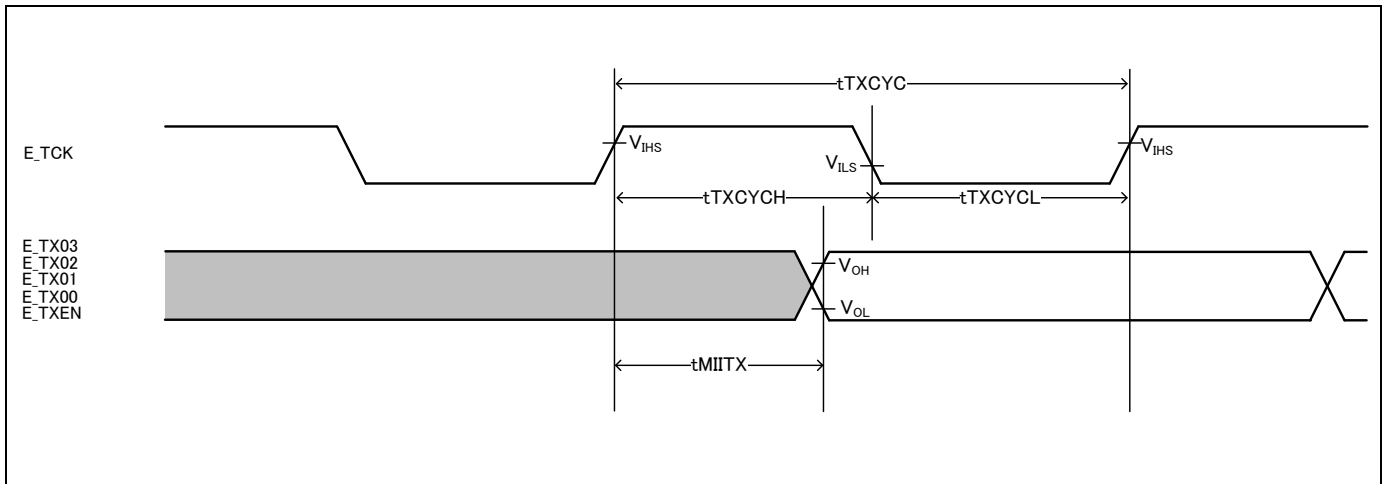

MII receiving (100 Mbps/10 Mbps)

(ETHV_{CC} = 3.0V to 3.6V, 4.5V to 5.5V, V_{SS} = 0V, C_L = 25 pF)

Parameter	Symbol	Pin Name	Conditions	Value		Unit
				Min	Max	
Receiving clock cycle time*	t _{RXCYC}	E_RXCK_REFCK	100 Mbps 40 ns (typical)	-	-	ns
			100 Mbps 400 ns (typical)	-	-	ns
Receiving clock High pulse width duty cycle	t _{RXCYCH}	E_RXCK_REFCK	t _{RXCYCH} /t _{RXCYC}	35	65	%
Receiving clock Low pulse width duty cycle	t _{RXCYCL}	E_RXCK_REFCK	t _{RXCYCL} /t _{RXCYC}	35	65	%
Received data → REFCK ↑ Setup time	t _{MIRXS}	E_RX03, E_RX02, E_RX01, E_RX00, E_RXDV	-	5	-	ns
REFCK ↑ → Received data Hold time	t _{MIRXH}	E_RX03, E_RX02, E_RX01, E_RX00, E_RXDV	-	2	-	ns

* : The reference clock is fixed to 50 MHz in the RMII specifications.
The clock accuracy should meet the PHY-device specifications.

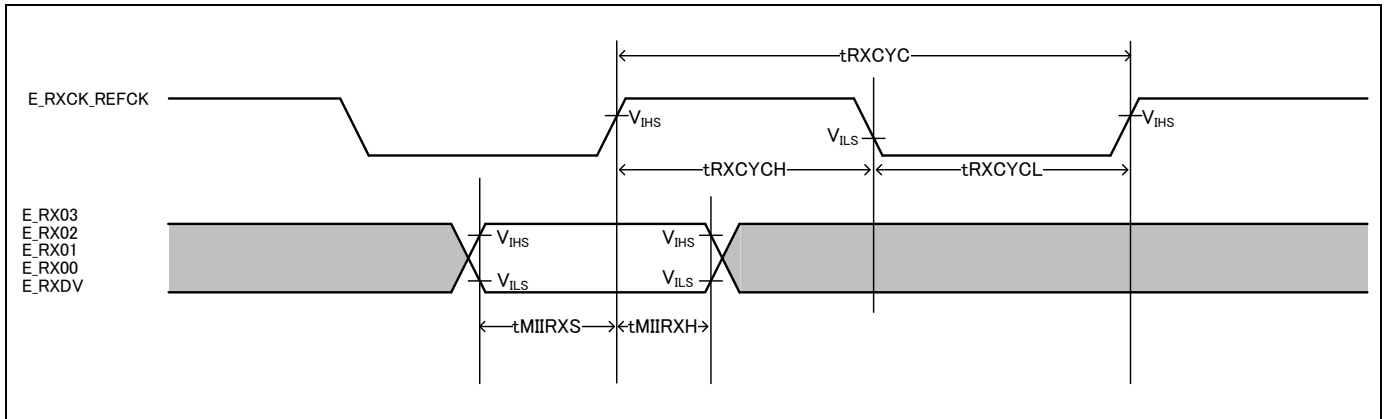

14.4.20 I²S Timing

Master Mode Timing

 (V_{CC} = 2.7V to 5.5V, V_{SS} = 0V)

Parameter	Symbol	Pin Name	Conditions	Value		Unit	Remarks
				Min	Max		
Output frequency	t _{mcy}	I2SCK	-	-	12.288	MHz	
Output clock pulse width	t _{mhw}	I2SCK	-	45	55	%	
	t _{mlw}			45	55	%	
I2SCK→I2SWS delay time	t _{dfs}	I2SCK, I2SWS	-	0	24.0	ns	
I2SCK→I2SDO delay time*	t _{ddo}	I2SCK, I2SDO	-	0	24.0	ns	
I2SDI→I2SCK setup time	t _{hstdi}	I2SCK, I2SDI	-	25.0	-	ns	
I2SDI→I2SCK hold time	t _{hdi}		-	0	-	ns	
Input signal rise time	t _{fi}	I2SDI	-	-	5	ns	
Input signal fall time	t _{fi}		-	-	5	ns	

* : Except for the first bit of transmission frame

Note:

- When the external load capacitance C_L = 20 pF
- When I2SWS = 48 kHz, I2MCLK = 256 × I2SWS
 Frame synchronization signal (I2SWS) is settable to 48 kHz, 32 kHz, 16 kHz.
 See "Chapter 7-2: I²S (Inter-IC Sound bus) Interface" in "FM4 Family Peripheral Manual Communication Macro Part (MN709-00004)" for the details.

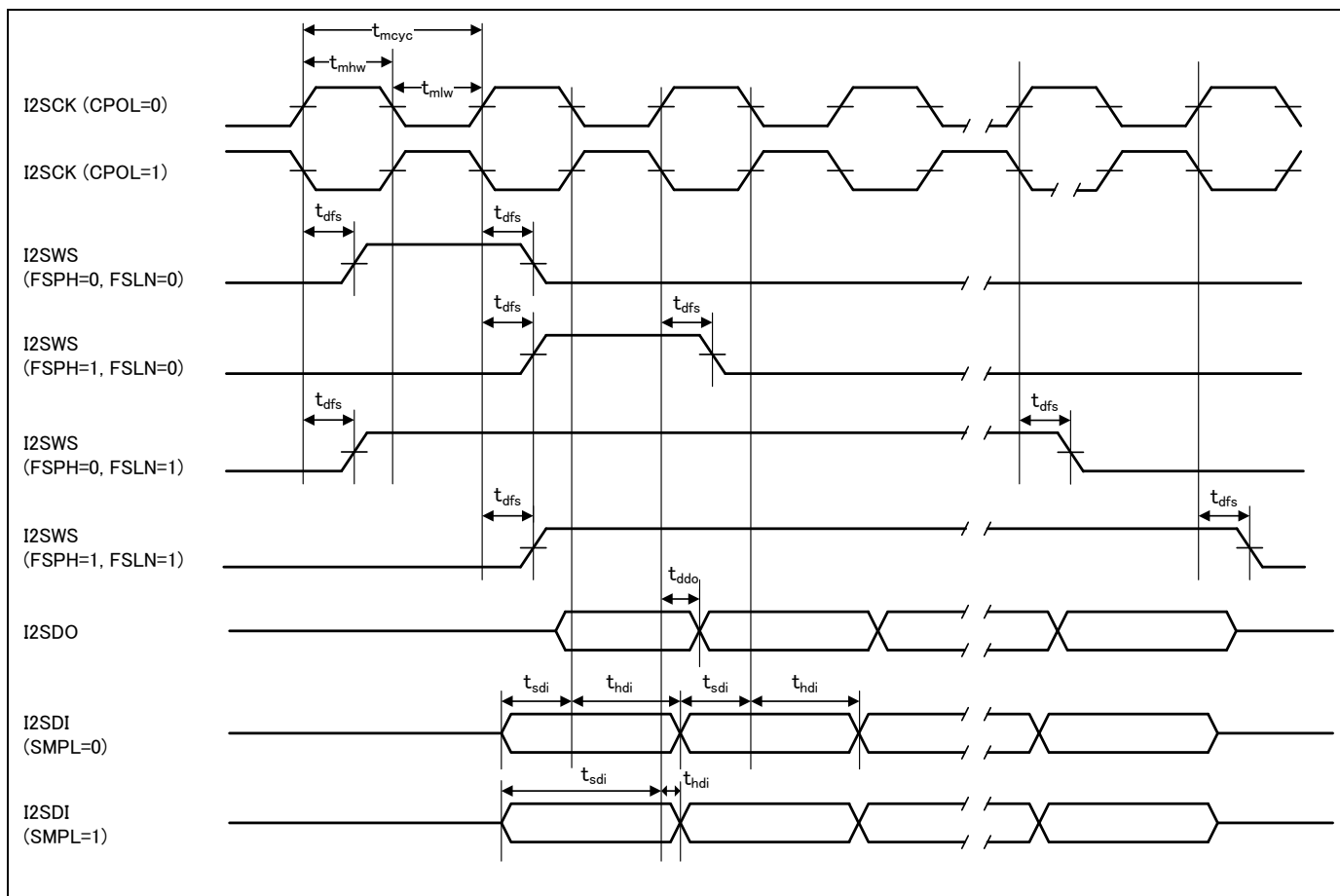

Note:

- See "Chapter 7-2: I²S (Inter-IC Sound bus) Interface" in "FM4 Family Peripheral Manual Communication Macro Part (MN709-00004)" for the details of CPOL, FSPH, FSLIN, and SMPL.

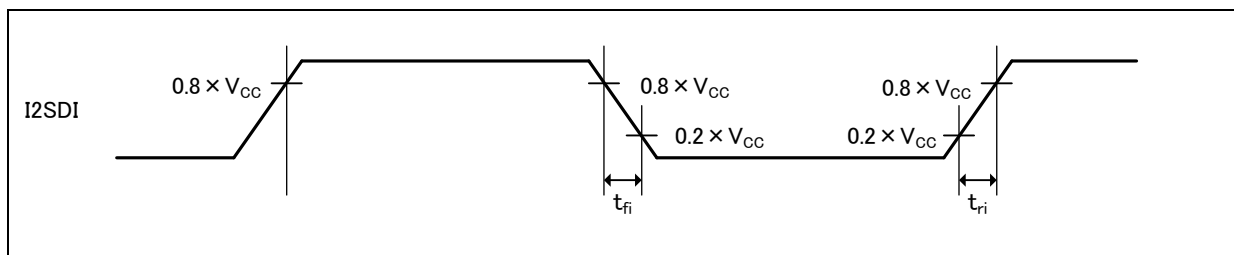

Slave Mode Timing

 (V_{CC} = 2.7V to 5.5V, V_{SS} = 0V)

Parameter	Symbol	Pin Name	Conditions	Value		Unit	Remarks
				Min	Max		
Input frequency	t _{sync}	I2SCK	-	-	12.288	MHz	
Input clock pulse width	t _{shw}	I2SCK	-	45	55	%	
	t _{slw}			45	55	%	
I2SWS→I2SCK Setup time	t _{sfi}	I2SCK, I2SWS	-	8	-	ns	
I2SWS→I2SCK Hold time	t _{hfi}	I2SCK, I2SWS	-	0	-	ns	
I2SCK ↑ →I2SDO Delay time ^{*1}	t _{ddo}	I2SCK, I2SDO	-	0	32	ns	
I2SCK ↑ →I2SDO Delay time ^{*2}	t _{dfb1}		-	0	32	ns	
I2SDI→I2SCK ↓ Setup time	t _{sdi}	I2SCK, I2SDI	-	8	-	ns	
I2SDI→I2SCK ↓ Hold time	t _{hdi}		-	0	-	ns	
Input signal rise time	t _{ri}	I2SCK, I2SWS,	-	-	5	ns	
Input signal fall time	t _{fi}	I2SDI	-	-	5	ns	

1 : Except for the first bit of transmission frame

2 : When FSPH bit = 1.

Note:

- When the external load capacitance C_L = 20 pF
- When I2SWS = 48 kHz, I2MCLK = 256 × I2SWS

Frame synchronization signal (I2SWS) is settable to 48 kHz, 32 kHz, 16 kHz. See "Chapter7-2: I²S (Inter-IC Sound bus) Interface" in "FM4 Family Peripheral Manual Communication Macro Part (MN709-00004)" for the details.

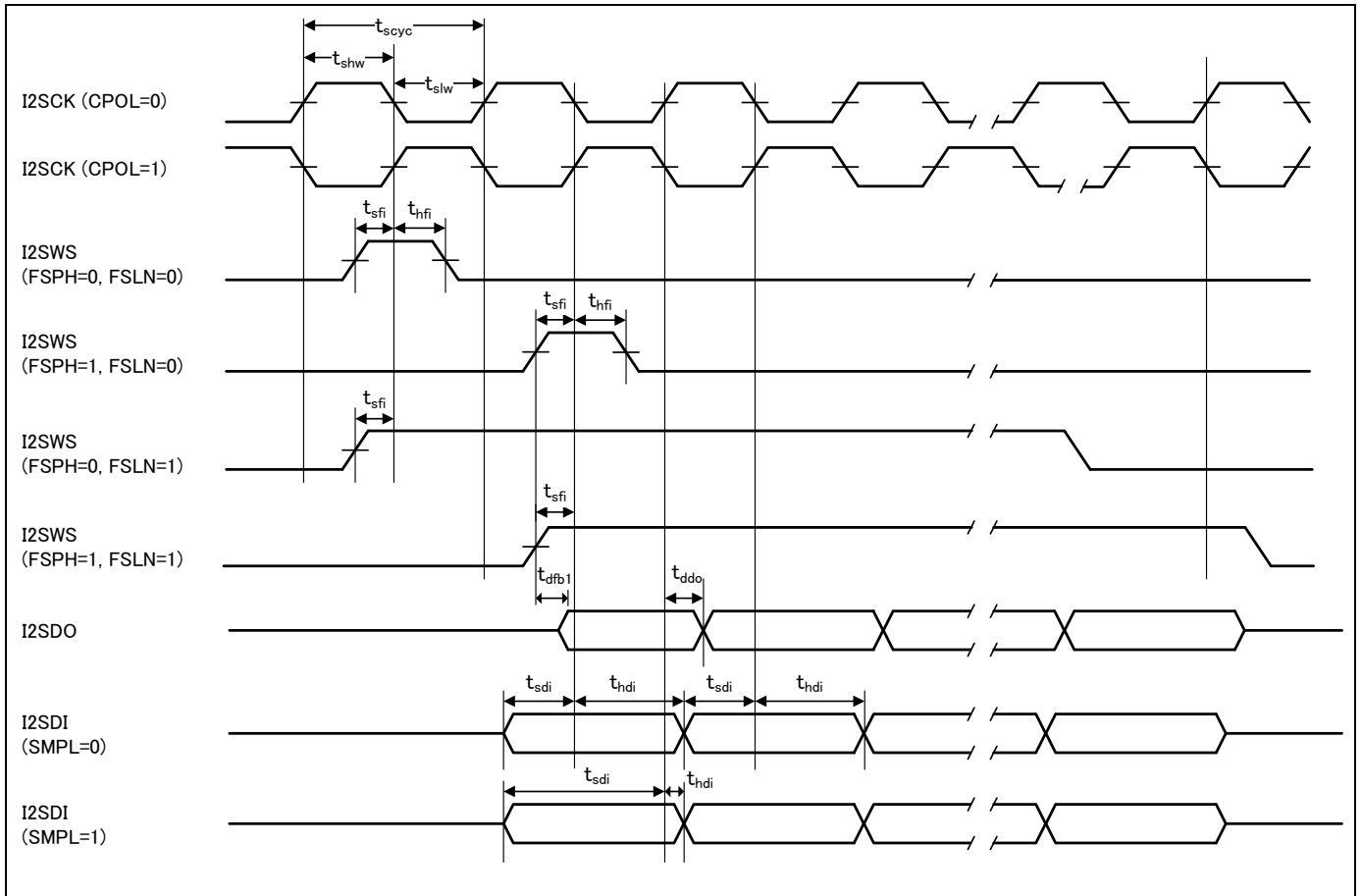

Note:

- See "Chapter 7-2: I²S (Inter-IC Sound bus) Interface" in "FM4 Family Peripheral Manual Communication Macro Part (MN709-00004)" for the details of FSPH, FSLN, SMPL
- I2SCK input is selectable polarity by CPOL bit of CNTREG register

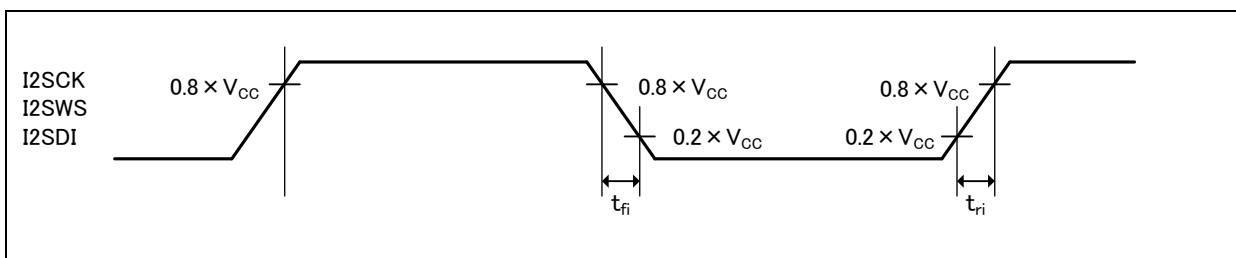

I2SMCLK Input Characteristics

($V_{CC} = 2.7V$ to $5.5V$, $V_{SS} = 0V$)

Parameter	Symbol	Pin Name	Conditions	Value		Unit	Remarks
				Min	Max		
Input frequency	F_{CHS}	I2SCK	-	-	25	MHz	
Input clock cycle	t_{CYLHS}	-	-	40	-	ns	
Input clock pulse width	-	-	P_{WHS}/t_{CYLHS} P_{WLS}/t_{CYLHS}	45	55	%	When using external clock
Input clock rise time and fall time	t_{CFS} t_{CRS}	-	-	-	5	ns	When using external clock

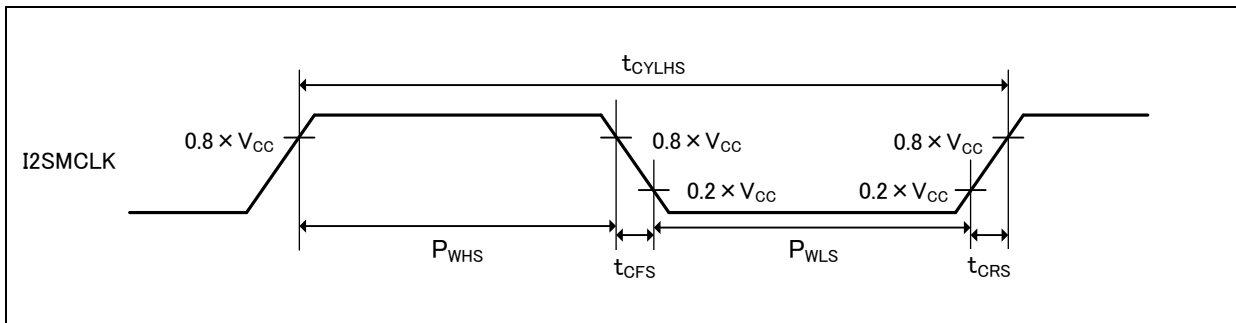

I2SMCLK Output Characteristics

($V_{CC} = 2.7V$ to $5.5V$, $V_{SS} = 0V$)

Parameter	Symbol	Pin Name	Conditions	Value		Unit	Remarks
				Min	Max		
Input frequency	F_{CHS}	I2SCK	-	-	12.288	MHz	

14.4.21 High-Speed Quad SPI Timing

(V_{CC} = 2.7V to 3.6V, V_{SS} = 0V)

Parameter	Symbol	Pin Name	Conditions	Value		Unit	Remarks
				Min	Max		
Serial clock frequency	t _{SCYCM}	Q_SCK_0	C _L = 15 pF, V _{CC} = 3.0 to 3.6V	-	66	MHz	*1
			C _L = 30 pF	-	50	MHz	*2
Enabled CS→ CLK Starting Time (mode0/mode2)	t _{OSLSK02}	Q_SCK_0, Q_CS0_0, Q_CS1_0, Q_CS2_0	C _L = 30 pF	1.5 × t _{SCYCM} - 5	-	ns	
Enabled CS→ CLK Starting Time (mode1/mode3)	t _{OSLSK13}			t _{SCYCM} - 5	-	ns	
CLK Last→ Disabled CS Time (mode0/mode2)	t _{OSKSL02}			t _{SCYCM}	-	ns	
CLK Last→ Disabled CS Time (mode1/mode3)	t _{OSKSL13}			1.5 × t _{SCYCM}	-	ns	
SIO Data output time	t _{OSDAT}	Q_SCK_0, Q_IO0_0, Q_IO1_0,	C _L = 15 pF, V _{CC} = 3.0 to 3.6V	0	5	ns	
			C _L = 30 pF	0	5		
SIO Setup	t _{DSSSET}	Q_IO2_0, Q_IO3_0	C _L = 30 pF	3	-	ns	*1
				10	-		*2
SIO Hold	t _{SDHOLD}		C _L = 30 pF	0.5 × t _{SCYCM}	-	ns	

1 : When "RTM = 1 and mode = 0, 1, 3"

2 : When "RTM = 1 and mode = 2" or "RTM = 0 and mode = 0, 1, 2, 3"

Note:

- See "Chapter8-3: High-Speed Quad SPI controller" in "FM4 Family Peripheral Manual Communication Macro Part (MN709-00004)" for the detail of RTM mode.
- When using High-Speed Quad SPI, please set PDSR register to set the pin drive capability for V_{CC} = 3V. See "Chapter12: I/O Port" in "FM4 Family Peripheral Manual Main Part (MN709-00001)" for the details.

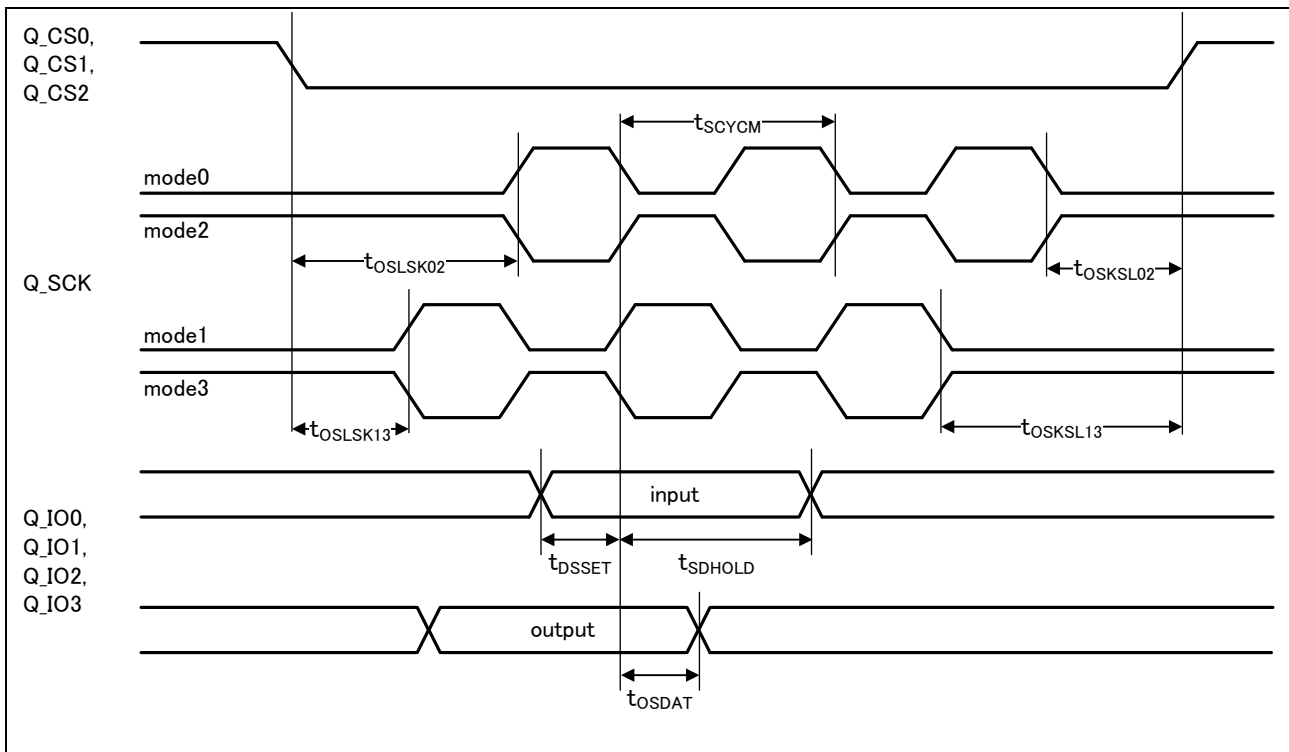

14.5 12-bit A/D Converter

Electrical Characteristics for the A/D Converter

($V_{CC} = AV_{CC} = 2.7V$ to $5.5V$, $V_{SS} = AV_{SS} = AV_{RL} = 0V$)

Parameter	Symbol	Pin Name	Value			Unit	Remarks
			Min	Typ	Max		
Resolution	-	-	-	-	12	bit	
Integral nonlinearity	-	-	- 4.5	-	+ 4.5	LSB	AVRH = 2.7V to 5.5V
Differential nonlinearity	-	-	- 2.5	-	+ 2.5	LSB	
Zero transition voltage	V_{ZT}	AN00 to AN31	- 15	-	+ 15	mV	
Full-scale transition voltage	V_{FST}	AN00 to AN31	AVRH - 15	-	AVRH + 15	mV	
			AV _{CC} - 15	-	AV _{CC} + 15	mV	
Conversion time	-	-	0.5 ^{*1}	-	-	μs	AV _{CC} ≥ 4.5V
Sampling time	T_s	-	*2	-	10	μs	AV _{CC} ≥ 4.5V
			*2	-			AV _{CC} < 4.5V
Compare clock cycle ^{*3}	T_{cck}	-	25	-	1000	ns	AV _{CC} ≥ 4.5V
			50	-	1000		AV _{CC} < 4.5V
State transition time to operation permission	T_{stt}	-	1.0	-	-	μs	
Power supply current (analog + digital)	-	AV _{CC}	-	0.69	0.92	mA	A/D 1 unit operation
			-	1.3	22		μA
Reference power supply current (between AVRH and AVSS)	-	AVRH	-	1.1	1.97	mA	A/D 1 unit operation AVRH = 5.5V
			-	0.3	6.3		μA
Analog input capacity	C_{AIN}	-	-	-	12.05	pF	
Analog input resistance	R_{AIN}	-	-	-	1.2	kΩ	AV _{CC} ≥ 4.5V
					1.8		AV _{CC} < 4.5V
Interchannel disparity	-	-	-	-	4	LSB	
Analog port input current	-	AN00 to AN31	-	-	5	μA	
Analog input voltage	-	AN00 to AN31	AV _{SS}	-	AVRH	V	
			AV _{SS}	-	AV _{CC}		V
Reference voltage	-	AVRH	4.5	-	AV _{CC}	V	$T_{cck} < 50ns$
			2.7	-	AV _{CC}		$T_{cck} \geq 50 ns$

1 : The conversion time is the value of sampling time (T_s) + compare time (T_c).

The condition of the minimum conversion time is when the value of $T_s = 150 ns$ and $T_c = 350 ns$ ($AV_{CC} \geq 4.5V$). Ensure that it satisfies the value of sampling time (T_s) and compare clock cycle (T_{cck}). For setting^{*4} of sampling time and compare clock cycle, see "Chapter 1-1: A/D Converter" in "FM4 Family Peripheral Manual Analog Macro Part (MN709-00003)." The register setting of the A/D converter is reflected by the peripheral clock timing. The sampling and compare clock are set at base clock (HCLK).

2 : A necessary sampling time changes by external impedance. Ensure that it sets the sampling time to satisfy (Equation 1).

3 : The compare time (T_c) is the value of (Equation 2).

4 : The register setting of the A/D converter is reflected by the timing of the APB bus clock. The sampling clock and compare clock are set in the base clock (HCLK). For more information about the APB bus number to which the A/D converter is connected, see "10. Block Diagram" in this data sheet.

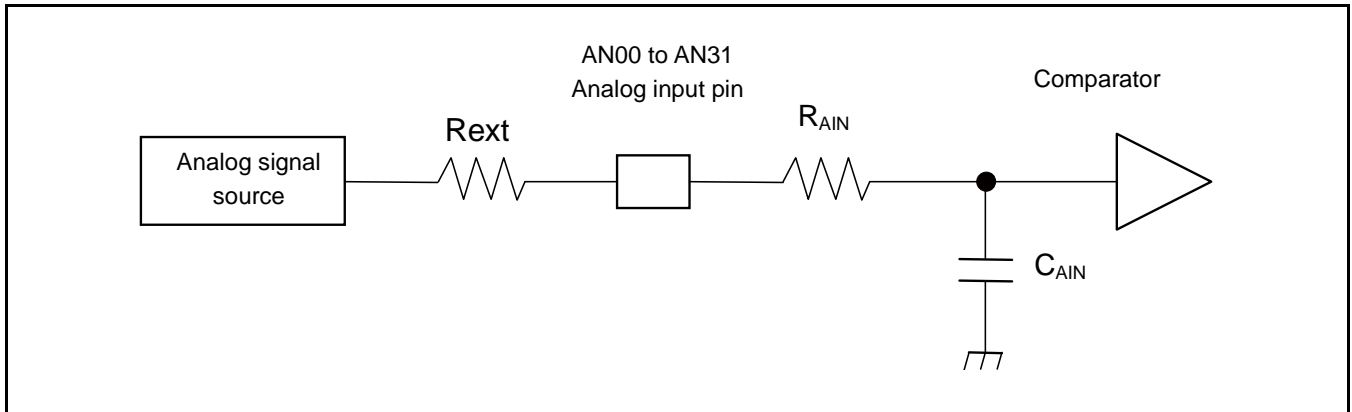

$$\text{(Equation 1) } T_s \geq (R_{AIN} + R_{ext}) \times C_{AIN} \times 9$$

T_s : Sampling time

R_{AIN} : Input resistance of A/D = 1.2 k Ω at $4.5V \leq AV_{CC} \leq 5.5V$

Input resistance of A/D = 1.8 k Ω at $2.7V \leq AV_{CC} < 4.5V$

C_{AIN} : Input capacity of A/D = 12.05 pF at $2.7V \leq AV_{CC} \leq 5.5V$

R_{ext} : Output impedance of external circuit

$$\text{(Equation 2) } T_c = T_{cck} \times 14$$

T_c : Compare time

T_{cck} : Compare clock cycle

Definition of 12-bit A/D Converter Terms

- Resolution : Analog variation that is recognized by an A/D converter.
- Integral Nonlinearity : Deviation of the line between the zero-transition point (0b000000000000 ↔ 0b000000000001) and the full-scale transition point (0b111111111110 ↔ 0b111111111111) from the actual conversion characteristics.
- Differential Nonlinearity: Deviation from the ideal value of the input voltage that is required to change the output code by 1 LSB.

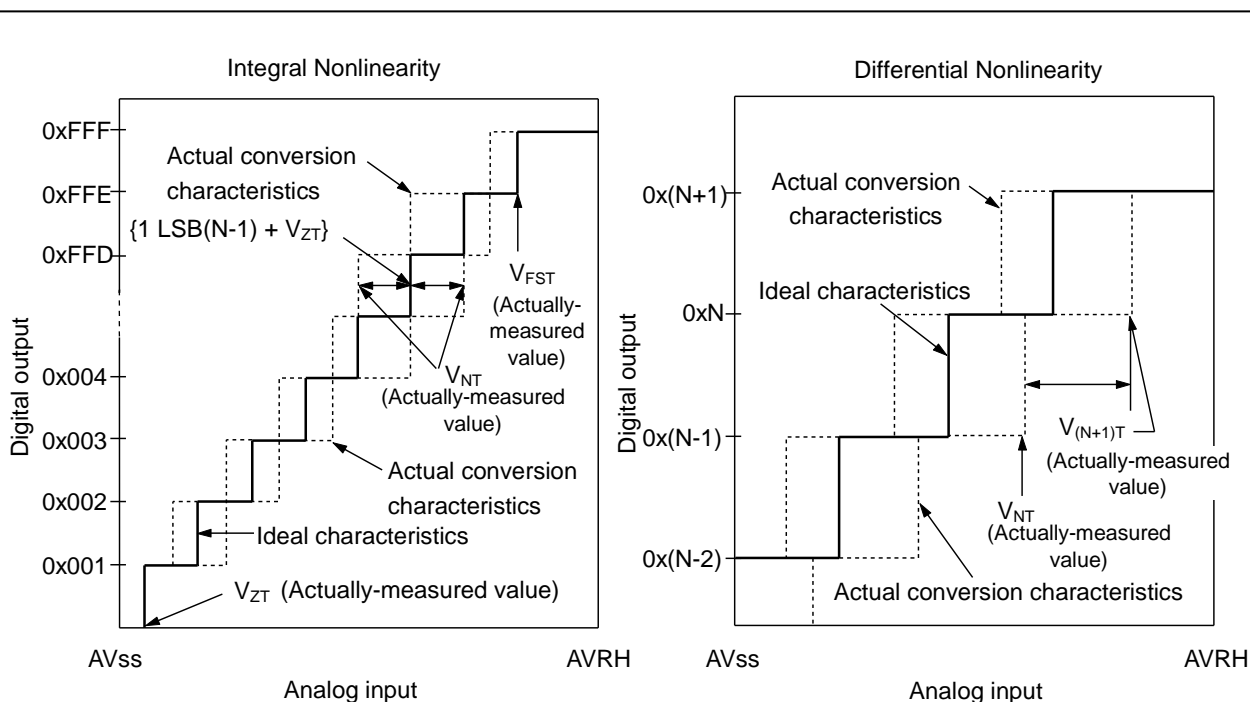

$$\text{Integral Nonlinearity of digital output } N = \frac{V_{NT} - \{1\text{LSB} \times (N - 1) + V_{ZT}\}}{1\text{LSB}} \text{ [LSB]}$$

$$\text{Differential Nonlinearity of digital output } N = \frac{V_{(N+1)T} - V_{NT}}{1\text{LSB}} - 1 \text{ [LSB]}$$

$$1\text{LSB} = \frac{V_{FST} - V_{ZT}}{4094}$$

N : A/D converter digital output value.

V_{ZT} : Voltage at which the digital output changes from 0x000 to 0x001.

V_{FST} : Voltage at which the digital output changes from 0xFFE to 0xFFF.

V_{NT} : Voltage at which the digital output changes from 0x(N - 1) to 0xN.

14.6 12-bit D/A Converter

Electrical Characteristics for the D/A Converter

($V_{CC} = AV_{CC} = 2.7V$ to $5.5V$, $V_{SS} = AV_{SS} = 0V$)

Parameter	Symbol	Pin Name	Value			Unit	Remarks
			Min	Typ	Max		
Resolution	-	DA0, DA1	-	-	12	bit	
Conversion time	tc20		0.56	0.69	0.81	μs	Load 20 pF
	tc100		2.79	3.42	4.06	μs	Load 100 pF
Integral nonlinearity *	INL		- 16	-	+ 16	LSB	
Differential nonlinearity *	DNL		- 0.98	-	+ 1.5	LSB	
Output voltage offset	V_{OFF}		-	-	+ 10	mV	When setting 0x000
			- 20.0	-	+ 1.4	mV	When setting 0xFFFF
Analog output impedance	R_O		3.10	3.80	4.50	k Ω	D/A operation
		2.0	-	-	M Ω	When D/A stop	
Power supply current *	IDDA	AVCC	260	330	410	μs	D/A 1ch operation $AV_{CC} = 3.3V$
			400	510	620	μs	D/A 1ch operation $AV_{CC} = 5.0V$
	IDSA		-	-	14	μs	When D/A stop

* : During no load

14.7 USB Characteristics

($V_{CC} = AV_{CC} = 2.7V$ to $5.5V$, $USBV_{CC0} = USBV_{CC1} = 3.0V$ to $3.6V$, $V_{SS} = AV_{SS} = 0V$)

Parameter	Symbol	Pin Name	Conditions	Value		Unit	Remarks
				Min	Max		
Input characteristics	Input "H" level voltage	V_{IH}	-	2.0	$USBV_{CC} + 0.3$	V	*1
	Input "L" level voltage	V_{IL}	-	$V_{SS} - 0.3$	0.8	V	*1
	Differential input sensitivity	V_{DI}	-	0.2	-	V	*2
	Different common mode range	V_{CM}	-	0.8	2.5	V	*2
Output characteristics	Output "H" level voltage	V_{OH}	External pull-down resistance = 15 k Ω	2.8	3.6	V	*3
	Output "L" level voltage	V_{OL}	External pull-up resistance = 1.5 k Ω	0.0	0.3	V	*3
	Crossover voltage	V_{CRS}	-	1.3	2.0	V	*4
	Rise time	t_{FR}	Full-Speed	4	20	ns	*5
	Fall time	t_{FF}	Full-Speed	4	20	ns	*5
	Rise/fall time matching	t_{FRFM}	Full-Speed	90	111.11	%	*5
	Output impedance	Z_{DRV}	Full-Speed	28	44	Ω	*6
	Rise time	t_{LR}	Low-Speed	75	300	ns	*7
	Fall time	t_{LF}	Low-Speed	75	300	ns	*7
	Rise/fall time matching	t_{LRFM}	Low-Speed	80	125	%	*7

1 : The switching threshold voltage of the single-end-receiver of USB I/O buffer is set as within V_{IL} (Max) = 0.8V, V_{IH} (Min) = 2.0V (TTL input standard).

There is some hysteresis applied to lower noise sensitivity.

2 : Use differential-receiver to receive USB differential data signal. Differential-receiver has 200 mV of differential input sensitivity when the differential data input is within 0.8V to 2.5V to the local ground reference level.

Above voltage range is the common mode input voltage range.

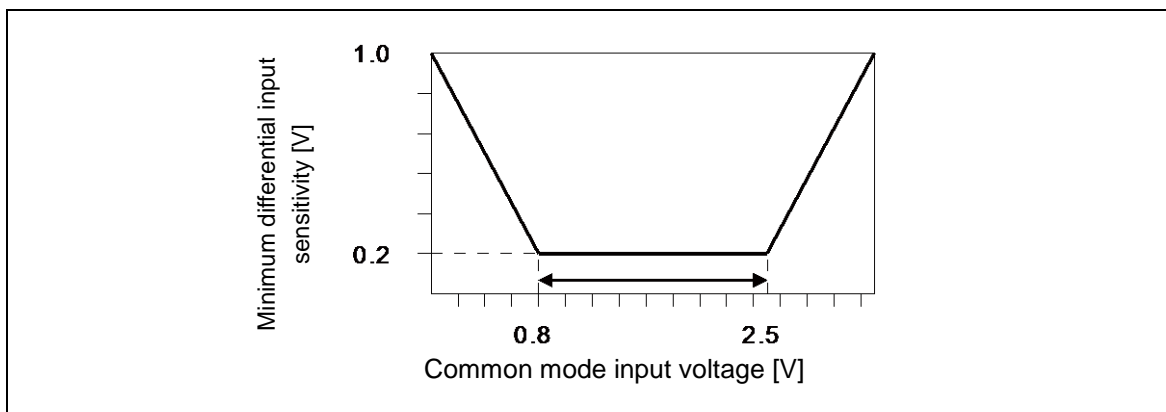

- 3 : The output drive capability of the driver is below 0.3V at low state (V_{OL}) (to 3.6V and 1.5 k Ω load), and 2.8V or above (to the VSS and 1.5 k Ω load) at high state (V_{OH}).
- 4 : The cross voltage of the external differential output signal (D +/D -) of USB I/O buffer is within 1.3V to 2.0V.

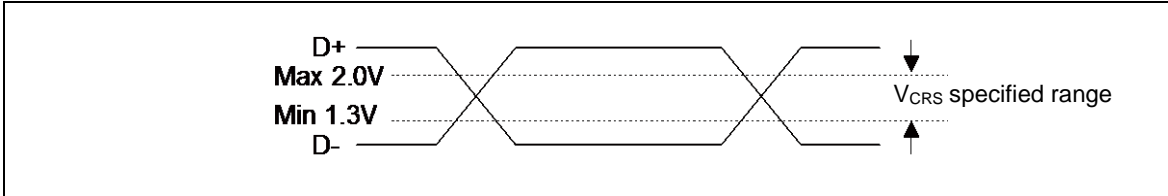

- 5 : They indicate rise time (T_{rise}) and fall time (T_{fall}) of the full-speed differential data signal. They are defined by the time between 10% and 90% of the output signal voltage. For full-speed buffer, T_r/T_f ratio is regulated as within $\pm 10\%$ to minimize RFI emission.

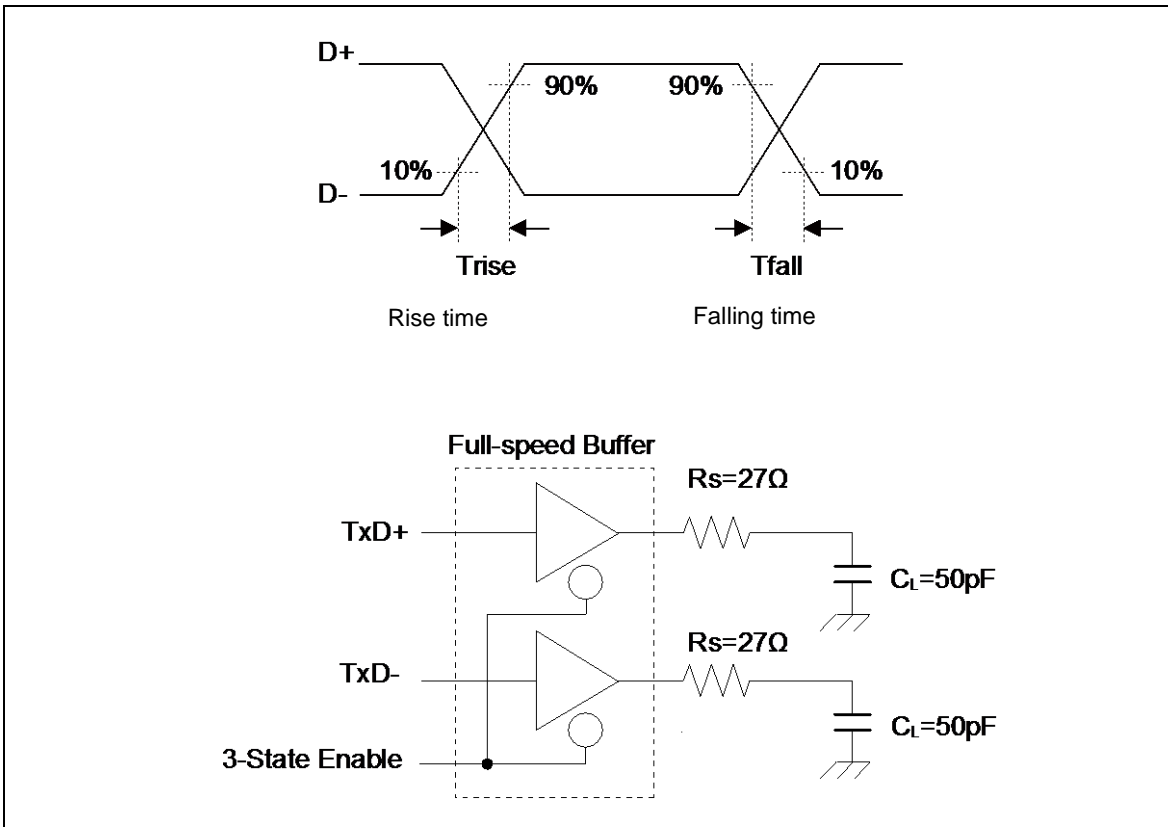

6 : USB Full-speed connection is performed via twisted-pair cable shield with $90\Omega \pm 15\%$ characteristic impedance (differential mode).

USB standard defines that the output impedance of the USB driver must be in the range from 28Ω to 44Ω . So, a discrete series resistor (R_s) addition is defined in order to satisfy the above definition and keep balance.

When using this USB I/O, use it with 25Ω to 30Ω (recommended value 27Ω) series resistor R_s .

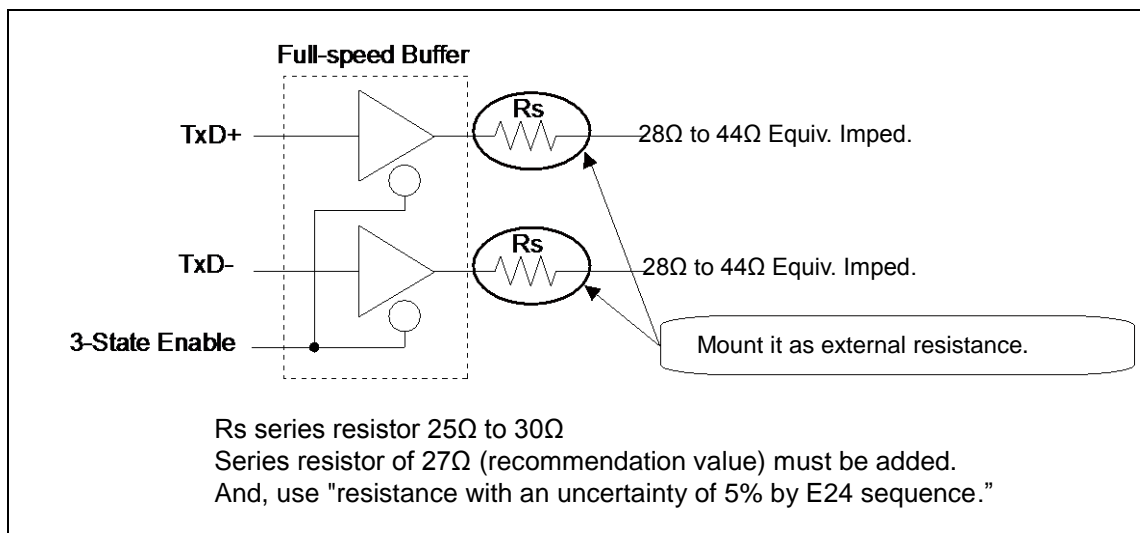

7 : They indicate rise time (T_{rise}) and fall time (T_{fall}) of the low-speed differential data signal.

They are defined by the time between 10% and 90% of the output signal voltage.

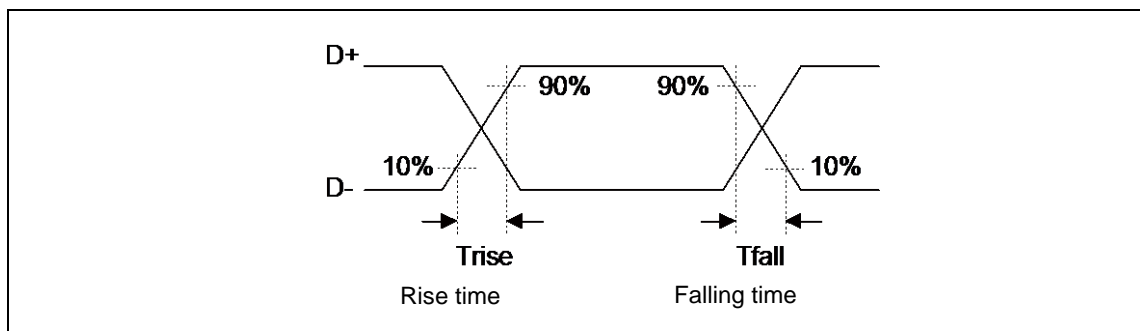

Note:

- See "Low-Speed Load (Compliance Load)" for conditions of external load.

Low-Speed Load (Upstream Port Load) - Reference 1

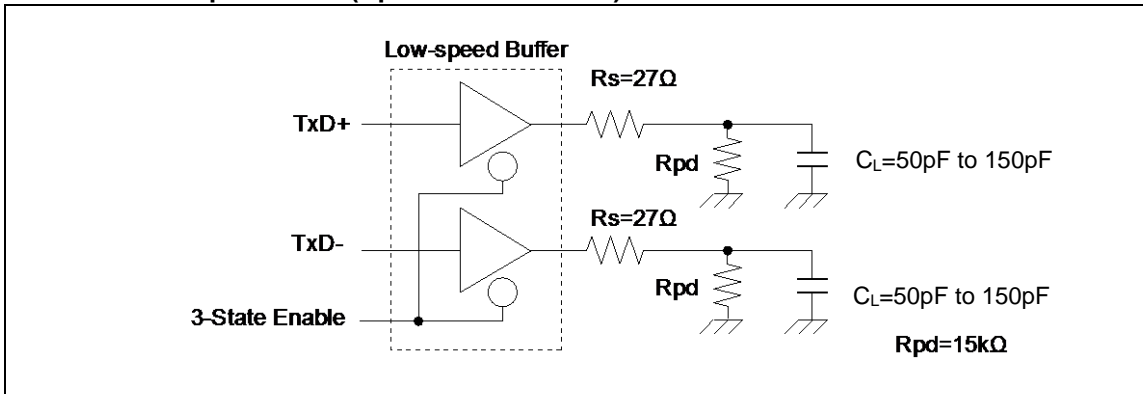

Low-Speed Load (Downstream Port Load) - Reference 2

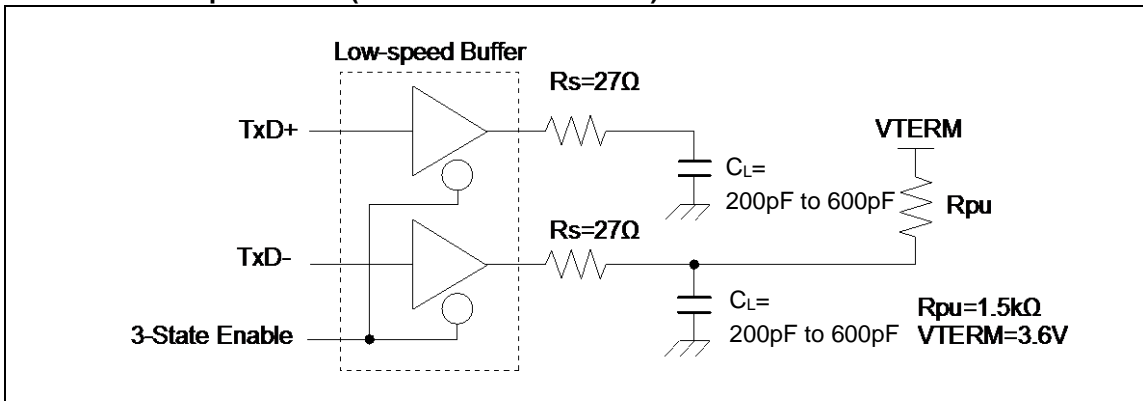

Low-Speed Load (Compliance Load)

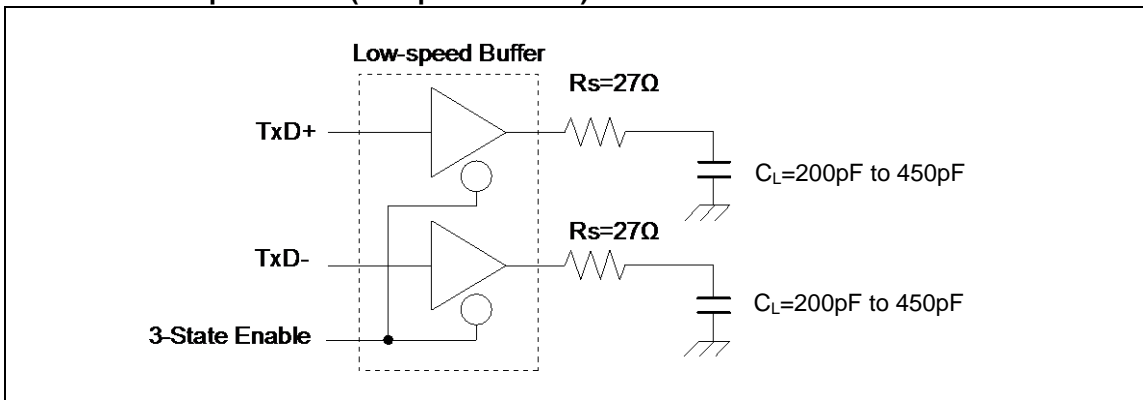

14.8 Low-Voltage Detection Characteristics

14.8.1 Low-Voltage Detection Reset

Parameter	Symbol	Conditions	Value			Unit	Remarks
			Min	Typ	Max		
Detected voltage	VDL	-	2.46	2.55	2.64	V	When voltage drops
Released voltage	VDH	-	2.51	2.60	2.69	V	When voltage rises

14.8.2 Interrupt of Low-Voltage Detection

Parameter	Symbol	Conditions	Value			Unit	Remarks
			Min	Typ	Max		
Detected voltage	VDL	SVHI = 0011	2.80	2.90	3.00	V	When voltage drops
Released voltage	VDH		2.90	3.00	3.11	V	When voltage rises
Detected voltage	VDL	SVHI = 0100	2.99	3.10	3.21	V	When voltage drops
Released voltage	VDH		3.09	3.20	3.31	V	When voltage rises
Detected voltage	VDL	SVHI = 0101	3.18	3.30	3.42	V	When voltage drops
Released voltage	VDH		3.28	3.40	3.52	V	When voltage rises
Detected voltage	VDL	SVHI = 0110	3.67	3.80	3.93	V	When voltage drops
Released voltage	VDH		3.76	3.90	4.04	V	When voltage rises
Detected voltage	VDL	SVHI = 0111	3.76	3.90	4.04	V	When voltage drops
Released voltage	VDH		3.86	4.00	4.14	V	When voltage rises
Detected voltage	VDL	SVHI = 1000	4.05	4.20	4.35	V	When voltage drops
Released voltage	VDH		4.15	4.30	4.45	V	When voltage rises
Detected voltage	VDL	SVHI = 1001	4.15	4.30	4.45	V	When voltage drops
Released voltage	VDH		4.25	4.40	4.55	V	When voltage rises
Detected voltage	VDL	SVHI = 1010	4.25	4.40	4.55	V	When voltage drops
Released voltage	VDH		4.34	4.50	4.66	V	When voltage rises
LVD stabilization wait time	T _{LVDW}	-	-	-	6000×t _{CYCP} *	μs	

* : t_{CYCP} indicates the APB2 bus clock cycle time.

14.9 MainFlash Memory Write/Erase Characteristics

(V_{CC} = 2.7V to 5.5V)

Parameter		Value			Unit	Remarks
		Min	Typ	Max		
Sector erase time	Large Sector	-	0.7	3.7	s	Includes write time prior to internal erase
	Small Sector	-	0.3	1.1	s	
Half word (16-bit) write time	Write cycles ≤ 100 times	-	12	100	μs	Not including system-level overhead time
	Write cycles > 100 times			200		
Chip erase time*		-	13.6	68	s	Includes write time prior to internal erase

* : It indicates the chip erase time of 1MB MainFlash memory
 For devices with 1.5 MB or 2 MB of MainFlash memory, two erase cycles are required.
 See “3.2.2 Command Operating Explanations” and “3.3.3 Flash Erase Operation” in this product's “Flash Programming Manual” for the detail.

Write Cycles and Data Retention Time

Erase/Write Cycles (Cycle)	Data Retention Time (Year)
1,000	20*
10,000	10*
100,000	5*

* : This value comes from the technology qualification (using Arrhenius equation to translate high temperature acceleration test result into average temperature value at + 85°C).

14.10 Dual Flash Memory Write/Erase Characteristics

It is the same write/erase characteristics as the MainFlash memory.
 See “3.6 Dual flash mode” in this product's “Flash Programming Manual” for the detail of dual flash mode.

14.11 Standby Recovery Time

14.11.1 Recovery cause: Interrupt/WKUP

The time from the interrupt occurring to the time of program operation start is shown.

Recovery count time

($V_{CC} = 2.7V$ to $5.5V$, $V_{SS} = 0V$)

Parameter	Symbol	Value		Unit	Remarks
		Typ	Max*		
Sleep mode	Ticnt	HCLKx1		μs	
High-speed CR timer mode Main timer mode PLL timer mode		40	80	μs	
Low-speed CR timer mode		450	900	μs	
Sub timer mode		896	1136	μs	
RTC mode Stop mode (High-speed CR/Main/PLL run mode return)		316	581	μs	
RTC mode Stop mode (Low-speed CR/sub run mode return)		270	540	μs	
Deep standby RTC mode with RAM retention Deep standby stop mode with RAM retention		365	667	μs	without RAM retention
		365	667	μs	with RAM retention

* : The maximum value depends on the built-in CR accuracy.

Example of Standby Recovery Operation (when in external interrupt recovery*)

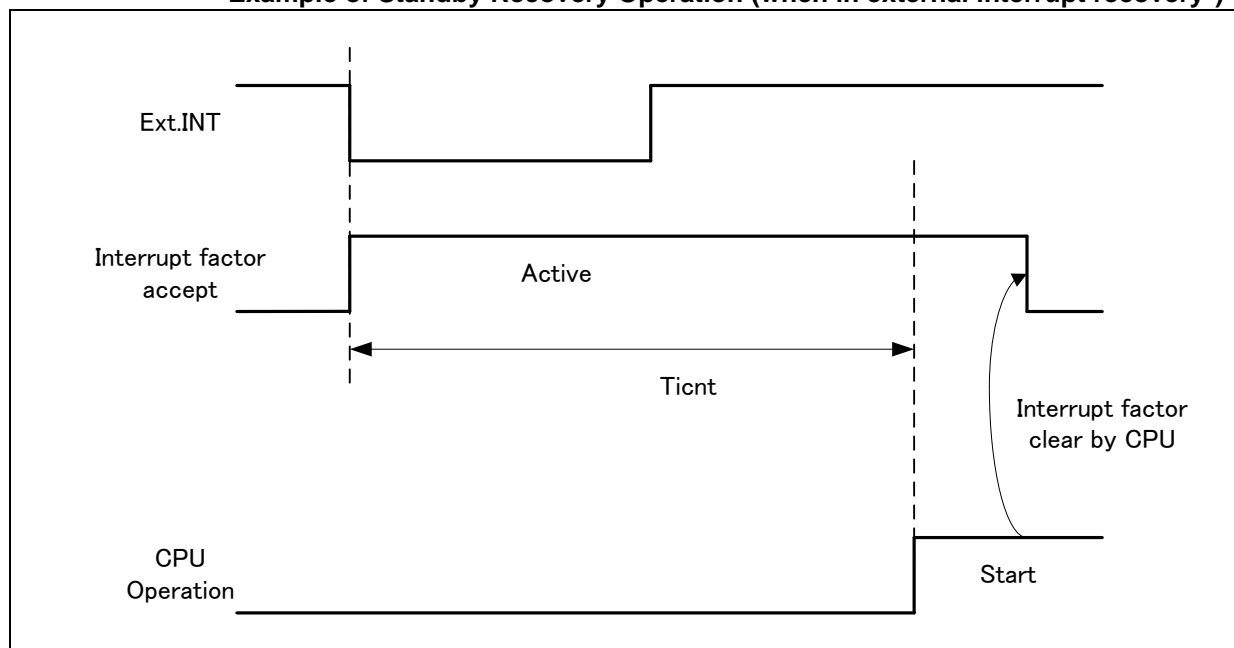

* : External interrupt is set to detecting fall edge.

Example of Standby Recovery Operation (when in internal resource interrupt recovery*)

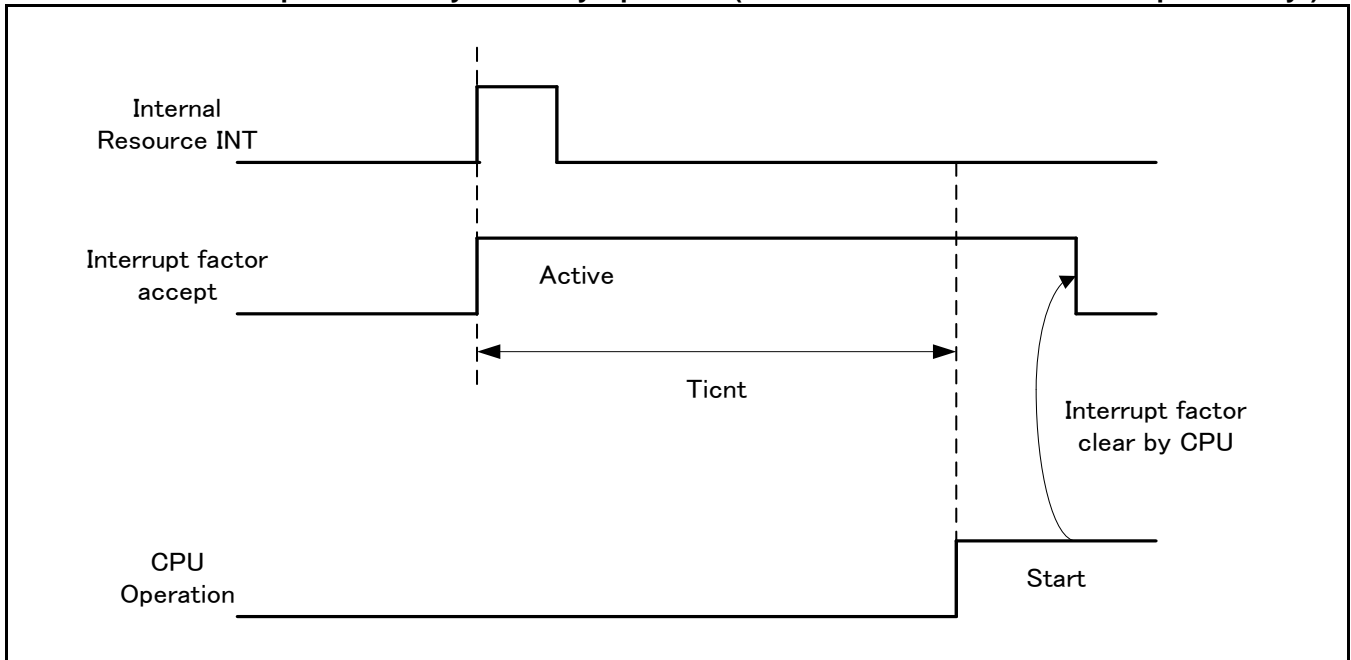

* : Depending on the standby mode, interrupt from the internal resource is not included in the recovery cause.

Notes:

- The return factor is different in each low-power consumption mode. See "Chapter 6: Low Power Consumption Mode" and "Operations of Standby Modes" in "FM4 Family Peripheral Manual Main Part (MN709-00001)."
- The recovery process is unique for each operating mode. See "Chapter 6: Low Power Consumption Mode" in "FM4 Family Peripheral Manual Main Part (MN709-00001)."

14.11.2 Recovery Cause: Reset

The time from reset release to the program operation start is shown.

Recovery Count Time

(V_{CC} = 2.7V to 5.5V, V_{SS} = 0V)

Parameter	Symbol	Value		Unit	Remarks
		Typ	Max*		
Sleep mode	Trcnt	155	266	μs	
High-speed CR timer mode		155	266	μs	
Main timer mode					
PLL timer mode					
Low-speed CR timer mode		315	567	μs	
Sub timer mode		315	567	μs	
RTC mode		315	567	μs	
Stop mode					
Deep standby RTC mode with RAM retention		336	667	μs	without RAM retention
Deep standby stop mode with RAM retention	336	667	μs	with RAM retention	

* : The maximum value depends on the built-in CR accuracy.

Example of Standby Recovery Operation (when in INITX recovery)

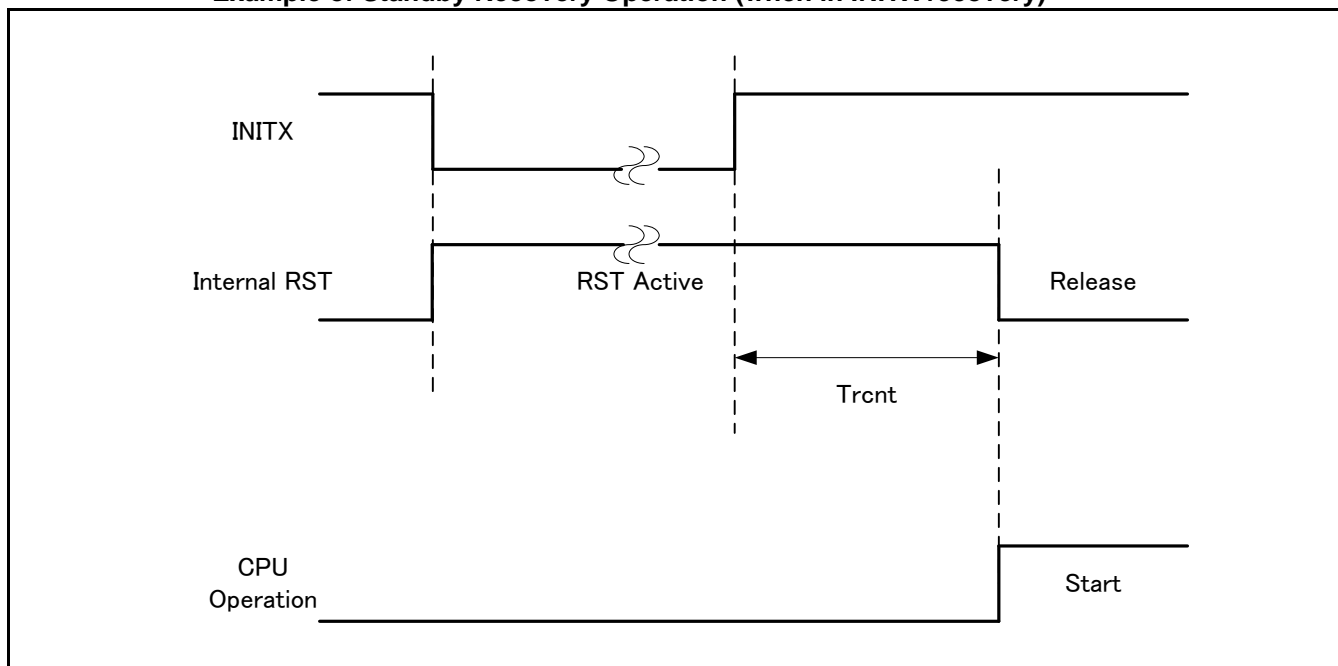

Example of Standby Recovery Operation (when in internal resource reset recovery*)

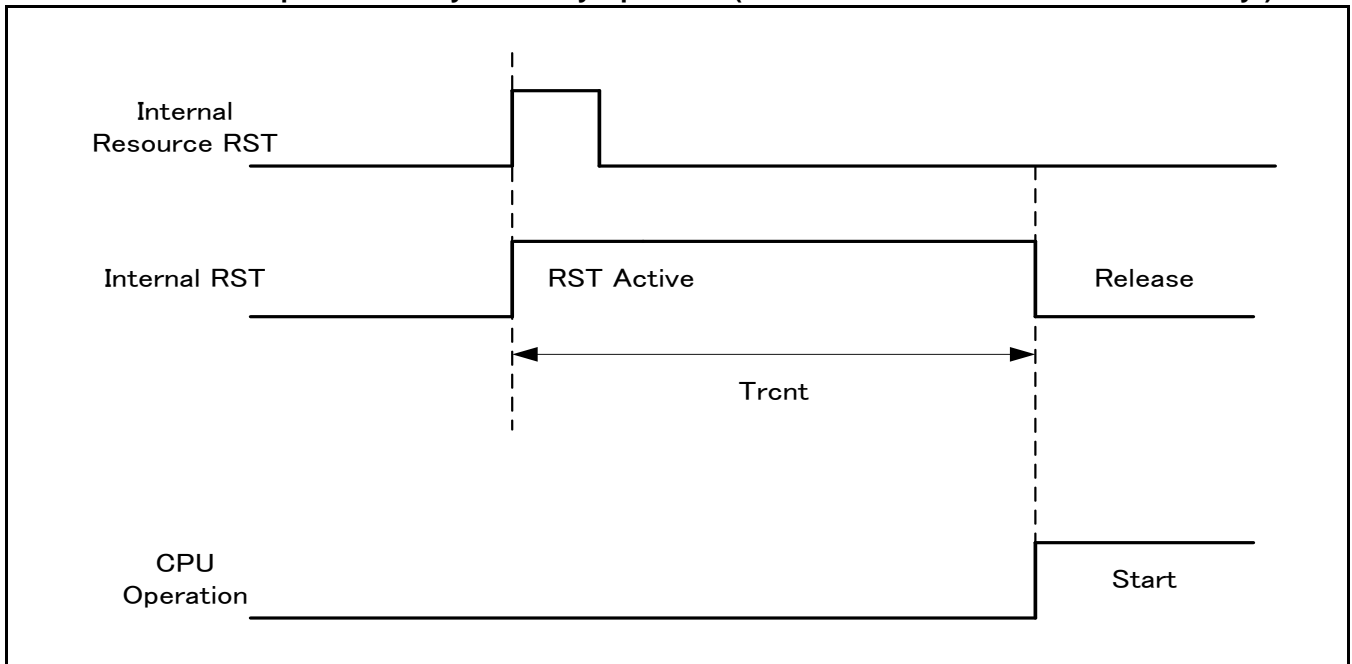

* : Depending on the low-power consumption mode, the reset issue from the internal resource is not included in the recovery cause.

Notes:

- The return factor is different in each low power consumption mode. See "Chapter 6: Low Power Consumption Mode" and "Operations of Standby Modes" in "FM4 Family Peripheral Manual Main Part (MN709-00001)."
- The recovery process is unique for each operating mode. See "Chapter 6: Low Power Consumption Mode" in "FM4 Family Peripheral Manual Main Part (MN709-00001)."
- When the power-on reset/low-voltage detection reset, they are not included in the return factor. See "14.4.8 Power-On Reset Timing."
- In recovering from reset, CPU changes to high-speed run mode. In the case of using the main clock and PLL clock, they need further main clock oscillation stabilization wait time and oscillation stabilization wait time of main PLL clock.
- Internal resource reset indicates Watchdog reset and CSV reset.

15. ORDERING INFORMATION

Part number	Package
S6E2C28H0AGV20000	Plastic · LQFP (0.5-mm pitch), 144 pin (FPT-144P-M08)
S6E2C29H0AGV20000	
S6E2C2AH0AGV20000	
S6E2C28J0AGV20000	Plastic · LQFP (0.65-mm pitch), 176 pin (FPT-176P-M07)
S6E2C29J0AGV20000	
S6E2C2AJ0AGV20000	
S6E2C28J0AGB10000	Plastic · LQFP (0.8-mm pitch), 192 pin (LBE192)
S6E2C29J0AGB10000	
S6E2C2AJ0AGB10000	
S6E2C28L0AGL20000	Plastic · LQFP (0.4-mm pitch), 216 pin (FPT-216P-M01)
S6E2C29L0AGL20000	
S6E2C2AL0AGL20000	

16. PACKAGE DIMENSIONS

<p>144-pin plastic LQFP</p> <p>(FPT-144P-M08)</p>	Lead pitch	0.50 mm
	Package width × package length	20.0 × 20.0 mm
	Lead shape	Gullwing
	Sealing method	Plastic mold
	Mounting height	1.70 mm MAX
	Weight	1.20 g
	Code (Reference)	P-LFQFP144-20×20-0.50

144-pin plastic LQFP
(FPT-144P-M08)

22.00±0.20(.866±.008)SQ
* 20.00±0.10(.787±.004)SQ

LEAD No. 1

INDEX

0.50(.020)

0.22±0.05
(.009±.002)

0.08(.003) M

Note 1) *: Values do not include resin protrusion.
Resin protrusion is +0.25(.010)Max(each side).

Note 2) Pins width and pins thickness include plating thickness.

Note 3) Pins width do not include tie bar cutting remainder.

0.145±0.055
(.006±.002)

0.08(.003)

Details of "A" part

1.50^{+0.20}/_{-0.10}
(.059^{+0.008}/_{-.004}) (Mounting height)

0°~8°

0.10±0.10
(.004±.004) (Stand off)

0.50±0.20
(.020±.008)

0.60±0.15
(.024±.006)

0.25(.010)

© 2003-2010 FUJITSU SEMICONDUCTOR LIMITED F144019S-c-4-8

Dimensions in mm (inches).
Note: The values in parentheses are reference values.

<p>176-pin plastic LQFP</p> <p>(FPT-176P-M07)</p>	Lead pitch	0.50 mm
	Package width × package length	24.0 × 24.0 mm
	Lead shape	Gullwing
	Sealing method	Plastic mold
	Mounting height	1.70 mm MAX
	Code (Reference)	P-LQFP-0176-2424-0.50

176-pin plastic LQFP
(FPT-176P-M07)

26.00±0.20(1.024±.008)SQ
*24.00±0.10(.945±.004)SQ

LEAD No. 1

0.50(.020) 0.22±0.05 (.009±.002) 0.08(.003) Ⓢ

Note 1) * : Values do not include resin protrusion.
Resin protrusion is +0.25(.010)Max(each side).

Note 2) Pins width and pins thickness include plating thickness

Note 3) Pins width do not include tie bar cutting remainder.

0.145±0.055 (.006±.002)

0.08(.003)

Details of "A" part

1.50^{+0.20}/_{-0.10} (Mounting height)
(.059^{+0.008}/_{-.004})

0.10±0.10 (.004±.004) (Stand off)

0°~8°

0.50±0.20 (.020±.008)

0.60±0.15 (.024±.006)

0.25(.010)

© 2004-2010 FUJITSU SEMICONDUCTOR LIMITED F176013S-c-1-3

Dimensions in mm (inches).
Note: The values in parentheses are reference values.

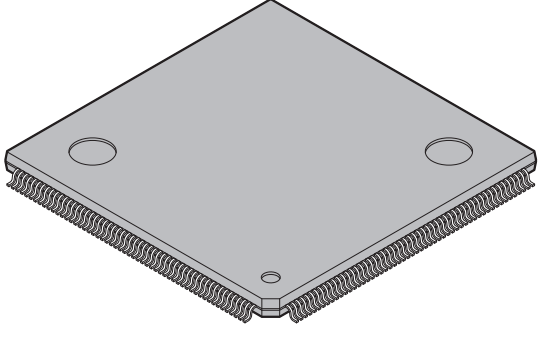
<p>216-pin plastic LQFP</p>  <p>(FPT-216P-M01)</p>	Lead pitch	0.40 mm
	Package width × package length	24.0 × 24.0 mm
	Lead shape	Gullwing
	Sealing method	Plastic mold
	Mounting height	1.70 mm MAX
	Code (Reference)	P-LFQFP216-24×24-0.40

216-pin plastic LQFP
(FPT-216P-M01)

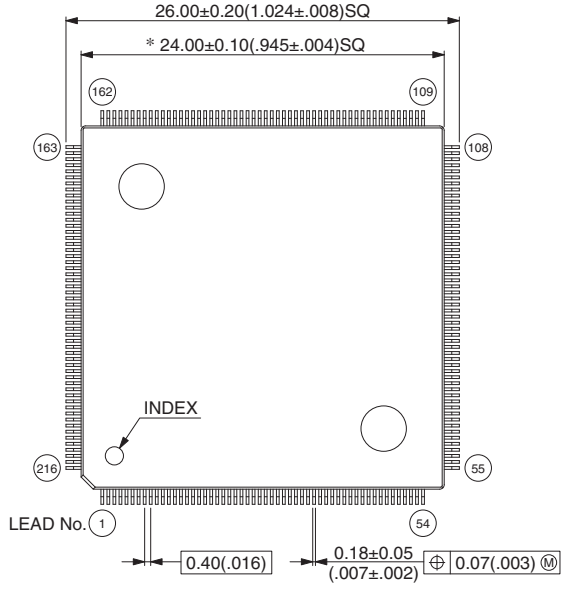

Note 1) * : These dimensions do not include resin protrusion.
 Note 2) Pins width and pins thickness include plating thickness.
 Note 3) Pins width do not include tie bar cutting remainder.

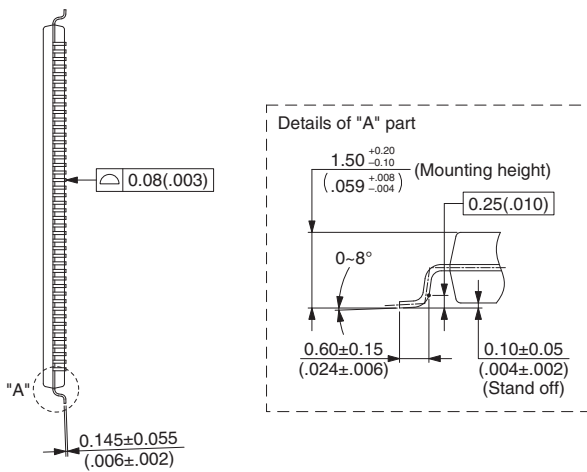

© 2003-2010 FUJITSU SEMICONDUCTOR LIMITED F216001S-c-2-4

Dimensions in mm (inches).
Note: The values in parentheses are reference values.

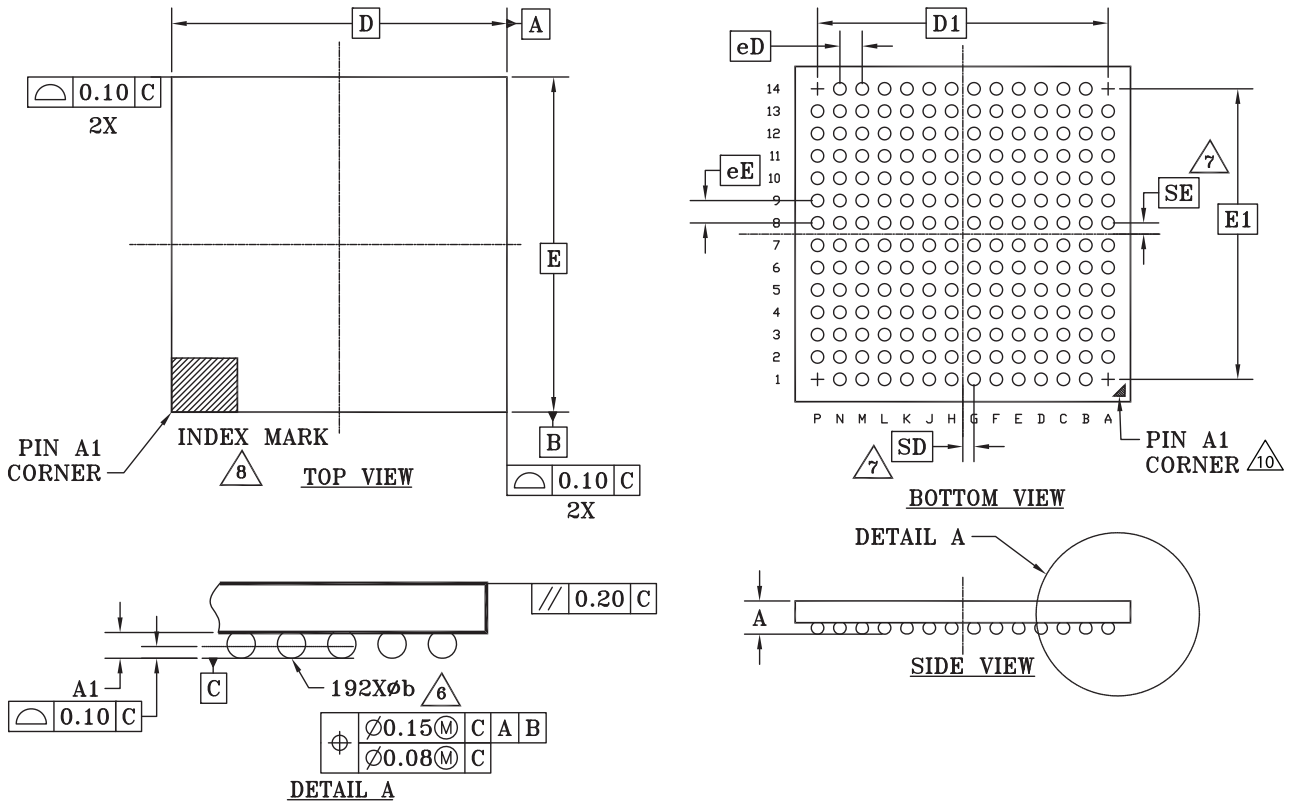

PACKAGE	LBE 192			NOTE
JEDEC	N/A			
D X E	12.00mm X 12.00mm PACKAGE			
SYMBOL	MIN.	NOM.	MAX.	
A	---	---	1.45	PROFILE
A1	0.25	---	---	BALL HEIGHT
D	12.00 BSC			BODY SIZE
E	12.00 BSC			BODY SIZE
D1	10.40 BSC			MATRIX FOOTPRINT
E1	10.40 BSC			MATRIX FOOTPRINT
MD	14			MATRIX SIZE D DIRECTION
ME	14			MATRIX SIZE E DIRECTION
n	192			BALL COUNT
Ø b	0.35	---	0.55	BALL DIAMETER
eE	0.80 BSC			BALL PITCH
eD	0.80 BSC			BALL PITCH
SD/SE	0.00 BSC			SOLDER BALL PLACEMENT
	A1, A14, P1, P14			DEPOPULATED SOLDER BALLS LOCATIONS

NOTES:

- DIMENSIONING AND TOLERANCING METHODS PER ASME Y14.5-2009. THIS OUTLINE CONFORMS TO JEP 95, SECTION 4.5.
- ALL DIMENSIONS ARE IN MILLIMETERS.
- BALL POSITION DESIGNATION PER JEP 95, SECTION 3, SPP-010.
- e REPRESENTS THE SOLDER BALL GRID PITCH.
- SYMBOL "MD" IS THE BALL MATRIX SIZE IN THE "D" DIRECTION. SYMBOL "ME" IS THE BALL MATRIX SIZE IN THE "E" DIRECTION. n IS THE NUMBER OF POPULATED SOLDER BALL POSITIONS FOR MATRIX SIZE MD X ME.
- DIMENSION "b" IS MEASURED AT THE MAXIMUM BALL DIAMETER IN A PLANE PARALLEL TO DATUM C.
- SD AND SE ARE MEASURED WITH RESPECT TO DATUMS A AND B AND DEFINE THE POSITION OF THE CENTER SOLDER BALL IN THE OUTER ROW. WHEN THERE IS AN ODD NUMBER OF SOLDER BALLS IN THE OUTER ROW SD OR SE = 0 WHEN THERE IS AN EVEN NUMBER OF SOLDER BALLS IN THE OUTER ROW SD OR SE = e/2
- A1 CORNER TO BE IDENTIFIED BY CHAMFER, LASER OR INK MARK, METALLIZED MARK INDENTATION OR OTHER MEANS.
- "+" INDICATES THE THEORETICAL CENTER OF DEPOPULATED BALLS.
- INDEX MARK IS OPTIONAL.

gs5036-1-lbe192 / 6.16.14

17. Major Changes

Page	Section	Change Results
Revision 0.1		
-	-	Initial release

Colophon

The products described in this document are designed, developed and manufactured as contemplated for general use, including without limitation, ordinary industrial use, general office use, personal use, and household use, but are not designed, developed and manufactured as contemplated (1) for any use that includes fatal risks or dangers that, unless extremely high safety is secured, could have a serious effect to the public, and could lead directly to death, personal injury, severe physical damage or other loss (i.e., nuclear reaction control in nuclear facility, aircraft flight control, air traffic control, mass transport control, medical life support system, missile launch control in weapons systems), or (2) for any use in which chance of failure is intolerable (i.e., submersible repeater and artificial satellite). Please note that Spansion will not be liable to you and/or any third party for any claims or damages arising in connection with above-mentioned uses of the products. Any semiconductor devices have an inherent chance of failure. You must protect against injury, damage or loss from such failures by incorporating safety design measures into your facility and equipment such as redundancy, fire protection, and prevention of over-current levels and other abnormal operating conditions. If any products described in this document represent goods or technologies subject to certain restrictions on export under the Foreign Exchange and Foreign Trade Law of Japan, the US Export Administration Regulations or the applicable laws of any other country, the prior authorization by the respective government entity will be required for export of those products.

Trademarks and Notice

The contents of this document are subject to change without notice. This document may contain information on a Spansion product under development by Spansion. Spansion reserves the right to change or discontinue work on any product without notice. The information in this document is provided as is without warranty or guarantee of any kind as to its accuracy, completeness, operability, fitness for particular purpose, merchantability, non-infringement of third-party rights, or any other warranty, express, implied, or statutory. Spansion assumes no liability for any damages of any kind arising out of the use of the information in this document.

Copyright © 2014 Spansion LLC. All rights reserved. Spansion®, the Spansion logo, MirrorBit®, MirrorBit® Eclipse™, ORNAND™, Easy DesignSim™, Traveo™ and combinations thereof, are trademarks and registered trademarks of Spansion LLC in the United States and other countries. Other names used are for informational purposes only and may be trademarks of their respective owners.